

# COPPERHEAD SERIES FIBRE CHANNEL TRANSCEIVER

## Line Interface Module

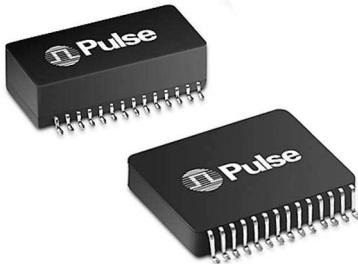

- ⊕ High Performance, low cost alternative to completely fiber systems
- ⊕ Compact small Package saves PCB foot print
- ⊕ Equalizer and transformers isolation provides long distance applications , better transient protection and common mode rejection.
- ⊕ Low transmit/receive jitter
- ⊕ Low Power dissipation; 300mW typical
- ⊕ Operating Temperature -55°C to +125°C

Transmitter		V <sub>cc</sub> = 3.15V to 3.45V			
Parameter	SYM	MIN	Typical	MAX	UNIT
Input Data Voltage Low	VIL	1.35	—	1.88	V
Input Data Voltage High	VIH	2.07	—	2.58	—
Differential Input Data Voltage	VIN	150	800	1200	mV P-P
Input High Voltage	—	—	—	—	—
Common Mode Range(Differential)	VIHCMR	2	—	3.3	V
Transmitte Output Impadence (Diff)	Ztx-Diff	100	150	—	Ohma
Output Differential signal level (p-p)	VOT	1100	1250	—	mV
Data Rate (NRZ)	DR	—	1062	—	Mb/s
Total P-P transmit jitter (Dj=Rj)	TPK-PK	—	180	235	ps
Output rise-fall time (20%-80%)	TRO	—	—	430	ps

Receiver		V <sub>cc</sub> = 3.15V to 3.45V			
Parameter	SYM	MIN	Typical	MAX	UNIT
Input Voltage swing(Differential)	VIN-P-P	150	—	1200	mV
Differential Output Data Voltage	VO-Diff.	500	—	1000	mV
OutputCommon-Mode Voltage	VO-comm	1.75	1.93	2.05	V
Data Rate (NRZ)	DR	—	1062	—	Mb/s
Total P-P transmit jitter (Dj=Rj)	TPK-PK	—	375	526	ps
Return Loss, Input	S11	-15	-17	—	dB

# COPPERHEAD SERIES FIBRE CHANNEL TRANSCEIVER

## Line Interface Module



### Mechanical

### Schematic

TM1062HSB1

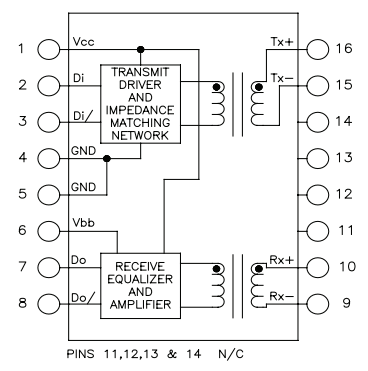
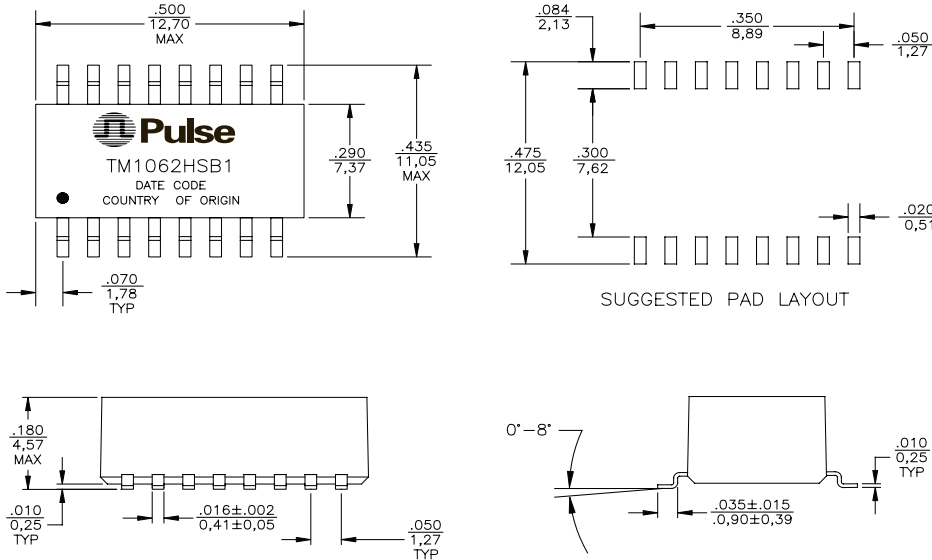

WEIGHT.....1.0 grams  
Tape & Reel.....400/reel  
Dimensions: Inches / mm  
Unless otherwise specified, all tolerances are ±.005 / 0.13

### Suggested Application For LVPECL Interface

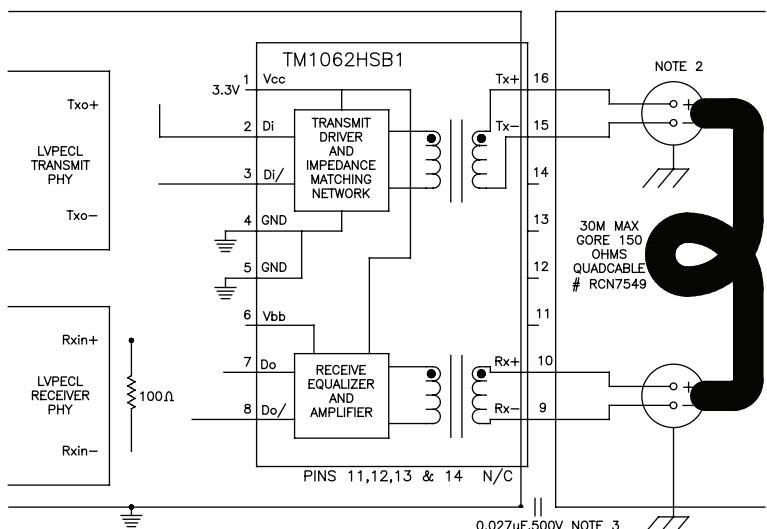

- NOTE 1.  
WHEN LAYING OUT PCB CABLE SIDE SIGNAL LINES SHALL BE 150 OHMS DIFFERENTIAL-CONTROL IMPEDANCE MICRO STRIP LINE TRACES AND PHY SIDE SIGNAL SHALL BE 100 OHMS DIFFERENTIAL CONTROL IMPEDANCE MICRO STRIP LINE TRACES.
- NOTE 2.  
CABLE CONNECTOR SHALL BE PLACED AS CLOSE AS POSSIBLE TO PULSE FIBRE CHANNEL TRANSCEIVER.
- NOTE 5.  
IT IS RECOMMENDED THAT SIGNAL GROUND FOR PHY SIDE AND CHASSIS GROUND FOR CABLE SIDE SHALL BE SEPERATE GROUND CABLE SHIELD BE CONNECTED TO CHASSIS GROUND. BOTH GROUNDS SHOULD BE AC COUPLED WITH 0.027μF, 500V CAPACITOR.

# SPLIT CORE Current Sense Transformers



## Suggested Application For LVDS and CML Interface

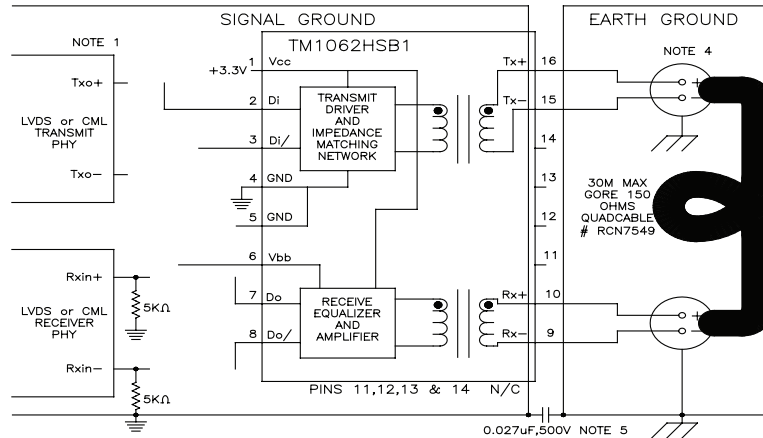

- NOTE 1.**  
FOR LVDS AND CML TRANSMIT INTERFACE AC COUPLE Di & Di/ LINE WITH 0.1 uF HI QUALITY CHIP CAPACITOR AND TERMINATE Di & Di/ (PINS 2 & 3) IN TO 50 OHMS TO Vbb (PIN 6) AS SHOWN ABOVE.
- NOTE 2.**  
FOR LVDS AND CML RECEIVE INTERFACE AC COUPLE Do & Do/ LINE WITH 0.1 uF HI QUALITY CHIP CAPACITOR AND TERMINATE Do & Do/ LINE AT LVDS RECEIVER INPUT PINS IN TO 50k OHMS TO GROUND TO BIAS THE COMMON-MODE VOLTAGE. CML RECEIVER DOES NOT REQUIRED ANY TERMINATION AS EACH INPUT HAS INTERVAL 50 OHMS TO Vcc TERMINATION (5K OHMS TERMINATION IS NOT REQUIRED FOR CML PHY).
- NOTE 3.**  
WHEN LAYING OUT PCB CABLE SIDE SIGNAL LINES SHALL BE 150 OHMS DIFFERENTIAL-CONTROL IMPEDANCE MICRO STRIP LINE TRACES AND PHY SIDE SIGNAL SHALL BE 100 OHMS DIFFERENTIAL CONTROL IMPEDANCE MICRO STRIP LINE TRACES.
- NOTE 4.**  
CABLE CONNECTOR SHALL BE PLACED AS CLOSE AS POSSIBLE TO PULSE FIBER CHANNEL TRANSCEIVER.
- NOTE 5.**  
IT IS RECOMMENDED THAT SIGNAL GROUND FOR PHY SIDE AND CHASSIS GROUND FOR CABLE SIDE SHALL BE SEPERATE GROUND CABLE SHIELD BE CONNECTED TO CHASSIS GROUND. BOTH GROUNDS SHOULD BE AC COUPLED WITH 0.027uF, 500V CAPACITOR.

Pin number(s)	Description
1.....	The positive supply for the line interface module. Connect to +3.3V for PECL application.
2, 3 .....	Di, Di/ : Differential PECL compatible data inputs to the transmitter side of the module. Di, Di/ should be control impedance 100 ohm differential line. If input to Di, Di/ is not PECL compatible Di/, Di should AC coupled with 0.1 uF close to pin 1 and pin 2 .and biased up to PECL common mode +2.0 V dc using 50 Ω to pin 1 and pin 2 ( 100 Ω differential).
4,5.....	Signal Gnd: The negative supply for the line interface module. Connect to Gnd for PECL applications.
6 .....	Vbb : Output ,PECL common mode voltage reference.
7,8 .....	DO , DO/ : Differential PECL data outputs. Terminate both output with 150 Ω to ground. Traces should be control impedance 100 ohm differential , can be terminated 100 ohms diff. at the receiver chip. If receiver is not PECL input Do and Do/ should be AC coupled with 0.1 uF close to pin 2 and 3 into 100 ohm differential line .Far end(at receiver chip) Do, Do/ should be terminated with 50 ohms to bias voltage Vbb. (this will terminate differential line into 100 ohm.)
9,10 .....	R X -, R X + : Transformer coupled differential inputs to receiver section Internally terminated for 150 Ω cable. For single ended coax applications, R X -should be connected to shield of cable/earth Gnd; R X + should be connected to the center conductor. Earth Gnd should be AC coupled to DC signal Gnd using a 0.027 μF capacitor, ~500V.
11,12,13,14....	No internal connection to these pins.
15, 16 .....	T X -, T X + : Transformer coupled differential outputs to 150Ω cable. For coax applications Tx-,should be connected to shield of cable/earth Gnd; T X + should be connected to the center conductor. Earth Gnd should be AC coupled to DC signal Gnd using a 0.027 μF capacitor, 500V.

### For More Information:

Pulse Worldwide Headquarters	Pulse Europe	Pulse China Headquarters	Pulse North China	Pulse South Asia	Pulse North Asia
Two Pearl Buck Court Bristol, PA 19007 U.S.A.	Zeppelinstrasse 15 D-71083 Herrenberg Germany	B402, Shenzhen Academy of Aerospace Technology Bldg. 10th Kejinan Rd. High-Tech Zone Nanshan District Shenzen, PR China 518057	Room 2704/2705 Super Ocean Finance Ctr. 2067 Yan An Rd. West Shanghai 200336 China	135 Joo Seng Rd. #03-02 PM Industrial Bldg. Singapore 368363	3F, No. 198 Zhongyuan Rd. Zhongli City Taoyuan County 320 Taiwan R. O. C. Tel: 886 3 4356768 Fax: 886 3 4356823 (Pulse) Fax: 886 3 4356820 (FRE)
<a href="http://www.pulseeng.com">www.pulseeng.com</a> Tel: 215 781 6400 Fax: 215 781 6403	Tel: 49 7032 7806 0 Fax: 49 7032 7806 135	Tel: 86 755 33966678 Fax: 86 755 33966700	Tel: 86 21 62787060 Fax: 86 2162786973	Tel: 65 6287 8998 Fax: 65 6287 8998	

Performance warranty of products offered on this data sheet is limited to the parameters specified. Data is subject to change without notice. Other brand and product names mentioned herein may be trademarks or registered trademarks of their respective owners. © Copyright, 2010. Pulse Engineering, Inc. All rights reserved.