





THT CURRENT SENSE TRANSFORMERS



-  UL/C-UL recognized components
-  3000Vrms gate to drive winding test
-  Useful operating frequency from 50kHz to 500kHz
-  Most popular winding configurations

Electrical Specifications @ 25°C — Operating Temperature -40°C to 130°C

Part ⁶ Number	Turns Ratio	Primary Inductance (1-10) (mH MIN)	DCR Pri (1-10) (Ω MAX)	DCR Sec1 (3-7) (mΩ ±15%)	DCR Sec2 (4-8) (mΩ ±15%)	Hi-Pot (Pri-Sec) (Vrms)
P0581	200:1:1	76	2.8	1.7	1.7	3000
P0582	100:1:1	19	1.4	1.7	1.7	3000
P0583	50:1:1	5	0.7	1.7	1.7	3000

Additional Specifications

Part Number	Reference Data			Calculation Data		
	RT	I _{pk} (Amps)	Drop (%)	Max Flux Density	K _b	Req (mΩ)
P0581	200	34	1.00	2000	17.12	.9
P0582	100	35	1.98	2000	68.49	.8
P0583	15	36	1.19	2000	273.97	.75

- NOTES:**
- These current sense transformers have two one turn primaries that can be used in parallel. The listed current ratings are for parallel connection.
 - The reference values are for an application using the termination resistor (R_t) and operating with unipolar waveform at 100kHz, 40% duty cycle. The estimated temperature rise is 55°C.
 - The peak flux density should remain below 2100 Gauss to ensure that the core does not saturate. Use the following formula to calculate the peak flux density: B_{pk} = K_b * I_{pk} * R_t * don / (F_f * Freq. in kHz) where: R_t is the terminating resistor in the application and F_f is 1 for unipolar waveform and 2 for bipolar waveform
 - To calculate the droop: Droop Exponent (D) = R_t * don / (L_{pri} in mH * Freq. in kHz) %Droop = (1 - e^{-D}) * 100
 - The temperature rise of the component is calculated based on the total core loss and copper loss:
 - To calculate total copper loss (W): P_(cu) = I_{pk}² * Req * F_f * don where: F_f is 1 for unipolar waveform and 2 for bipolar waveform
 - To calculate total core loss (W): P_(core) = 0.000073 * (Freq. in kHz)^{1.67} * (Bop in kG)^{2.532} where: Bop in kG = K_b * I_{pk} * R_t * don / (2000 * Freq. in kHz)
 - To calculate temperature rise: Temperature Rise (C) = 60.18 * (Core Loss(W) + Copper Loss (W))^{.833}
 - To order RoHS compliant part, add the suffix "NL" to the part number (i.e. P0581 becomes P0581NL).

Mechanical

Schematic

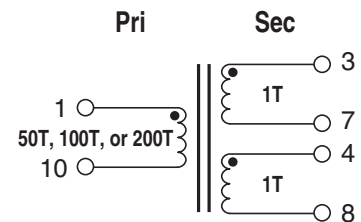
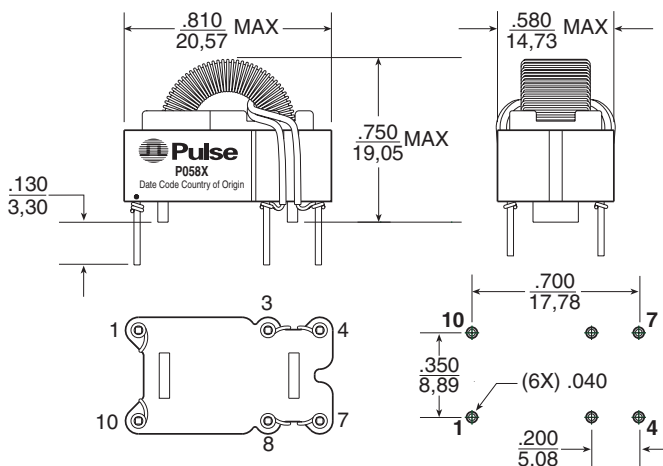

Weight5 grams
Tray20/tray

Dimensions: Inches
mm
Unless otherwise specified, all tolerances are ± .010 / 0.25

SUGGESTED PCB HOLE PATTERN

For More Information:

Pulse Worldwide Headquarters
12220 World Trade Dr.
San Diego, CA 92128
U.S.A.
www.pulseeng.com
TEL: 858 674 8100
FAX: 858 674 8262

Pulse Europe
Einsteinstrasse 1
D-71083 Herrenberg
Germany
Tel: 49 7032 7806 116
Fax: 49 7032 7806 135

Pulse China Headquarters
No. 1
Industrial District
Changan, Dongguan
China
Tel: 86 769 85538070
Fax: 86 769 85538870

Pulse North China
Room 1503
XinYin Building
No. 888 YiShan Rd.
Shanghai 200233
China
Tel: 86 21 54643211/2
Fax: 86 21 54643210

Pulse South Asia
150 Kampong Ampat
#07-01/02
KA Centre
Singapore 368324
Tel: 65 6287 8998
Fax: 65 6280 0080

Pulse North Asia
No. 26
Kao Ching Rd.
Yang Mei Chen
Taoyuan Hsien
Taiwan, R. O. C.
Tel: 886 3 4641811
Fax: 886 3 4641911

Performance warranty of products offered on this data sheet is limited to the parameters specified. Data is subject to change without notice. Other brand and product names mentioned herein may be trademarks or registered trademarks of their respective owners.

© Copyright, 2006. Pulse Engineering, Inc. All rights reserved.

www.pulseeng.com

P516.B (11/06)