

SMT POWER INDUCTORS

Unshielded Drum Core - PF0580NL Series



- Height:** 3.48mm Max
- Footprint:** 4.7mm Typ x 4.2mm Max
- Current Rating:** up to 3.1A
- Inductance Range:** 1μH to 65μH
- 260°C reflow peak temperature qualified**

Electrical Specifications @ 25°C — Operating Temperature -40°C to +125°C⁶

Part ⁵ Number	Inductance @Irated ¹ (μH TYP)	Irated ² (A)	DCR (mΩ MAX)	Inductance @0Adc (μH ±15%)	Saturation ³ Current Isat (A)	Heating ⁴ Current Idc (A)
PF0580.102NL	1.0	3.1	35	1.0	3.6	3.1
PF0580.152NL	1.4	2.7	40	1.5	2.7	2.7
PF0580.182NL	1.7	2.4	45	1.8	2.4	2.6
PF0580.222NL	2.1	2.2	49	2.2	2.2	2.4
PF0580.272NL	2.6	2.0	58	2.7	2.0	2.3
PF0580.332NL	3.1	1.8	63	3.3	1.8	2.25
PF0580.382NL	3.6	1.7	68	3.8	1.7	2.2
PF0580.472NL	4.5	1.6	77	4.7	1.6	2.0
PF0580.562NL	5.3	1.4	90	5.6	1.4	1.9
PF0580.682NL	6.5	1.3	100	6.8	1.3	1.8
PF0580.822NL	7.8	1.2	111	8.2	1.2	1.6
PF0580.103NL	9.5	1.1	132	10	1.1	1.5
PF0580.123NL	11	1.0	160	12	1.0	1.4
PF0580.153NL	14	0.85	197	15	0.85	1.3
PF0580.183NL	17	0.80	255	18	0.80	1.1
PF0580.223NL	21	0.75	280	22	0.75	1.0
PF0580.273NL	26	0.65	384	27	0.65	0.90
PF0580.333NL	31	0.58	427	33	0.58	0.85
PF0580.393NL	37	0.55	490	39	0.55	0.80
PF0580.473NL	45	0.50	645	47	0.50	0.70
PF0580.563NL	53	0.46	700	56	0.46	0.67
PF0580.683NL	65	0.41	827	68	0.41	0.62

Mechanical

Schematic

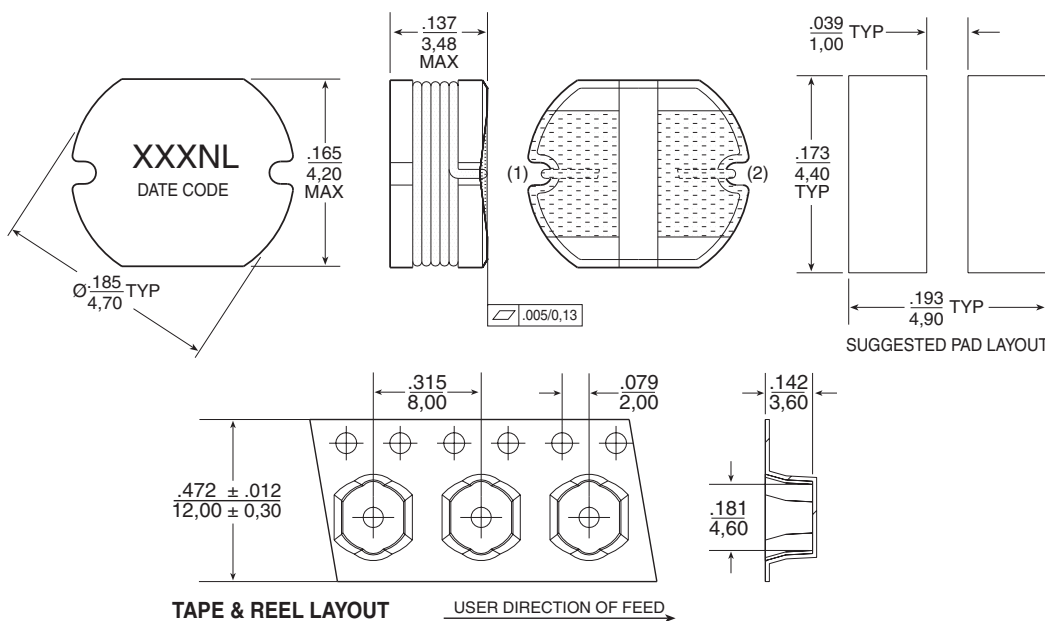

Weight0.22 grams
Tape & Reel1950/reel

Dimensions: Inches
mm
Unless otherwise specified,
all tolerances are ± .004
0,10

Notes from Tables

1. Inductance at I_{rated} is a typical inductance value for the component taken at rated current.
2. The rated current listed is the lower of the saturation current @ 25°C or the heating current.
3. The saturation current, I_{sat} , is the current at which the component inductance drops by 10% (maximum) at an ambient temperature of 25°C. This current is determined by placing the component in the specified ambient environment and applying a short duration pulse current (to eliminate self-heating effects) to the component.
4. The heating current, I_{hc} , is the DC current required to raise the component temperature by approximately 45°C. The heating current is determined by mounting the component on a typical PCB and applying current for 30 minutes.
5. Optional Tape & Reel packaging can be ordered by adding a "T" suffix to the part number (i.e. PF0580.102NL becomes PF0580.102NLT). Pulse complies to industry standard tape and reel specification EIA481.
6. The temperature of the component (ambient plus temperature rise) must be within the stated operating temperature range.

Typical Inductance vs Current Characteristics

