

SMT POWER INDUCTORS

Shielded Drum Core - PG0085NL Series



- Height:** 1.8mm Max
- Footprint:** 4.3mm x 4.3mm Max
- Current Rating:** up to 1.5A
- Inductance Range:** 0.7μH to 220μH

Electrical Specifications @ 25°C — Operating Temperature -40°C to +130°C¹

Part ^{2,3} Number	Inductance @0Adc (μH ±20%)	Inductance @Irated (μH TYP)	Irated ⁵ (A)	DCR (Ω)		Saturation ⁶ Current IsAT -40% (A)	Heating ⁷ Current Idc +40°C (A)	Core Loss ⁸ Factor (K2)	SRF (MHz)
				TYP	MAX				
PG0085.102NL	1.0	0.7	1.50	0.026	0.033	1.50	3.00	1300	>40
PG0085.152NL	1.5	1.0	1.30	0.033	0.038	1.30	2.60	1500	>40
PG0085.222NL	2.2	1.5	1.10	0.038	0.046	1.10	2.20	1900	>40
PG0085.332NL	3.3	2.3	1.00	0.060	0.077	1.00	2.00	2200	>40
PG0085.472NL	4.7	3.3	0.86	0.080	0.100	0.86	1.60	2800	>40
PG0085.682NL	6.8	4.8	0.66	0.093	0.115	0.66	1.30	3300	38
PG0085.103NL	10	7.0	0.55	0.152	0.182	0.55	1.10	3600	29
PG0085.153NL	15	10.5	0.45	0.207	0.235	0.45	0.90	4800	36
PG0085.223NL	22	15.4	0.40	0.330	0.360	0.40	0.80	5500	33
PG0085.333NL	33	23.1	0.30	0.463	0.510	0.30	0.60	7300	16
PG0085.473NL	47	32.9	0.28	0.655	0.780	0.28	0.55	8200	14
PG0085.683NL	68	47.6	0.26	0.930	1.200	0.26	0.50	10000	12
PG0085.104NL	100	70	0.18	1.450	1.750	0.18	0.35	12000	10
PG0085.154NL	150	105	0.16	1.780	2.000	0.16	0.30	15000	8.0
PG0085.224NL	220	154	0.13	2.800	3.500	0.13	0.26	18000	6.0

NOTES FROM TABLE: (See page 43)

Mechanical

Schematic

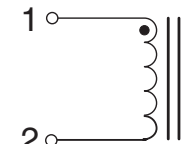
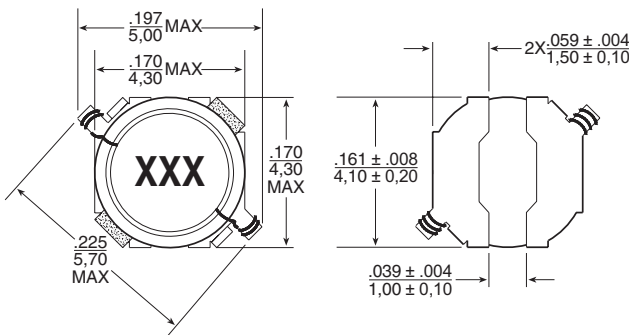

SUGGESTED PAD LAYOUT

Dimensions: Inches
mm
Unless otherwise specified,
all tolerances are ± .004
0,10

Weight 0.1 grams
Tape & Reel 2850/reel

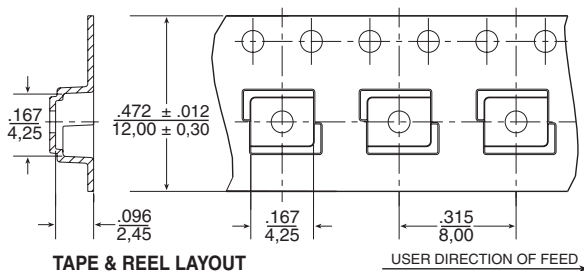

Inductance vs Current Characteristics

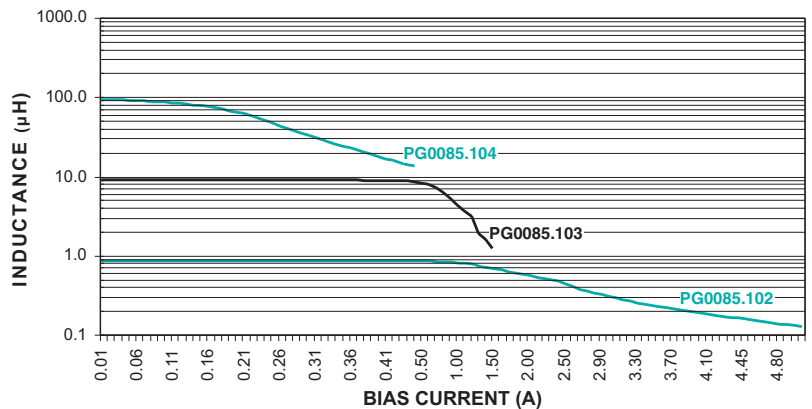

SMT POWER INDUCTORS

Shielded Drum Core Series



Notes from Tables (pages 27 - 42)

1. Unless otherwise specified, all testing is made at 100kHz, 0.1VAC.
2. Optional Tape & Reel packaging can be ordered by adding a "T" suffix to the part number (i.e. P1166.102NL becomes P1166.102NLT). Pulse complies with industry standard Tape and Tape & Reel specification EIA481.
3. The "NL" suffix indicates an RoHS-compliant part number. Non-NL suffixed parts are not necessarily RoHS compliant, but are electrically and mechanically equivalent to NL versions. If a part number does not have the "NL" suffix, but an RoHS compliant version is required, please contact Pulse for availability.
4. Temperature of the component (ambient plus temperature rise) must be within specified operating temperature range.
5. The rated current (I_{rated}) as listed is either the saturation current or the heating current depending on which value is lower.
6. The saturation current, I_{sat}, is the current at which the component inductance drops by the indicated percentage (typical) at an ambient temperature of 25°C. This current is determined by placing the component in the specified ambient environment and applying a short duration pulse current (to eliminate self-heating effects) to the component.
7. The heating current, I_{dc}, is the DC current required to raise the component temperature by the indicated delta (approximately). The heating current is determined by mounting the component on a typical PCB and applying current for 30 minutes. The temperature is measured by placing the thermocouple on top of the unit under test.

8. In high volt*time (Et) or ripple current applications, additional heating in the component can occur due to core losses in the inductor which may necessitate derating the current in order to limit the temperature rise of the component. In order to determine the approximate total loss (or temperature rise) for a given application, both copper losses and core losses should be taken into account.

Estimated Temperature Rise:

$$\text{Trise} = [\text{Total loss (mW)} / K0]^{.833} (\text{°C})$$

$$\text{Total loss} = \text{Copper loss} + \text{Core loss (mW)}$$

$$\text{Copper loss} = I_{\text{RMS}}^2 \times \text{DCR (Typical)} \text{ (mW)}$$

$$I_{\text{rms}} = [I_{\text{DC}}^2 + \Delta I^2/12]^{1/2} \text{ (A)}$$

$$\text{Core loss} = K1 \times f \text{ (kHz)}^{1.23} \times B_{\text{ac}}(\text{Ga})^{2.38} \text{ (mW)}$$

$$B_{\text{ac}} \text{ (peak to peak flux density)} = K2 \times \Delta I \text{ (Ga)}$$

$$[= K2/L(\mu\text{H}) \times Et(\text{V}\cdot\mu\text{Sec}) \text{ (Ga)}]$$

where f varies between 25kHz and 1MHz, and B_{ac} is less than 2500 Gauss.

K2 is a core size and winding dependant value and is given for each p/n in the proceeding datasheets. K0 & K1 are platform and material dependant constants and are given in the table below for each platform.

Part No.	Trise Factor (K0)	Core Loss Factor (K1)
PG0085	2.3	5.29E-10
PG0087	5.8	15.2E-10
PG0040/41	0.8	2.80E-10
P1174	0.8	6.47E-10
PF0601	4.6	14.0E-10
PF0464	3.6	24.7E-10
PF0465	3.6	33.4E-10
P1166	1.9	29.6E-10
P1167	2.1	42.2E-10
PF0560NL	5.5	136E-10
P1168/69	4.8	184E-10
P1170/71	4.3	201E-10
P1172/73	5.6	411E-10
PF0552NL	8.3	201E-10
PF0553NL	7.1	411E-10

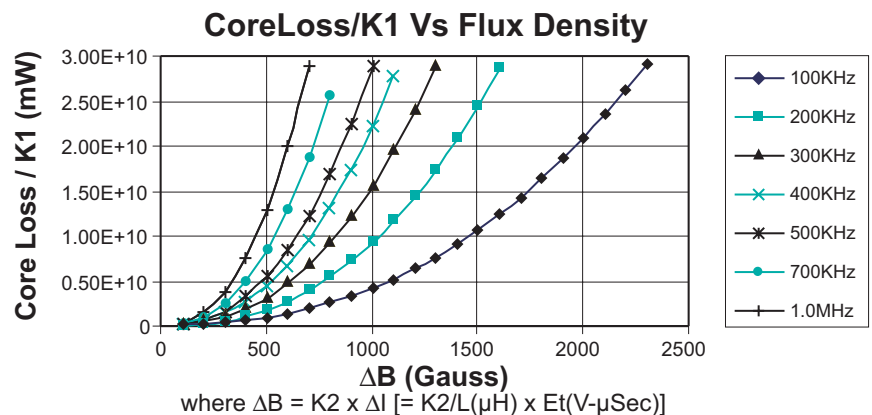

Take note that the component's temperature rise varies depending on the system condition. It is suggested that the component be tested at the system level, to verify the temperature rise of the component during system operation.