

**Description:**

Powerex Mega Power Dual (MPD) Modules are designed for use in switching applications. Each module consists of two IGBT Transistors having a reverse-connected super-fast recovery free-wheel diode. All components and interconnects are isolated from the heat sinking baseplate, offering simplified system assembly and thermal management.

**Features:**

- Low Drive Power
- Low  $V_{CE(sat)}$
- Discrete Super-Fast Recovery Free-Wheel Diode
- Isolated Baseplate for Easy Heatsinking
- RoHS Compliant

**Applications:**

- High Power DC Power Supply
- Large DC Motor Drives
- Utility Interface Inverters

**Ordering Information:**

Example: Select the complete module number you desire from the table - i.e. CM1400DUC-24S is a 1200V ( $V_{CES}$ ), 1400 Ampere Dual IGBTMOD Power Module.

Type	Current Rating Amperes	$V_{CES}$ Volts (x 50)
CM	1400	24

**Outline Drawing and Circuit Diagram**

Dimensions	Inches	Millimeters	Dimensions	Inches	Millimeters
A	5.91	150.0	M	0.075±0.008	1.9±0.2
B	5.10	129.5	N	0.47	12.0
C	1.67±0.01	42.5±0.25	P	0.26	6.5
D	5.41±0.01	137.5±0.25	R	M6 Metric	M6
E	6.54	166.0	S	0.08	2.0
F	2.91±0.01	74.0±0.25	T	0.99	25.1
G	1.65	42.0	U	0.62	15.7
H	0.55	14.0	V	0.71	18.0
J	1.50±0.01	38.0±0.25	W	0.75	19.0
K	0.16	4.0	X	0.43	11.0
L	1.36 +0.04/-0.02	34.6 +1.0/-0.5	Y	0.83	21.0
<b>Housing Type (J.S.T. MFG. CO. LTD)</b>			Z	0.41	10.5
BB = VHR-2N			AA	0.22	5.5
CC = VHR-5N					

**CM1400DUC-24S**  
**Mega Power Dual IGBT**  
 1400 Amperes/1200 Volts

**Absolute Maximum Ratings,  $T_j = 25^\circ\text{C}$  unless otherwise specified**

Characteristics	Symbol	Rating	Units
Collector-Emitter Voltage ( $V_{GE} = 0V$ )	$V_{CES}$	1200	Volts
Gate-Emitter Voltage ( $V_{CE} = 0V$ )	$V_{GES}$	$\pm 20$	Volts
Collector Current (DC, $T_C = 124^\circ\text{C}$ ) <sup>*2,*4</sup>	$I_C$	1400	Amperes
Collector Current (Pulse, Repetitive) <sup>*3</sup>	$I_{CRM}$	2800	Amperes
Total Power Dissipation ( $T_C = 25^\circ\text{C}$ ) <sup>*2,*4</sup>	$P_{tot}$	9370	Watts
Emitter Current <sup>*2</sup>	$I_E^{*1}$	1400	Amperes
Emitter Current (Pulse, Repetitive) <sup>*3</sup>	$I_{ERM}^{*1}$	2800	Amperes
Isolation Voltage (Terminals to Baseplate, RMS, $f = 60\text{Hz}$ , AC 1 minute)	$V_{isol}$	4000	Volts
Maximum Junction Temperature	$T_{j(max)}$	175	$^\circ\text{C}$
Maximum Case Temperature <sup>*4</sup>	$T_C (max)$	125	$^\circ\text{C}$
Operating Junction Temperature	$T_{j(op)}$	-40 to +150	$^\circ\text{C}$
Storage Temperature	$T_{stg}$	-40 to +125	$^\circ\text{C}$

\*1 Represent ratings and characteristics of the anti-parallel, emitter-to-collector clamp diode.

\*2 Junction temperature ( $T_j$ ) should not increase beyond maximum junction temperature ( $T_{j(max)}$ ) rating.

\*3 Pulse width and repetition rate should be such that device junction temperature ( $T_j$ ) does not exceed  $T_{j(max)}$  rating.

\*4 Case temperature ( $T_C$ ) and heatsink temperature ( $T_s$ ) is measured on the surface (mounting side) of the baseplate and the heatsink side just under the chips. Refer to the figure to the right for chip location.

The heatsink thermal resistance should be measured just under the chips.

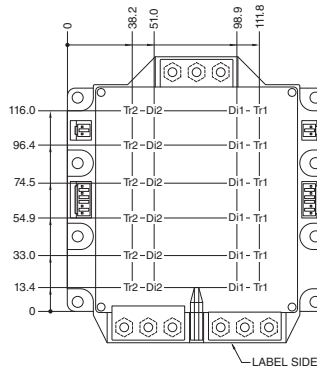

Tr1, Tr2: IGBT, Di1, Di2: FWD  
 Each mark points to the center position of each chip.

**CM1400DUC-24S**  
**Mega Power Dual IGBT**  
 1400 Amperes/1200 Volts

**Electrical Characteristics,  $T_j = 25^\circ\text{C}$  unless otherwise specified**

Characteristics	Symbol	Test Conditions	Min.	Typ.	Max.	Units
Collector-Emitter Cutoff Current	$I_{CES}$	$V_{CE} = V_{CES}, V_{GE} = 0V$	—	—	1	mA
Gate-Emitter Leakage Current	$I_{GES}$	$V_{GE} = V_{GES}, V_{CE} = 0V$	—	—	3.0	$\mu\text{A}$
Gate-Emitter Threshold Voltage	$V_{GE(th)}$	$I_C = 140\text{mA}, V_{CE} = 10V$	5.4	6.0	6.6	Volts
Collector-Emitter Saturation Voltage (Terminal)	$V_{CE(sat)}$	$I_C = 1400A, V_{GE} = 15V, T_j = 25^\circ\text{C}^{*6}$	—	1.55	1.90	Volts
		$I_C = 1400A, V_{GE} = 15V, T_j = 125^\circ\text{C}^{*6}$	—	1.75	—	Volts
		$I_C = 1400A, V_{GE} = 15V, T_j = 150^\circ\text{C}^{*6}$	—	1.80	—	Volts
Collector-Emitter Saturation Voltage (Chip)	$V_{CE(sat)}$	$I_C = 1400A, V_{GE} = 15V, T_j = 25^\circ\text{C}^{*6}$	—	1.55	1.90	Volts
		$I_C = 1400A, V_{GE} = 15V, T_j = 125^\circ\text{C}^{*6}$	—	1.75	—	Volts
		$I_C = 1400A, V_{GE} = 15V, T_j = 150^\circ\text{C}^{*6}$	—	1.80	—	Volts
Input Capacitance	$C_{ies}$		—	—	150	nF
Output Capacitance	$C_{oes}$	$V_{CE} = 10V, V_{GE} = 0V$	—	—	30	nF
Reverse Transfer Capacitance	$C_{res}$		—	—	2.5	nF
Gate Charge	$Q_G$	$V_{CC} = 600V, I_C = 1400A, V_{GE} = 15V$	—	3500	—	nC
Turn-on Delay Time	$t_{d(on)}$		—	—	900	ns
Rise Time	$t_r$	$V_{CC} = 600V, I_C = 1400A, V_{GE} = \pm 15V,$	—	—	250	ns
Turn-off Delay Time	$t_{d(off)}$	$R_G = 0\Omega, \text{Inductive Load}$	—	—	950	ns
Fall Time	$t_f$		—	—	350	ns
Emitter-Collector Voltage (Terminal)	$V_{EC}^{*1}$	$I_E = 1400A, V_{GE} = 0V, T_j = 25^\circ\text{C}^{*6}$	—	1.65	2.10	Volts
		$I_E = 1400A, V_{GE} = 0V, T_j = 125^\circ\text{C}^{*6}$	—	1.65	—	Volts
		$I_E = 1400A, V_{GE} = 0V, T_j = 150^\circ\text{C}^{*6}$	—	1.65	—	Volts
Emitter-Collector Voltage (Chip)	$V_{EC}^{*1}$	$I_E = 1400A, V_{GE} = 0V, T_j = 25^\circ\text{C}^{*6}$	—	1.65	2.10	Volts
		$I_E = 1400A, V_{GE} = 0V, T_j = 125^\circ\text{C}^{*6}$	—	1.65	—	Volts
		$I_E = 1400A, V_{GE} = 0V, T_j = 150^\circ\text{C}^{*6}$	—	1.65	—	Volts
Reverse Recovery Time	$t_{rr}^{*1}$	$V_{CC} = 600V, I_E = 1400A, V_{GE} = \pm 15V$	—	—	450	ns
Reverse Recovery Charge	$Q_{rr}^{*1}$	$R_G = 0\Omega, \text{Inductive Load}$	—	90	—	$\mu\text{C}$
Turn-on Switching Energy per Pulse	$E_{on}$	$V_{CC} = 600V, I_C = I_E = 1400A,$	—	82.2	—	mJ
Turn-off Switching Energy per Pulse	$E_{off}$	$V_{GE} = \pm 15V, R_G = 0\Omega, T_j = 150^\circ\text{C},$	—	260	—	mJ
Reverse Recovery Energy per Pulse	$E_{rr}^{*1}$	Inductive Load	—	122	—	mJ
Internal Lead Resistance	$R_{CC}^{*4} + EE^{*4}$	Main Terminals-Chip, Per Switch, $T_C = 25^\circ\text{C}^{*4}$	—	0.286	—	m $\Omega$
Internal Gate Resistance	$r_g$	Per Switch	—	1.7	—	$\Omega$

\*1 Represent ratings and characteristics of the anti-parallel, emitter-to-collector clamp diode.

\*4 Case temperature ( $T_C$ ) and heatsink temperature ( $T_S$ ) is measured on the surface (mounting side) of the baseplate and the heatsink side just under the chips. Refer to the figure to the right for chip location. The heatsink thermal resistance should be measured just under the chips.

\*6 Pulse width and repetition rate should be such as to cause negligible temperature rise.

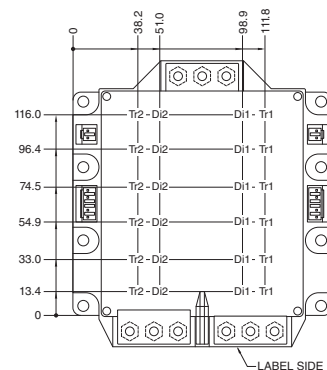

Tr1, Tr2: IGBT, D1, D2: FWDI  
 Each mark points to the center position of each chip.

**CM1400DUC-24S**  
**Mega Power Dual IGBT**  
 1400 Amperes/1200 Volts

## Electrical Characteristics, $T_j = 25^\circ\text{C}$ unless otherwise specified (continued)

### Thermal Resistance Characteristics

Thermal Resistance, Junction to Case <sup>*4</sup>	$R_{th(j-c)Q}$	Per Inverter IGBT	—	—	16	K/kW
Thermal Resistance, Junction to Case <sup>*4</sup>	$R_{th(j-c)D}$	Per Inverter Diode	—	—	26	K/kW
Contact Thermal Resistance,	$R_{th(c-f)}$	Thermal Grease Applied	—	6	—	K/kW
	Case to Heatsink	(Per 1 Module) <sup>*7</sup>				

### Mechanical Characteristics

Mounting Torque	$M_t$	Main Terminals, M6 Screw	22	27	31	in-lb
	$M_s$	Mounting to Heatsink, M6 Screw	22	27	31	in-lb
Creepage Distance	$d_s$	Terminal to Terminal	24	—	—	mm
		Terminal to Baseplate	33	—	—	mm
Clearance	$d_a$	Terminal to Terminal	14	—	—	mm
		Terminal to Baseplate	33	—	—	mm
Weight	$m$		—	1450	—	Grams
Flatness of Baseplate	$e_c$	On Centerline X, Y <sup>*5</sup>	-50	—	+100	$\mu\text{m}$

### Recommended Operating Conditions, $T_a = 25^\circ\text{C}$

(DC) Supply Voltage	$V_{CC}$	Applied Across P-N	—	600	850	Volts
Gate-Emitter Drive Voltage	$V_{GE(on)}$	Applied Across G-Es	13.5	15.0	16.5	Volts
External Gate Resistance	$R_G$	Per Switch	0	—	2.2	$\Omega$

<sup>\*4</sup> Case temperature ( $T_C$ ) and heatsink temperature ( $T_S$ ) is measured on the surface (mounting side) of the baseplate and the heatsink side just under the chips. Refer to the figure to the right for chip location.

The heatsink thermal resistance should be measured just under the chips.

<sup>\*5</sup> Baseplate (mounting side) flatness measurement points (X, Y) are shown in the figure below.

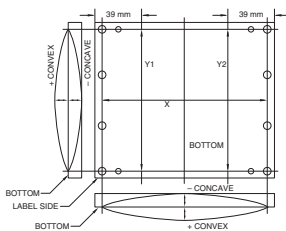

<sup>\*7</sup> Typical value is measured by using thermally conductive grease of  $\lambda = 0.9$  [W/(m • K)].

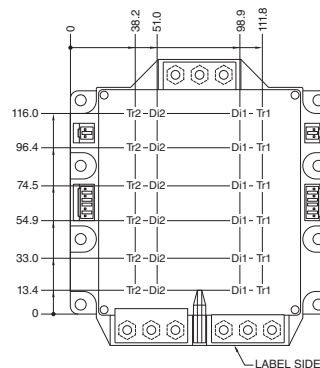

Tr1, Tr2: IGBT, D1, D2: FWD  
 Each mark points to the center position of each chip.

**CM1400DUC-24S**  
**Mega Power Dual IGBT**  
 1400 Amperes/1200 Volts

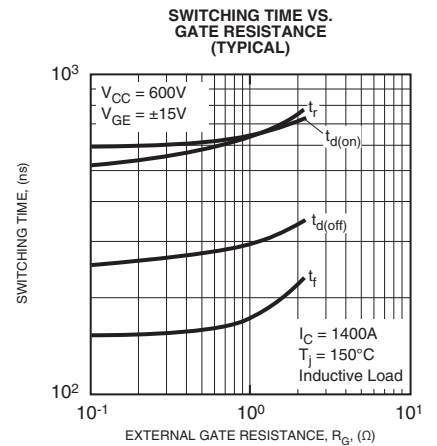
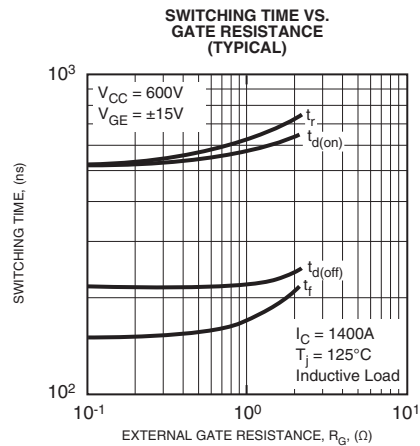
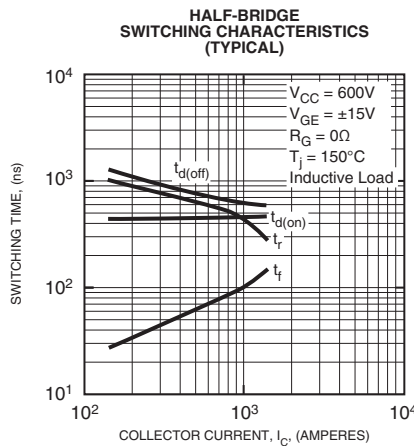
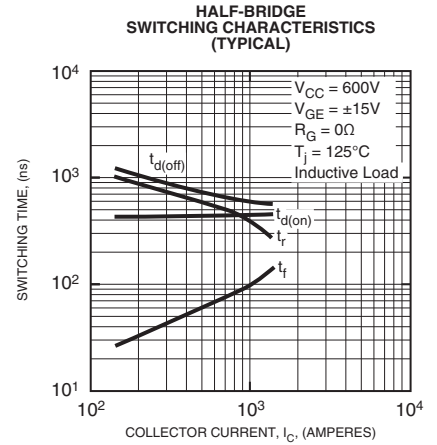
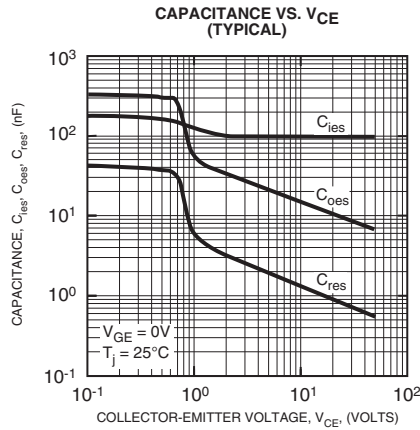
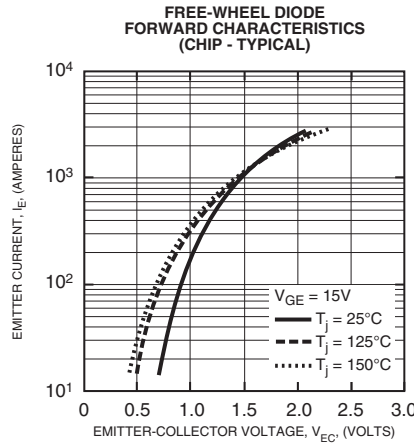
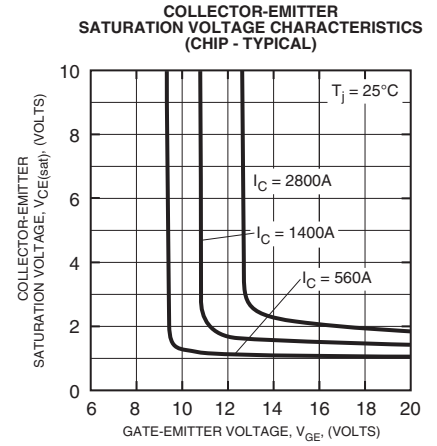
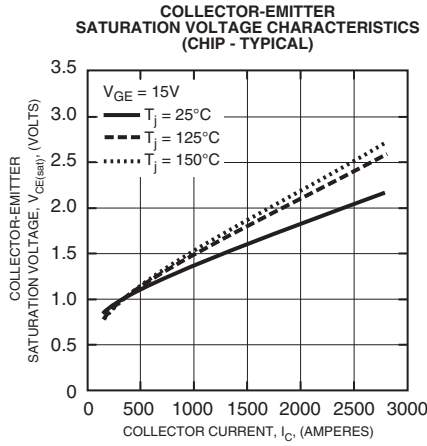
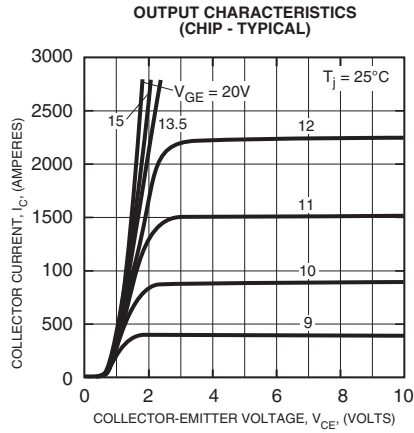

**CM1400DUC-24S**  
**Mega Power Dual IGBT**  
 1400 Amperes/1200 Volts

**REVERSE RECOVERY CHARACTERISTICS (TYPICAL)**

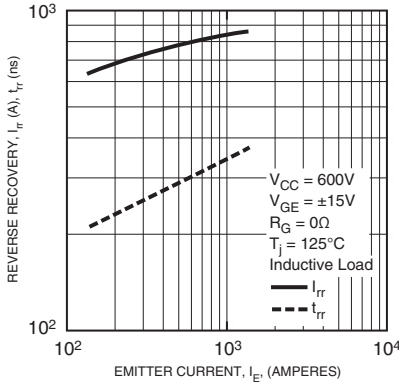

**REVERSE RECOVERY CHARACTERISTICS (TYPICAL)**

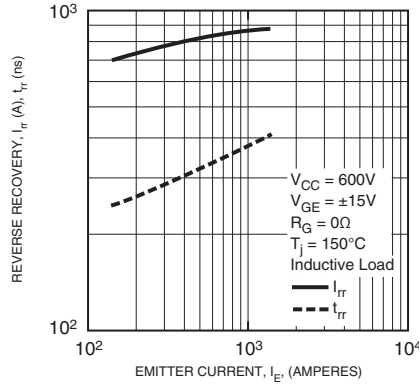

**GATE CHARGE VS. V\_GE**

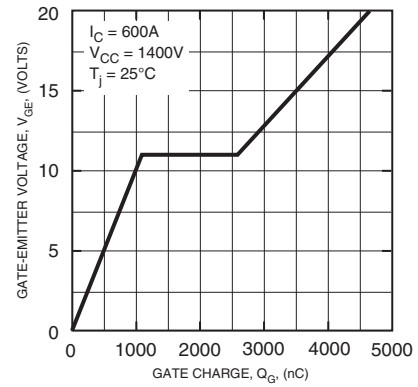

**HALF-BRIDGE SWITCHING CHARACTERISTICS (TYPICAL)**

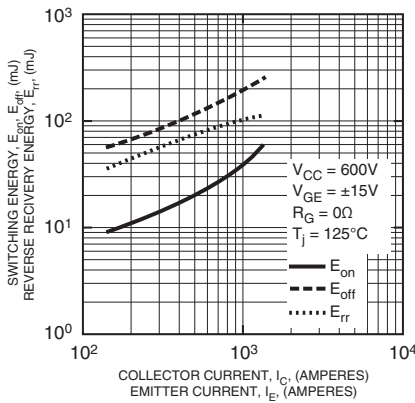

**HALF-BRIDGE SWITCHING CHARACTERISTICS (TYPICAL)**

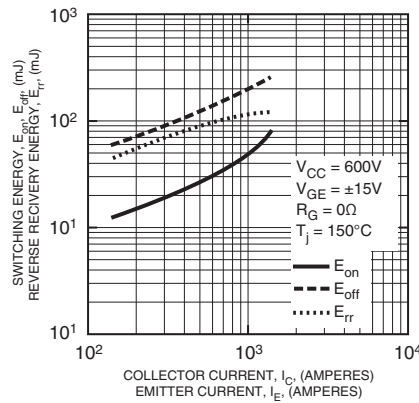

**HALF-BRIDGE SWITCHING CHARACTERISTICS (TYPICAL)**

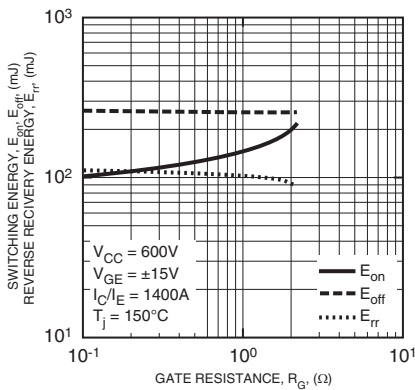
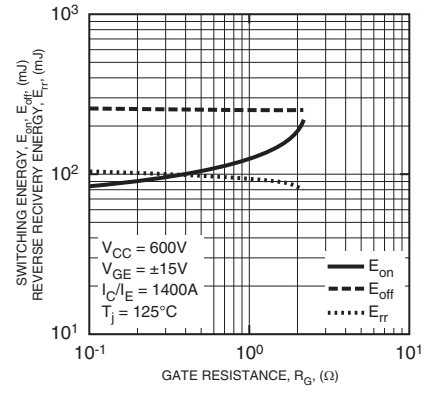

**TRANSIENT THERMAL IMPEDANCE CHARACTERISTICS (MAXIMUM)**

