

Intellimod™ Module Dual-In-Line Intelligent Power Factor Correction Module 20 Amperes/600 Volts

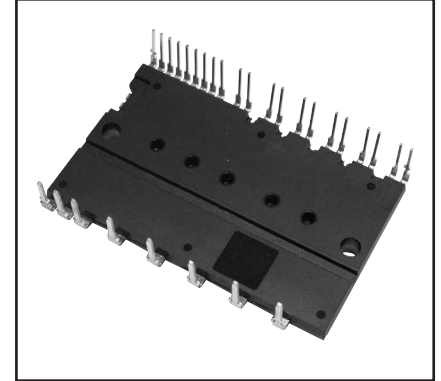
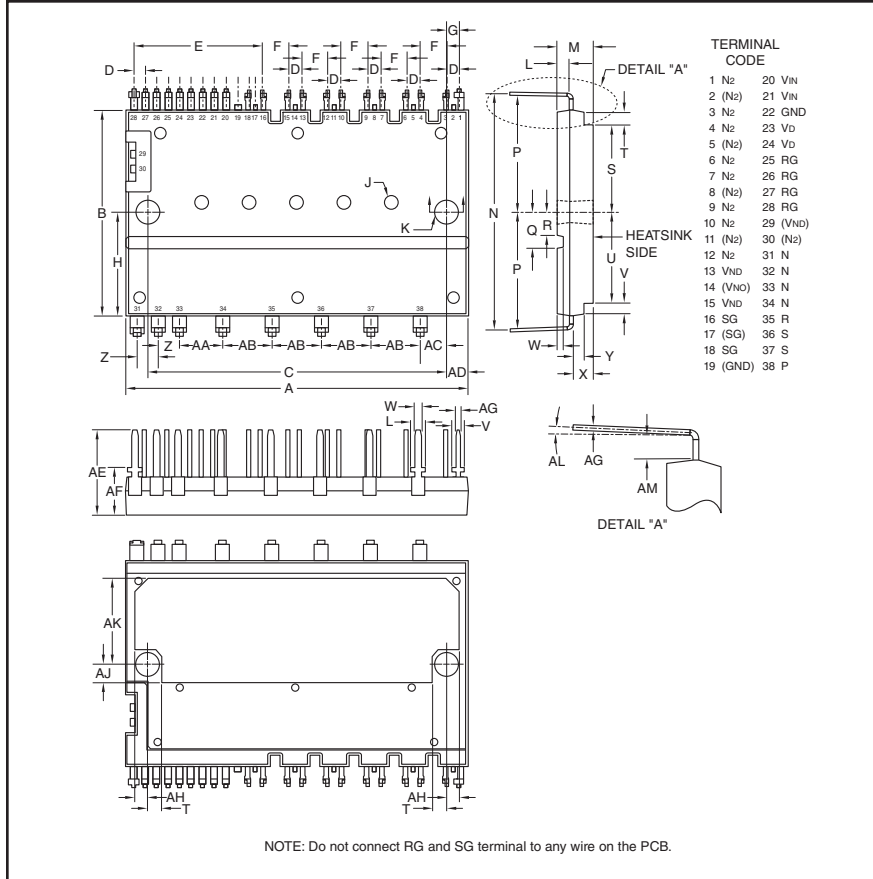

Description:

DIPPFCT™ is an intelligent power factor correction module that integrates power devices, drivers and protection circuitry in an ultra-compact dual-in-line package. Design time is reduced by the use of application-specific HVIC and a bridge-less topology. Overall efficiency and reliability are increased by use of CSTBT technology and low thermal impedance.

Features:

- Low-loss CSTBT IGBTs
- Single Power Supply
- Efficient bridge-less Topology
- Integrated HVIC

Applications:

- HVAC
- Compressors
- Pumps

Ordering Information:

PS51787 is a 600V, 20 A_{RMS} DIPPFCT™ Module.

Outline Drawing and Circuit Diagram

Dimensions	Inches	Millimeters
A	2.07	52.5
B	1.22	31.0
C	1.81±0.008	46.0±0.2
D	0.07±0.008	1.78±0.2
E	0.77	19.58
F	0.17±0.008	4.32±0.2
G	0.08±0.019	2.04±0.3
H	0.61	15.5
J	0.09 Dia. x 0.1 Depth	2.2 Dia. x 2.6 Depth
K	0.13 Dia.	3.3 Dia.
L	0.08	2.0
M	0.22	5.6
N	1.41±0.02	35.9±0.5
P	0.69	17.7
Q	0.216	5.5
R	0.14	3.5
S	0.503	12.78
T	0.09	2.2

Dimensions	Inches	Millimeters
U	0.53	13.5
V	0.06	1.5
W	0.04	1.0
X	0.12	3.1±0.1
Y	0.06	1.55
Z	0.13±0.019	3.3±0.3
AA	0.26±0.019	6.6±0.3
AB	0.3±0.019	7.62±0.3
AC	0.15±0.019	3.95±0.3
AD	0.13	3.25
AE	0.5	12.7
AF	0.28	7.1
AG	0.02	0.5
AH	0.067	1.7
AJ	0.11	2.8
AK	0.51	13.0
AL	0° ~ 5°	
AM	0.078	1.96

PS51787
Intellimod™ Module
Dual-In-Line Intelligent Power Factor Correction Module
 20 Amperes/600 Volts

Absolute Maximum Ratings, $T_j = 25^\circ\text{C}$ unless otherwise specified

Characteristics	Symbol	PS51787	Units
Input Supply Voltage (Between S-R Terminals)	V_i	264	V_{rms}
Input Supply Voltage, Surge (Between S-R Terminals)	$V_{i(surge)}$	500	Volts
Output Voltage (Between P-N Terminals)	V_O	450	Volts
Output Voltage, Surge (Between P-N Terminals)	$V_{O(surge)}$	500	Volts
Collector-Emitter Voltage	V_{CES}	600	Volts
Repetative Peak Reverse Voltage	V_{RRM}	600	Volts
Input Current, 100% Load ($T_C \leq 100^\circ\text{C}$, $V_i = 220V_{rms}$, $V_O = 390V$, $f_{PWM} = 20\text{kHz}$)	I_i	20	A_{rms}
Input Current, 125% Load ($T_C \leq 100^\circ\text{C}$, $V_i = 220V_{rms}$, $V_O = 390V$, $f_{PWM} = 20\text{kHz}$, Non-repetative, within 1 Minute)	$I_{i(125\%)}$	25	A_{rms}
I^2t for Fusing (Value for 1 Cycle of Surge Current, $t_w = 8.3\text{ms}$, Non-repetitive)	I^2t	120	A^2s
Junction Temperature*	T_j	-20 to 150	$^\circ\text{C}$
Module Case Operation Temperature**	T_C	-20 to 100	$^\circ\text{C}$
Storage Temperature	T_{stg}	-40 to 125	$^\circ\text{C}$
Mounting Torque, M3 Mounting Screws	—	8.7	in-lb
Module Weight (Typical)	—	21	Grams
Isolation Voltage, AC 1 minute, 60Hz Sinusoidal, Connection Pins to Heatsink Plate	V_{ISO}	2500	V_{rms}

Control Sector

Control Supply Voltage (Applied between V_D -GND)	V_D	20	Volts
Input Voltage (Applied between V_{IN} -GND)	V_{IN}	$0 \sim V_D + 0.5$	Volts

*The maximum junction temperature rating of the power chips integrated within the DIPFPC is 150°C ($@T_C \leq 100^\circ\text{C}$). However, to ensure safe operation of the DIPFPC, the average junction temperature should be limited to $T_{j(avg)} \leq 125^\circ\text{C}$ ($@T_C \leq 100^\circ\text{C}$).

**** T_C Measurement Point**

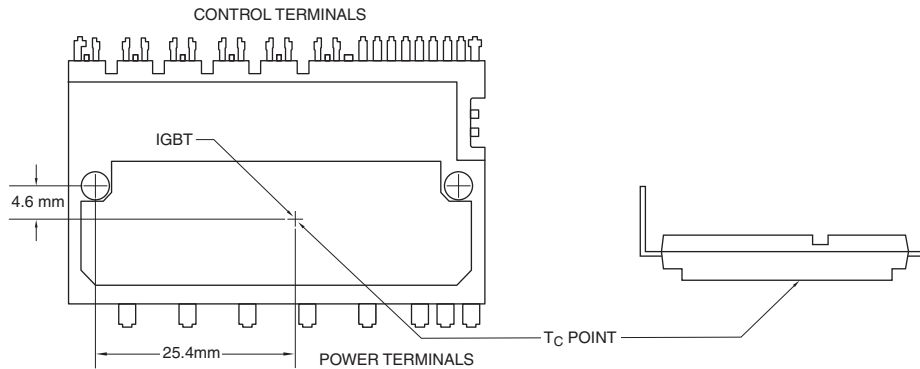

PS51787

Intellimod™ Module

Dual-In-Line Intelligent Power Factor Correction Module

20 Amperes/600 Volts

Electrical and Mechanical Characteristics, $T_j = 25^\circ\text{C}$ unless otherwise specified

Characteristics	Symbol	Test Conditions	Min.	Typ.	Max.	Units
Collector-Emitter Saturation Voltage	$V_{CE(sat)}$	$V_D = 15V, V_{IN} = 5V, I_C = 30A$	—	1.9	2.5	Volts
H-Diode Forward Voltage*	$V_{F(H)}$	$I_F = 30A$, Applied Between R-P, S-P	—	1.9	2.5	Volts
L-Diode Forward Voltage*	$V_{F(L)}$	$I_F = 30A$, Applied Between N2-R, N2-S	—	1.0	1.3	Volts
Switching Times	t_{on}		—	0.25	0.35	μs
	$t_{C(on)}$	$V_{CC} = 300V, V_D = 15V,$	—	0.14	0.23	μs
	t_{off}	$I_C = 30A, T_j = 125^\circ\text{C},$	—	0.40	0.65	μs
	$t_{C(off)}$	Inductive Load, $V_{IN} = 0 \leftrightarrow 5V$	—	0.18	0.35	μs
	t_{rr}		—	0.11	—	μs
Collector-Emitter Cutoff Current	I_{CES}	$V_{CE} = 600V, T_j = 25^\circ\text{C}$	—	—	1.0	mA
		$V_{CE} = 600V, T_j = 125^\circ\text{C}$	—	—	10	mA
Reverse Current	I_R	$V_R = 600V, T_j = 25^\circ\text{C}$	—	—	1.0	mA
		$V_R = 600V, T_j = 125^\circ\text{C}$	—	—	10	mA
Diode Recovery Current	I_{rr}	$V_{CC} = 300V, V_D = 15V, I_C = 30A$	—	11	—	Amperes

Control Sector

Circuit Current	I_D	Applied Between V_D -GND, $V_D = 15V, V_{IN} = 5V$	—	0.8	3.0	mA
		Applied Between V_D -GND, $V_D = 15V, V_{IN} = 0V$	—	0.7	3.0	mA
Input Current	I_{IN}	$V_D = 15V, V_{IN} = 5V$	—	0.3	0.45	mA
ON Threshold Voltage	$V_{th(on)}$	Applied Between V_{IN} -GND	—	2.1	2.6	Volts
OFF Threshold Voltage	$V_{th(off)}$	Applied Between V_{IN} -GND	0.8	1.3	—	Volts
Supply Circuit Undervoltage	UV_{Dt}	Trip Level, $T_j \leq 125^\circ\text{C}$	10.3	—	12.5	Volts
Protection	UV_{Dr}	Reset Level, $T_j \leq 125^\circ\text{C}$	10.8	—	13.0	Volts

Thermal Characteristics, $T_j = 25^\circ\text{C}$ unless otherwise specified

Characteristic	Symbol	Condition	Min.	Typ.	Max.	Units
Thermal Resistance Junction to Case	$R_{th(j-C)Q}$	IGBT Part (Per 1 Chip)	—	—	0.96	$^\circ\text{C}/\text{Watt}$
Thermal Resistance Junction to Case	$R_{th(j-C)D}$	FWDi Part (Per 1 Chip)	—	—	1.35	$^\circ\text{C}/\text{Watt}$

Recommended Conditions for Use

Characteristic	Symbol	Condition	Min.	Typ.	Max.	Units
Input Supply Voltage	V_i	Applied between S-R	90	—	264	V_{rms}
Control Supply Voltage	V_D	Applied between V_D -GND	13.5	15.0	16.5	Volts
Control Supply Variation	ΔV_D		-1	—	1	$V/\mu\text{s}$
PWM Input Frequency	f_{PWM}	$T_C \leq 100^\circ\text{C}, T_j \leq 125^\circ\text{C}$	—	20	—	kHz

*H-Diode and L-Diode corresponds to Diode1, Diode 2 and Diode 3, Diode 4 in the Application circuit.

PS51787
 Intellimod™ Module
 Dual-In-Line Intelligent Power Factor Correction Module
 20 Amperes/600 Volts

Application Circuit

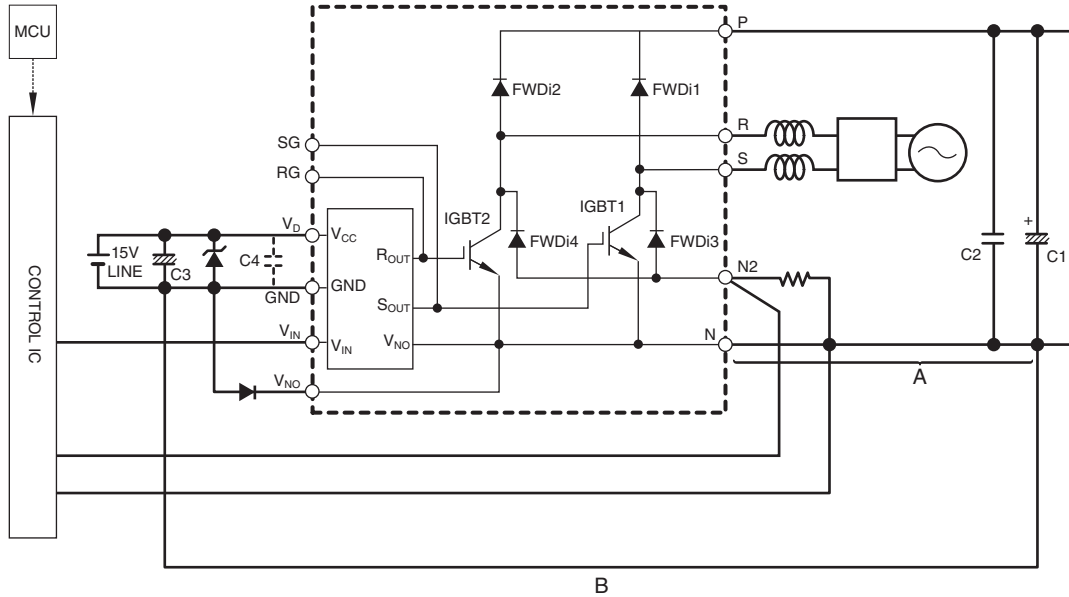

NOTE:

1. Due to high speed and large surge voltage switching, the area P-C1-N should be as small as possible. (C1: good temperature, frequency characteristic electrolytic type). Also add a bypass condenser (C2) with good frequency response such as polypropylene as close as possible to the P and N terminals.
2. To prevent erroneous protection, the wiring of A, B should be as short as possible.
3. It is recommended to insert a high-speed clamp diode between V_{NO}-GND terminals to prevent surge destruction.
4. C3 and C4 capacitors should be mounted as close to the terminals of the DIPFPC as possible. C3, good temperature, frequency characteristic electrolytic type and C4, good temperature, frequency and DC bias characteristic ceramic type are recommended.
5. It is recommended to insert a Zener diode (24V/1W) between each pair of control supply terminals to prevent surge destruction.
6. Please connect adjacent terminals with the same name together on the PCB. (N, N2, V_{NO}, V_{IN}, V_D, S)
7. Do not connect RG and SG terminals to any wire on the PCB.