



## BP2A – Universal Gate Drive Prototype Board

**Description:** The BP2A is a complete isolated interface circuit for dual V1-Series IPMs. This circuit features an optical isolation interface for the control signals and isolated power supplies for the IPM's built-in gate drive and protection circuits. The isolated interface helps to simplify prototype development and minimize design time by allowing direct connection of the IPM to logic level control circuits.

### Features:

- Complete isolated interface circuit with fault feedback
- 2500VRMS isolation for control power and signals
- Standard AMP MTA .100" Input Signal and Control Power Connectors
- Operates from a single 24 or 15VDC supply

### Applications:

BP2A is designed for use with Powerex any V1-Series IPM.

- **Use Powerex DC to DC converters for isolated control power:**  
VLA106-24151 for 24V input  
Or  
VLA106-15151 for 15V input

*Note: User must supply Optocouplers and passive components to fully populate the BP2A (See Table 2)*

## Isolated DC to DC Converters:

In order to simplify the design and layout of the required control power supplies Powerex has introduced the VLA106-24151, VLA106-15151 isolated DC to DC converters. Both DC to DC converters are designed to produce an isolated 15V DC output. The VLA106-15151 operates from a 15VDC source and the VLA106-24151 operates from a 24VDC source. Both DC to DC converters use transformers to provide 2500VRMS isolation between the primary and secondary side.

## Controller Interface:

A typical controller interface for the BP7B is shown in figure 1. An on signal (IPM control input low) is generated by pulling the respective control input low (GND) using a CMOS buffer capable of sinking at least 16mA (74HC04 or similar). In the off state the buffer should actively pull the control input high to maintain good noise immunity. Open collector drive that allows the control input to float will degrade common mode noise immunity and is therefore not recommended.

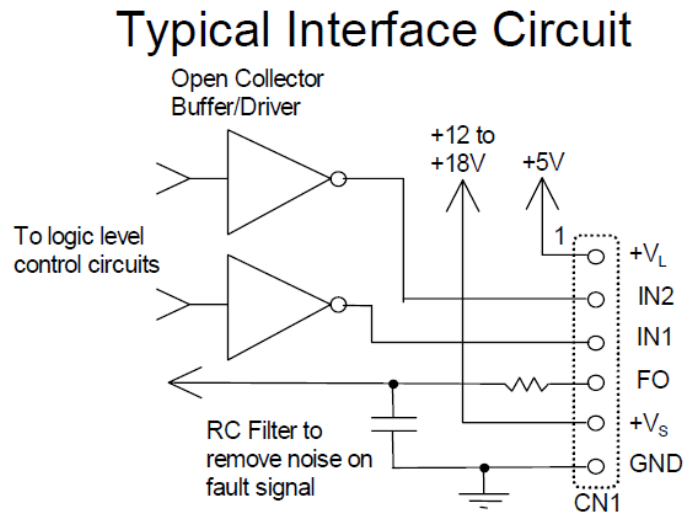

Figure 1

## Printed Circuit Layout:

Figure 2 shows the component layout of the BP2A interface circuit. The compact circuit board along with the IPM provides a complete isolated dual channel driving circuit with short circuit, over temperature and under voltage protection. This clearly demonstrates the advantage of using V1-Series Intelligent Power Modules. One important feature of this PCB is the use of separate shield plane islands for each of the isolated driving circuits, logic level interface, and control power supply. This layout is designed to prevent undesirable coupling of noise between the control side and the floating gate drive channels. The BP2A PCB is designed to plug directly onto the control pins of the V1-Series IPM. This configuration helps to maintain good noise immunity by providing minimal interconnection distance.

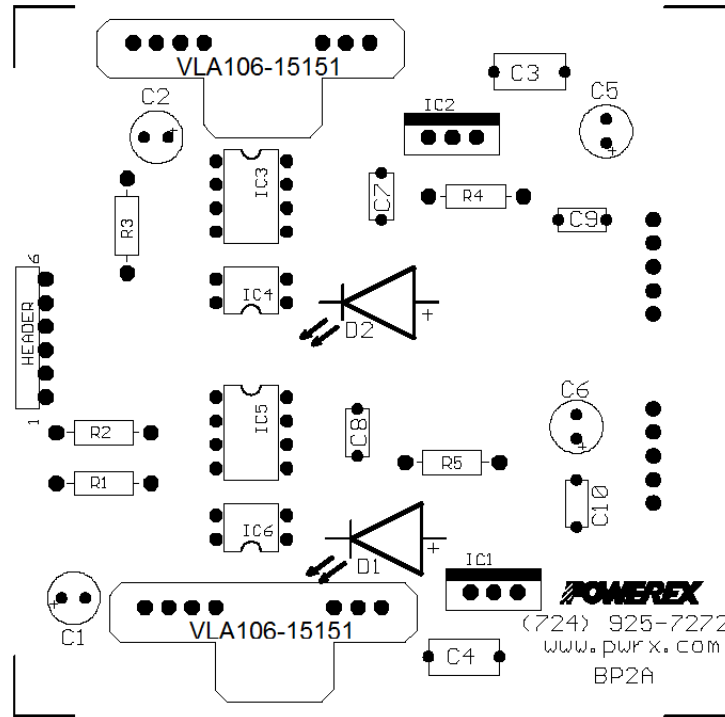

Figure 2

### BP2A Circuit Explanation:

A complete schematic of the BP2A interface circuit is shown in figure 3 and the bill of materials is given in Table 1. This circuit uses HCPL-4504 optocouplers to transfer logic level control signals between the system controller and the IPM. The optocouplers provide galvanic isolation to completely separate the controller from the high voltage in the power circuit. The BP2A also provides isolated control power supplies to power the IPMs built-in gate drive and protection circuits. An on signal is generated by turning on the internal optocoupler to pull the IPM's control input pin low.

The IPM's fault output signals are transferred back to the system controller using low speed PS2501 optocoupled transistors. During normal operation the fault feedback line is pulled high to the  $+V_L$  supply by the 4.7K resistor R1. When a fault condition is detected by the IPM it will immediately turn off the involved IGBT and pull its fault output pin low. The IPM's fault output has an open collector characteristic with an internal 1.5k ohm limiting resistor. Current flows from the +15V local isolated supply to the low speed optocoupler. The optocoupler's transistor turns on and its collector pulls the fault feedback line low to indicate a fault. Slow optos are used because they offer the advantages of lower cost and higher current transfer ratios. High speed is not necessary because the IPM disables a faulted device and produces a fault signal for a minimum of 1ms.

Isolated control power for the IPM is supplied by Powerex isolated DC to DC converters as described above. The circuit was originally designed with the obsolete M57145L in mind which only offered an isolated 24VDC at the output so an additional 15V regulator was required. When using the VLA106-15151 or VLA106-24151 DC/DC converters, please insert shorts as designated in Figure 3 so that the isolated 15VDC supply is fed directly to the IPM.

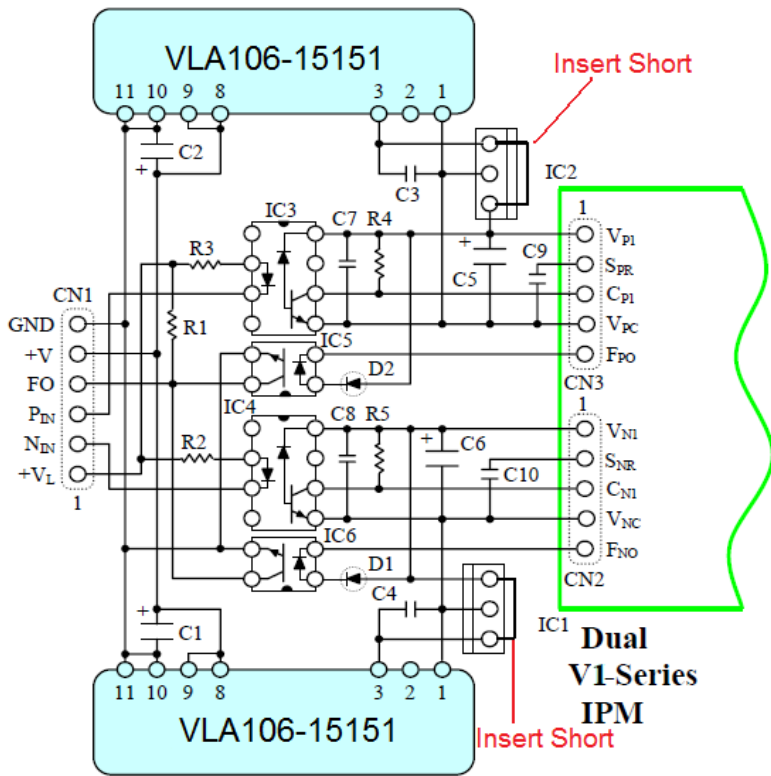

Figure 3

Table 1

**Board Parts List**

Designation	Description	Value	Example Type
C1,C2,C5,C6	DC supply filters. Low impedance long life electrolytic	82uF, 35V	Panasonic FC EEUFC1V820
C3, C4	<b>Not needed.</b>		
C7,C8,C9,C10	Local decoupling capacitors. Low impedance multi-layer ceramic	0.15uF, 50V	Panasonic ECUS1H154KBB
IC1, IC2	<b>Not needed. Insert short as per Figure 3</b>		
IC3, IC4	Control signal isolator - High speed Opto-coupler, High common mode noise immunity - 10KV/us minimum		HCPL4504
IC5, IC6	Fault signal isolator - Low speed Opto-coupler		NEC PS2501
R1	Fault signal pull-up	4.7K, 0.25W	
R2, R3	Control signal fast Opto LED current limiter	180ohm, 0.25W	
R4, R5	IPM control input pull-up	10K, 0.25W	
D1, D2	Fault indicator LED. High brightness red		Panasonic LN28WAL(US)
CN1	Input connector. MTA100 6 position right angle header with locking ramp		AMP 640457-6
CN2, CN3	Bottom entry 0.1" 5 position header receptacle		MOLEX 22-14-2054