

### Super Fast Recovery Single Diode Module 400 Amperes/1700 Volts

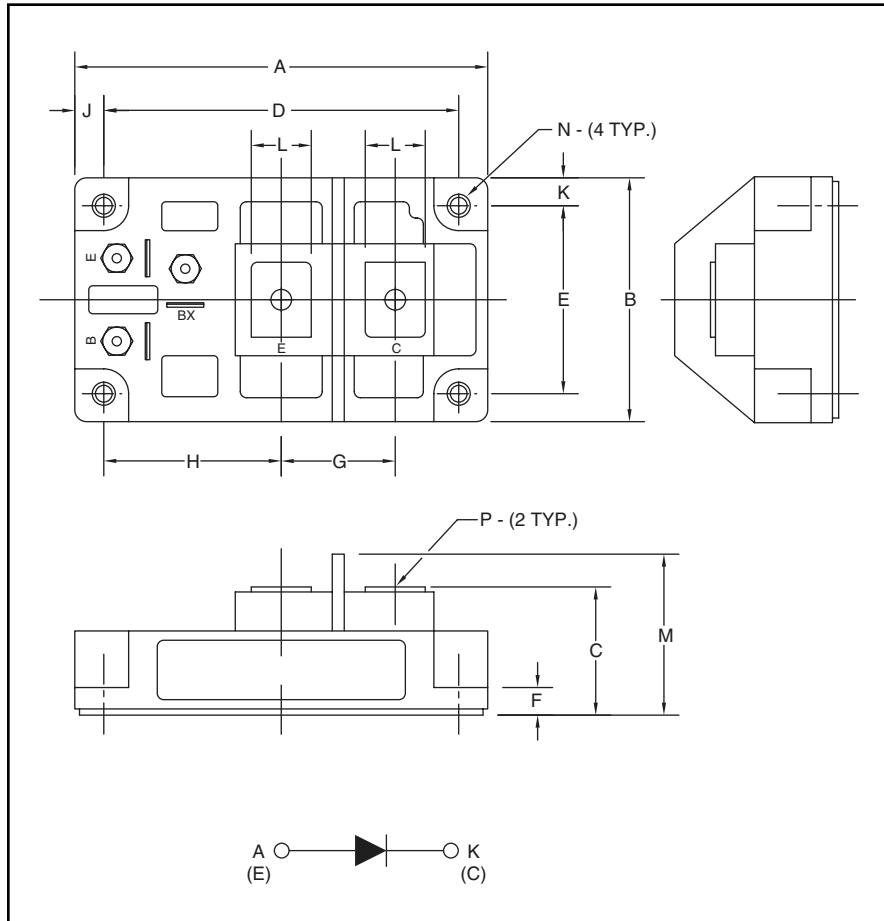

#### Description:

Powerex Super-Fast Recovery Single Diode Modules are designed for use in applications requiring fast switching. The modules are isolated for easy mounting with other components on common heatsinks.

#### Features:

- Isolated Mounting
- Planar Chips

#### Applications:

- Inverters
- Choppers
- Switching Power Supplies
- Free Wheeling

#### Ordering Information:

Select the complete ten digit module part number you desire from the table below.  
Example: RM400HA-34S is a 1700 Volt, 400 Ampere, Super Fast Recovery Single Diode Module.

Type	Current Rating Amperes	Voltage Volts (x50)
RM	400	34

#### Outline Drawing and Circuit Diagram

Dimension	Inches	Millimeters
A	4.25	108.0
B	2.44	62.0
C	1.38 +0.04/-0.02	35.0 +1.0/-0.5
D	3.66±0.01	93.0±0.25
E	1.88±0.01	48.0±0.25
F	0.28	7.0
G	1.14	29.0
H	1.83	46.5
J	0.29	7.5
K	0.28	7.0
L	0.63	16.0
M	1.61	41.0
N	0.26	6.5
P	M6	M6



Powerex, Inc., 200 E. Hillis Street, Youngwood, Pennsylvania 15697-1800 (724) 925-7272

**RM400HA-34S**  
**Super Fast Recovery**  
**Single Diode Module**  
400 Amperes/1700 Volts

### Absolute Maximum Ratings

Characteristics	Symbol	RM400HA-34S	Units
Peak Reverse Blocking Voltage	$V_{RRM}$	1700	Volts
Transient Peak Reverse Blocking Voltage (Non-Repetitive), $t < 5ms$	$V_{RSM}$	1700	Volts
DC Reverse Blocking Voltage	$V_{R(DC)}$	1360	Volts
DC Current, $T_C = 90^\circ C$	$I_{F(DC)}$	400	Amperes
Peak Half-Cycle Surge (Non-Repetitive) On-State Current (60Hz)	$I_{FSM}$	8000	Amperes
$I^2t$ (for Fusing), 8.3 milliseconds	$I^2t$	$2.6 \times 10^5$	$A^2sec$
Junction Temperature	$T_j$	-40 to 150	$^\circ C$
Storage Temperature	$T_{STG}$	-40 to 125	$^\circ C$
Maximum Mounting Torque M6 Mounting Screw	—	30	kg.-cm.
Maximum Mounting Torque M6 Terminal Screw	—	30	kg.-cm.
Module Weight (Typical)	—	450	Grams
V Isolation	$V_{RMS}$	3000	Volts

**RM400HA-34S**  
**Super Fast Recovery**  
**Single Diode Module**  
 400 Amperes/1700 Volts

**Electrical and Thermal Characteristics,  $T_j = 25^\circ\text{C}$  unless otherwise specified**

Characteristics	Symbol	Test Conditions	RM400HA-34S	Units
<b>Blocking State Maximums</b>				
Reverse Leakage Current, Peak	$I_{RRM}$	$V_{GE} = 0V, V_{RRM} = \text{Rated}$	50	mA
<b>Conducting State Maximums</b>				
Peak On-State Voltage	$V_{FM}$	$T_j = 25^\circ\text{C}, I_{FM} = 400A$	2.5	Volts
<b>Switching Minimums</b>				
Reverse Recovery Time	$t_{rr}$	$I_{FM} = 400A, T_j = 150^\circ\text{C}$ $di/dt = -800A/\mu s, V_R = 800V$	0.5	$\mu s$
Reverse Recovery Charge	$Q_{rr}$	$I_{FM} = 400A, T_j = 150^\circ\text{C}$ $di/dt = -800A/\mu s, V_R = 800V$	50	$\mu C$
<b>Thermal Maximums</b>				
Thermal Resistance, Junction-to-Case	$R_{\theta(J-C)}$	Per Module	0.08	$^\circ\text{C}/\text{Watt}$
Thermal Resistance, Case-to-Sink	$R_{\theta(C-S)}$	Per Module	0.04	$^\circ\text{C}/\text{Watt}$

**RM400HA-34S**  
**Super Fast Recovery**  
**Single Diode Module**  
 400 Amperes/1700 Volts

