

Hybrid IC IGBT Gate Driver

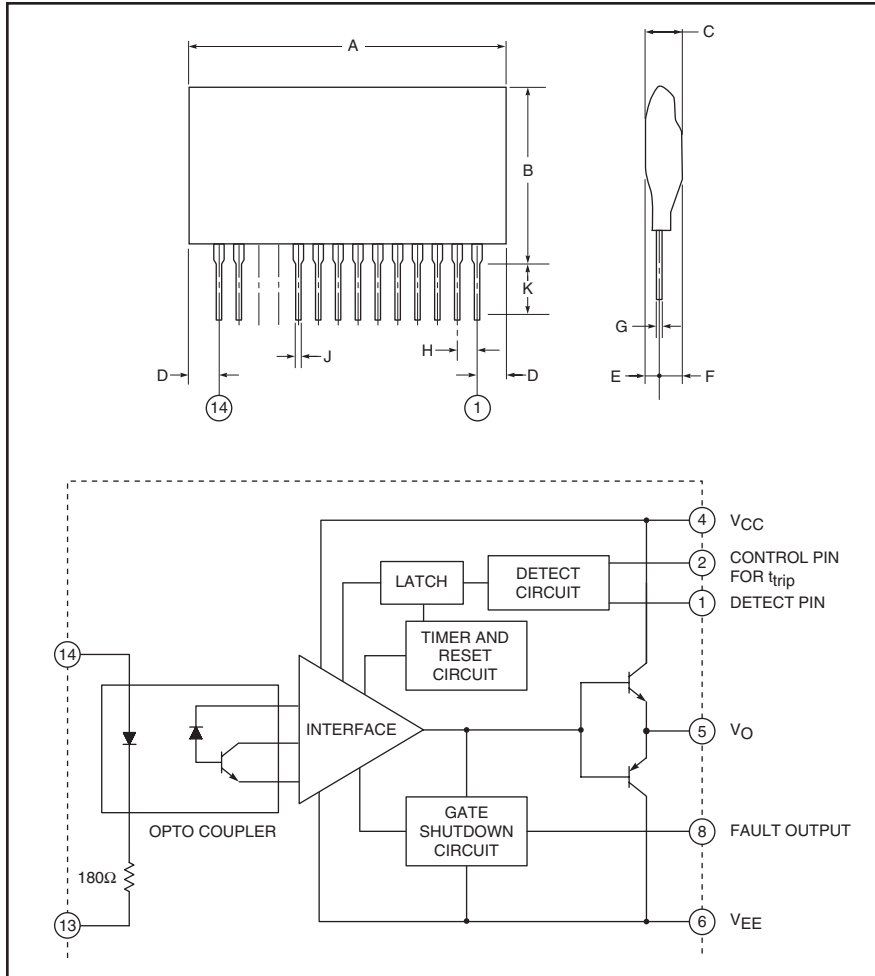

Outline Drawing and Circuit Diagram

Dimensions	Inches	Millimeters
A	1.69	43.0
B	0.94	24.0
C	0.4	10.0
D	0.2	5.0
E	0.12	3.0
F	0.3	7.5
G	0.01+0.01/-0.004	0.25+0.2/-0.1
H	0.10	2.54
J	0.02+0.006/-0.004	0.5+0.15/-0.1
K	0.18±0.06	4.5±1.5

Note: All dimensions listed are maximums except G, H, J, and K.

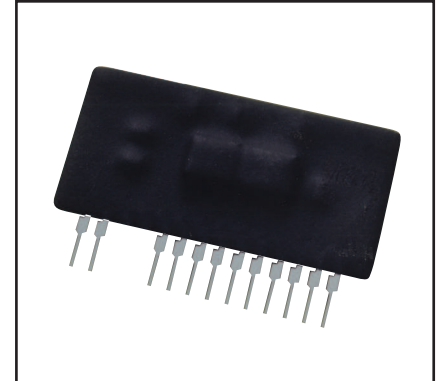

Description:

The VLA504-01 is a hybrid integrated circuit designed to provide optimum gate drive for IGBT modules. This device provides high current optically isolated gate drive with a large output voltage swing. The driver also provides short circuit protection based on desaturation detection.

Features:

- Electrical Isolation Voltage Between Input and Output with Opto-coupler (2500 V_{rms} for 1 Minute)
- Two Supply Driver Topology
- Built-in Short-Circuit Protection (With a Pin for Fault Output)
- TTL Compatible Input Interface

Application:

To drive IGBT modules for inverter or AC servo systems applications

Recommended IGBT Modules:

600V module up to 200A
1200V module up to 100A

VLA504-01
Hybrid IC IGBT Gate Driver

Absolute Maximum Ratings, $T_a = 25^\circ\text{C}$ unless otherwise specified

Characteristics	Symbol	VLA504-01	Units
Supply Voltage, DC	V_{CC}	18	Volts
	V_{EE}	-15	Volts
Input Signal Voltage (Applied between Pin 13 - 14, 50% Duty Cycle, Pulse Width 1ms)	V_i	-1 ~ +7	Volts
Output Voltage (When the Output Voltage is "H")	V_O	V_{CC}	Volts
Output Current (Pulse Width 2 μ s, $f \leq 20\text{kHz}$)	I_{OHP}	-3	Amperes
	I_{OLP}	3	Amperes
Isolation Voltage (Sine Wave Voltage 60Hz, for 1 Minute)	V_{ISO}	2500	V_{rms}
Case Temperature	T_C	85	$^\circ\text{C}$
Operating Temperature (No Condensation Allowable)	T_{opr}	-20 ~ +60	$^\circ\text{C}$
Storage Temperature (No Condensation Allowable)*	T_{stg}	-25 ~ +100	$^\circ\text{C}$
Fault Output Current (Applied Pin 8)	I_{FO}	20	mA
Input Voltage at Pin 1 (Applied Pin 1)	V_{R1}	50	Volts

*Differs from H/C condition.

Electrical and Mechanical Characteristics, $T_a = 25^\circ\text{C}$ unless otherwise specified, $V_{CC} = 15\text{V}$, $V_{EE} = -10\text{V}$

Characteristics	Symbol	Test Conditions	Min.	Typ.	Max.	Units
Supply Voltage	V_{CC}	Recommended Range	14	15	—	Volts
	V_{EE}	Recommended Range	-7	—	-10	Volts
Pull-up Voltage on Primary Side	V_{IN}	Recommended Range	4.75	5	5.25	Volts
"H" Input Current	I_{IH}	Recommended Range	15.2	16	19	mA
Switching Frequency	f	Recommended Range	—	—	20	kHz
Gate Resistance	R_G	Recommended Range	3	—	—	Ω
"H" Input Current	I_{IH}	$V_{IN} = 5\text{V}$	—	16	—	mA
"H" Output Voltage	V_{OH}		13	14	—	Volts
"L" Output Voltage	V_{OL}		-8	-9	—	Volts
"L-H" Propagation Time	t_{PLH}	$I_{IH} = 16\text{mA}$	—	0.4	1	μs
"L-H" Rise Time	t_r	$I_{IH} = 16\text{mA}$	—	0.3	1	μs
"H-L" Propagation Time	t_{PHL}	$I_{IH} = 16\text{mA}$	—	1	1.3	μs
"H-L" Fall Time	t_f	$I_{IH} = 16\text{mA}$	—	0.3	1	μs
Timer	t_{timer}	Between Start and Cancel (Under Input Sign "L")	1	—	2	ms
Fault Output Current	I_{FO}	Applied 8 Pin, $R = 4.7\text{k}\Omega$	—	5	—	mA
Controlled Time Detect Short-Circuit 1	t_{trip1}	Pin 1: 15V and More, Pin 2: Open	—	2.6	—	μs
Controlled Time Detect Short-Circuit 2**	t_{trip2}	Pin 1: 15V and More, Pins 2-4: 10pF (Connective Capacitance)	—	3	—	μs
SC Detect Voltage	V_{SC}	Collector Voltage of Module	15	—	—	Volts

**Length of wiring capacitor controlled time detect short-circuit is within 5cm from Pin 2 and Pin 4 coming and going.

VLA504-01
Hybrid IC IGBT Gate Driver

Application Circuit

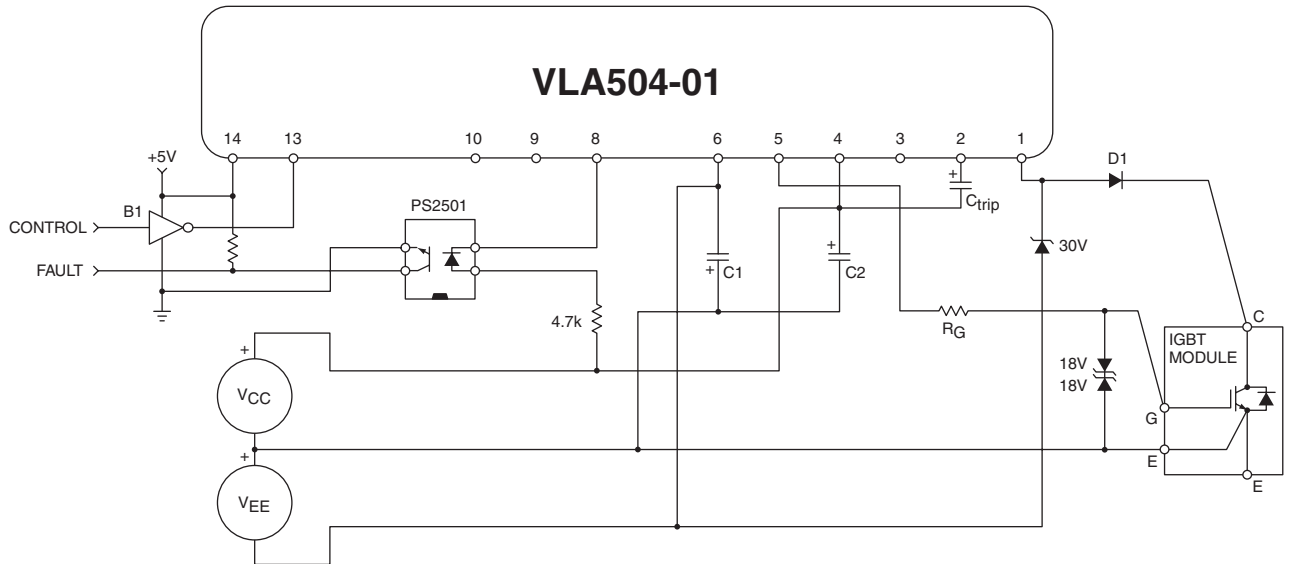

Component Selection:

Design	Description
VCC, VEE	+15V/-10V Typical. See data sheet for usable limits
RG	Adjust for application requirements. See IGBT module application notes for recommendations and power rating
C1, C2	10µF-100µF 25V low impedance electrolytic
D1	Ultra fast recovery $t_{rr} < 100\text{ns}$, High voltage $V_{rrm} > V_{ces}(\text{IGBT})$
Ctrip	0-200pF adjusts desaturation trip time (t_{trip})
B1	CMOS Buffer 74HC04 or similar – Must actively pull high to maintain noise immunity

Notes:

- (1) Power supply decoupling capacitors C1 and C2 should be connected as close as possible to the pins of the gate driver and must be sized to have appropriate ESR and ripple current capability for the IGBT being driven.
- (2) Ctrip should be connected as close as possible to the pins of the gate driver to avoid noise pick-up.
- (3) All zener diodes 1W, all resistors 0.25W unless otherwise noted.

Single Supply Operation

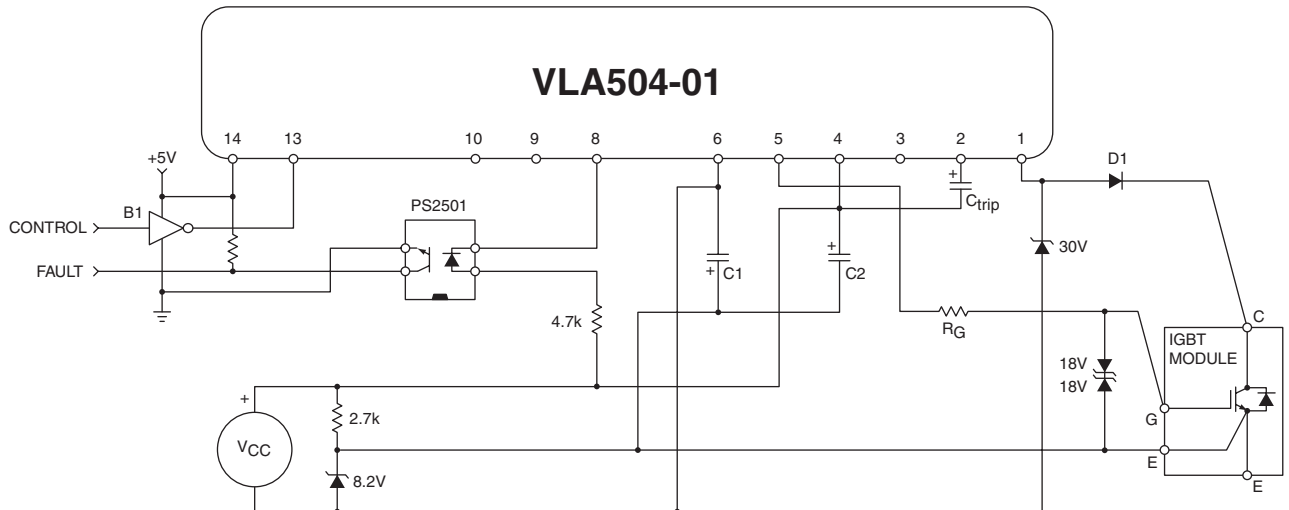

VLA504-01
Hybrid IC IGBT Gate Driver

PROPAGATION DELAY TIME VS. AMBIENT CHARACTERISTICS (TYPICAL)

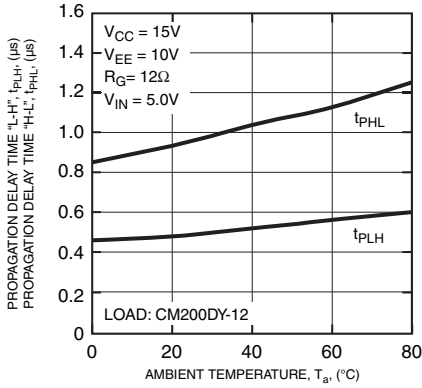

PROPAGATION DELAY TIME VS. INPUT VOLTAGE CHARACTERISTICS (TYPICAL)

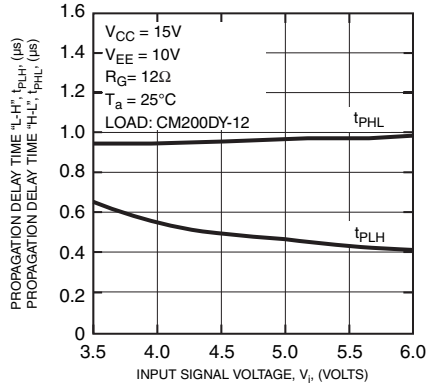

PROPAGATION DELAY TIME VS. AMBIENT TEMPERATURE CHARACTERISTICS (TYPICAL)

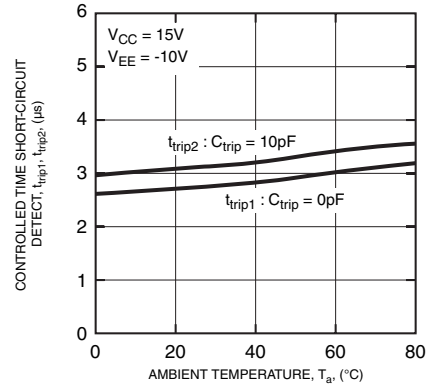

CONTROLLED TIME SHORT-CIRCUIT DETECT VS. CONNECTIVE CAPACITANCE CHARACTERISTICS (TYPICAL)

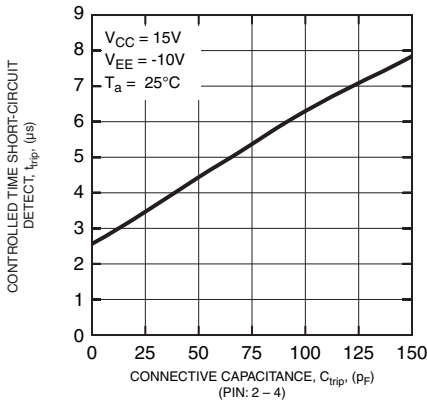

POWER DISSIPATION VS. AMBIENT TEMPERATURE CHARACTERISTICS (MAXIMUM RATING) (TYPICAL)

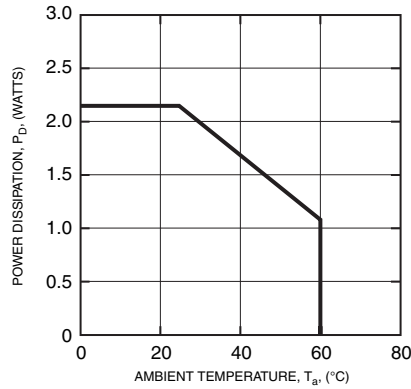

QUIESCENT CURRENT VS. SUPPLY VOLTAGE CHARACTERISTICS (PIN: 4 - 6) INPUT SIGNAL "L" (TYPICAL)

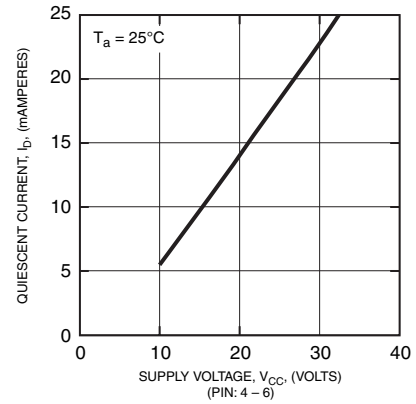

SWITCHING TIME DEFINITIONS

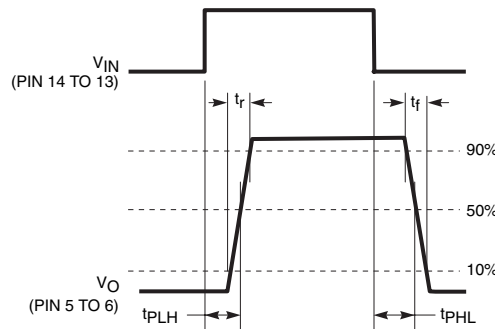

VLA504-01
Hybrid IC IGBT Gate Driver

General Description

The VLA504-01-01 is a hybrid integrated circuit designed to provide gate drive for high power IGBT modules. This circuit has been optimized for use with Powerex NF-Series and A-Series IGBT modules. However, the output characteristics are compatible with most MOS gated power devices. The VLA504-01 features a compact single-in-line package design. The upright mounting minimizes required printed circuit board space to allow efficient and flexible layout. The VLA504-01 converts logic level control signals into fully isolated +15V/-8V gate drive with up to 5A of peak drive current. Control signal isolation is provided by an integrated high speed opto-coupler. Short circuit protection is provided by means of desaturation detection.

Short Circuit Protection

Figure 1 shows a block diagram of a typical desaturation detector. In this circuit, a high voltage fast recovery diode (D1) is connected to the IGBT's collector to monitor the collector to emitter voltage. When the IGBT is in the off state, V_{CE} is high and D1 is reverse biased. With D1 off the (+) input of the comparator is pulled up to the positive gate drive power supply (V+) which is normally +15V. When the IGBT turns on, the comparators (+) input is pulled down by D1 to the IGBT's $V_{CE(sat)}$. The (-) input of the comparator is supplied with a fixed voltage (V_{TRIP}). During a normal on-state condition the comparator's (+) input will be less than V_{TRIP} and it's output will be low. During a normal off-state condition the comparator's (+) input will be larger than

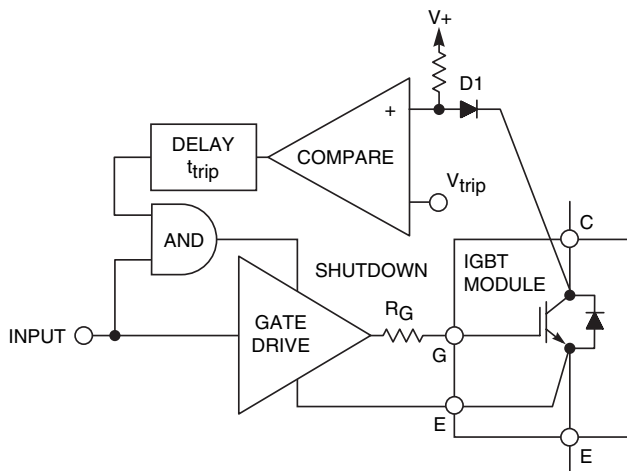

Figure 1. Desaturation Detector

V_{TRIP} and it's output will be high. If the IGBT turns on into a short circuit, the high current will cause the IGBT's collector-emitter voltage to rise above V_{TRIP} even though the gate of the IGBT is being driven on. This abnormal presence of high VCE when the IGBT is supposed to be on is often called desaturation. Desaturation can be detected by a logical AND of the driver's input signal and the comparator output. When the output of the AND goes high a short circuit is indicated. The output of the AND can be used to command the IGBT to shut down in order to protect it from the short circuit. A delay (t_{TRIP}) must be provided after the comparator output to allow for the normal turn on time of the IGBT. The t_{TRIP} delay is set so that the IGBTs Vce has enough time to fall below V_{TRIP} during normal turn on switching. If t_{TRIP} is set too short, erroneous desaturation detection will occur. The maximum allowable t_{TRIP} delay is limited by the IGBT's short circuit withstanding capability. In typical applications using Powerex IGBT modules the recommended limit is 10 μ s.

Operation of the VLA504-01 Desaturation Detector

The Powerex VLA504-01 incorporates short circuit protection using desaturation detection as described above. A flow chart for the logical operation of the short-circuit protection is shown in Figure 2. When a desaturation is detected the hybrid gate driver performs a soft shut down of the IGBT and starts a timed (t_{timer}) 1.5ms lock out. The soft turn-off helps to limit the transient voltage that may be generated while interrupting the large short circuit current flowing in the IGBT. During the lock out the driver pulls Pin 8 low to indicate the fault status. Normal operation of the driver will resume after the lock-out time has expired and the control input signal returns to its off state.

Adjustment of Trip Time

The VLA504-01 has a default short-circuit detection time delay (t_{TRIP}) of approximately 2.5 μ s. This will prevent erroneous detection of short-circuit conditions as long as the series gate resistance (R_G) is near the minimum recommended value for the module being used. The 2.5 μ s delay is appropriate for most applications so adjustment will not be necessary. However, in some low frequency applications it may be desirable to use a larger series gate resistor to slow the switching of the IGBT, reduce noise, and limit turn-off transient voltages. When R_G is increased, the switching delay time of the IGBT will also increase. If the delay

VLA504-01
Hybrid IC IGBT Gate Driver

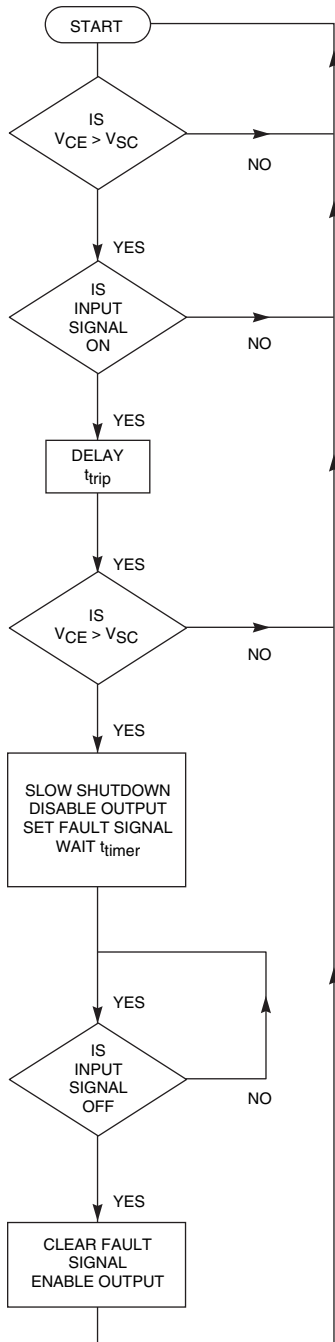

Figure 2. VLA504-01 Desaturation Detector

becomes long enough so that the voltage on the detect Pin 1 is greater than V_{SC} at the end of the t_{TRIP} delay the driver will erroneously indicate that a short circuit has occurred. To avoid this condition the VLA504-01 has provisions for extending the t_{TRIP} delay by connecting a capacitor (C_{TRIP}) between Pin 2 and V_{CC} (Pins 4). The effect of adding C_{TRIP} on trip time is shown in Figure 3. If t_{TRIP} is extended care must be exercised not to exceed the short-circuit withstanding capability of the IGBT module. Normally this will be satisfied for Powerex NF and A-Series IGBT modules as long as the total shut-down time does not exceed $10\mu s$.

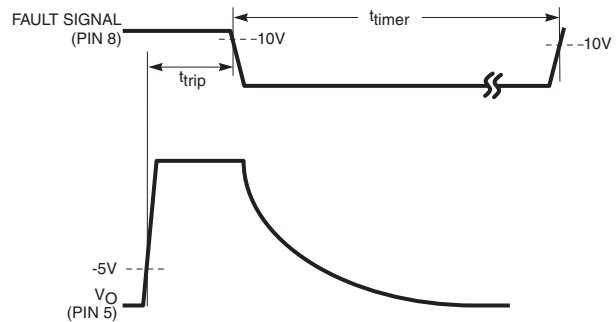

Figure 3. Adjustment of t_{trip}