

NX-Series Dual IGBT Gate Driver Interface Board

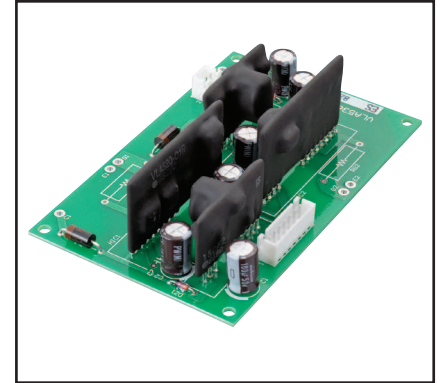
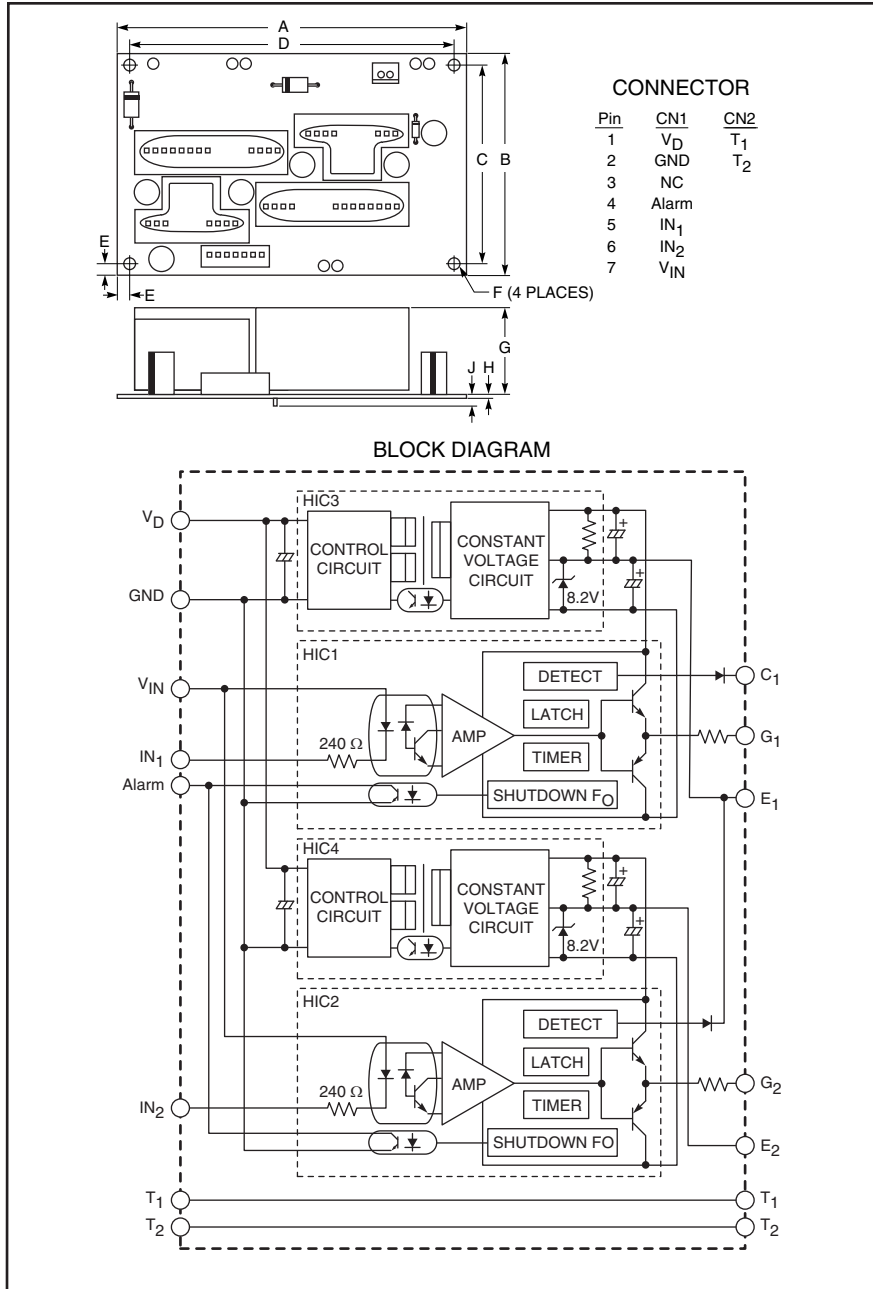

Description:

VLA536-01R is a completely populated gate driver board designed specifically for driving NX package style Powerex IGBT modules rated up to 450A at 1200V.

Features:

- Mounts Directly to Dual NX IGBT Modules
- Built-in Isolated DC-DC Converter for Gate Drive
- Built-in Short Circuit Protection
- Electrical Isolation Voltage is 2500 V_{rms} (for 1 minute)
- Provides Isolated Control Power and Gate Drive
- CMOS Compatible Input Interface

Recommended IGBT Modules:

NX-Series Dual IGBT Modules
600V – Up to 400A
(Example: CM400DX-12A)

1200V – Up to 450A
(Example: CM450DX-24A)

Application:

To drive IGBT modules for inverter or AC servo systems applications

Outline Drawing and Circuit Diagram

Dimensions	Inches	Millimeters
A	3.97±0.04	101.0±1.0
B	2.52±0.02	64.0±0.5
C	2.26	57.5
D	3.75	94.5
E	0.13	3.25

Dimensions	Inches	Millimeters
F	0.12 Dia.	3.0 Dia.
G	1.14 Max.	29.0 Max.
H	0.06	1.6
J	0.12 Max.	3.0 Max.



Powerex, Inc., 173 Pavilion Lane, Youngwood, Pennsylvania 15697 (724) 925-7272

VLA536-01R
 NX-Series Dual IGBT
 Gate Driver Interface Board

Absolute Maximum Ratings, $T_a = 25^\circ\text{C}$ unless otherwise specified

Characteristics	Symbol	VLA536-01R	Units
Supply Voltage (DC)	V_D	18	Volts
Input Signal Voltage (Applied between V_{IN} - IN_1 , IN_2 , 50% Duty Cycle, Pulse Width 1ms)	V_I	-1 ~ +7	Volts
Gate Peak Current	I_{OHP}	-5	A
(Pulse Width 2 μ s)	I_{OLP}	5	A
Operating Temperature (No Condensation)	T_{opr}	-20 ~ +70	$^\circ\text{C}$
Storage Temperature (No Condensation)	T_{stg}	-25 ~ +85	$^\circ\text{C}$
Alarm Pin Voltage	I_{alm}	10	mA
Gate Drive Current	V_{alm}	50	Volts
Gate Drive Current (Gate Average Current Per One Circuit)	I_{drive}	-	mA
Isolation Voltage (Sine Wave Voltage, 60Hz, 1 Minute)	V_{ISO}	2500	V_{Rms}

Electrical and Mechanical Characteristics, $T_a = 25^\circ\text{C}$, $V_D = 15\text{V}$ unless otherwise noted

Characteristics	Symbol	Test Conditions	Min.	Typ.	Max.	Units
Supply Voltage	V_D	Recommended Range	12	15	18	Volts
Input Voltage (Pull-up Voltage on Input Side)	V_{IN}	Recommended Range	4.75	5.0	5.25	Volts
Input Signal Current	I_{IH}	Recommended Range	10	13	16	mA
Switching Frequency	f	Recommended Range	-	-	20	kHz
Gate Resistance	R_G	Recommended Range	2	-	-	Ω
Alarm Output Current	I_{alm}	Recommended Range	-	-	5	mA
Plus Bias Voltage	V_{OH}		-	-	-	Volts
Minus Bias Voltage	V_{OL}		-	-	-	Volts
"L-H" Propagation Time	t_{PLH}	$I_{IH} = 13\text{mA}$	0.2	0.45	0.8	μs
"H-L" Propagation time	t_{PHL}	$I_{IH} = 13\text{mA}$	0.2	0.4	0.7	μs
Timer	t_{timer}	Between Start and Clear (Under Input Signal "OFF")	1.0	1.4	2.0	ms
Alarm Delay Time	t_{dalm}	$I_{alm} = 2.5\text{mA}$	-	6.5	10.0	μs
SC Detect Threshold Voltage	V_{SC}	IGBT Collector Voltage	-	-	-	Volts

VLA536-01R
NX-Series Dual IGBT
Gate Driver Interface Board

Inner Circuit

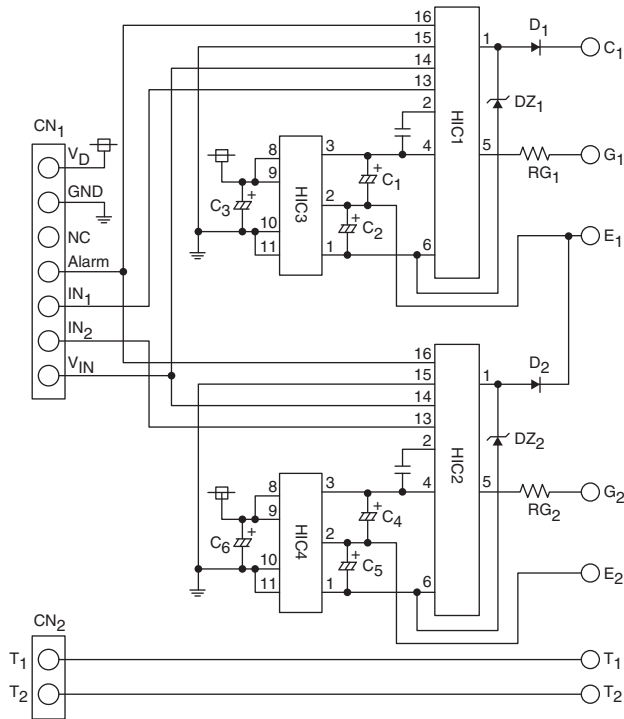

Parts List (Reference)

HIC ₁ , HIC ₂	VLA520-01R	ISAHAYA
HIC ₃ , HIC ₄	VLA106-15252	ISAHAYA
DZ ₁ , DZ ₂	30V, 500mW	
D ₁ , D ₂	RP1H	SanKen
C ₁ - 6	100µF, 50V	Low Impedance
C ₇ , C ₈	10pF ~ 50pF, 50V	TDK FK28 Type
RG ₁ , RG ₂	3W Class	
CN ₁	B7B-XH-A	JST
CN ₂	B2B-XH-A	JST

NOTE:

Gate Resistor is not included. Please install selected resistor.
 C₇, C₈ is not installed at the time of shipment. Please solder in selected capacitor if needed. (Rough Guide 10 ~ 50pF, 50V, Ceramic)

Application Example

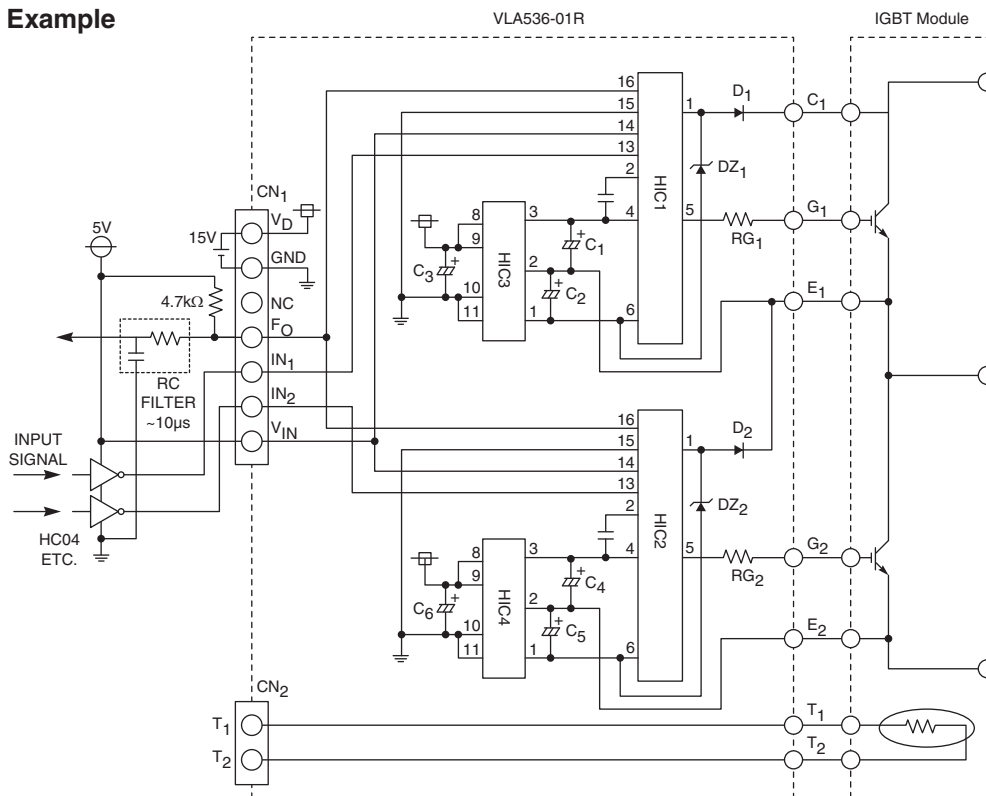

VLA536-01R
NX-Series Dual IGBT
Gate Driver Interface Board

Short Circuit Detection Flow Diagram

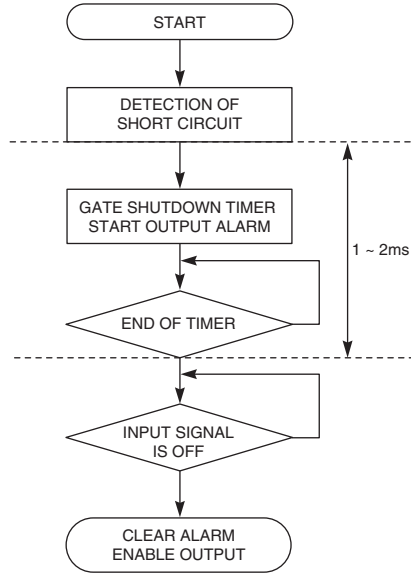

NOTE:
If the gate voltage is "H" and the collector voltage is high, the gate driver will recognize the circuit as a short circuit and immediately reduces the gate voltage (slow shutdown). It will also give an alarm signal showing that the SC protection circuit is operating.

The protection circuit resets if input signal is OFF when the predetermined time (1 ~ 2ms) has passed. (An OFF period of more than 40µm is required.)

PCB Installation

