

PAW3205DB-TJ3T
LOW POWER WIRELESS MOUSE SENSOR
General Description

The PAW3205DB-TJ3T is a high performance and low power CMOS process optical mouse sensor with DSP integration chip that serves as a non-mechanical motion estimation engine for implementing a computer wireless mouse. With adaptive frame-rate control(AFC), this optical mouse sensor gains extra power saving during mouse moving.

Features

- Single power supply
- Precise optical motion estimation technology
- Complete 2-D motion sensor
- Accurate motion estimation over a wide range of surfaces
- High speed motion detection up to 30 inches/sec
- High resolution up to 1600 CPI
- Power saving mode during times of no movement
- Serial interface for programming and data transfer
- Built-in low power Timer (LPT) for sleep1/sleep2 mode
- MOTSWK pin to wake up mouse controller
- Wide operation range from 2.1V to 3.6V
- Adaptive frame rate control for extra power saving during moving

Key Specification

Power Supply	Operating voltage 2.1V ~ 3.6V (VDD)
Optical Lens	1:1
Speed	Up to 30 inches/sec
Acceleration	Up to 10 G
Resolution	600/ 800/ 1000(Default)/ 1300/ 1600 CPI
Frame Rate	Up to 2400 frames/sec
Typical Operating Current (without I/O toggling)	1.5mA @ Mouse moving (Normal) 50uA @ Mouse not moving (Sleep1) 12uA @ Mouse not moving (Sleep2) 10uA @ Power down mode <i>*not including LED, typical value</i>
Package	Staggered DIP8

Ordering Information

Order Number	Part Description	Resolution
PAW3205DB-TJ3T	CMOS Optical Mouse Sensor	1000 CPI

1. Pin Configuration

1.1 Pin Description

Pin	Name	Type	Definition
1	NC	NC	No function
2	MOTSWK	OUT	Motion detect (active low output, see Section7)
3	SDIO	I/O	Serial interface bi-direction data
4	SCLK	IN	Serial interface clock
5	LED	OUT	LED control
6	VSS	GND	Chip ground
7	VDD	PWR	Power supply (2.1V~3.6V) for internal power regulator, VDDA (1.9V) is the power regulator output.
8	VDDA	PWR	Analog/Digital supply voltage (1.9V)

1.2 Pin Assignment

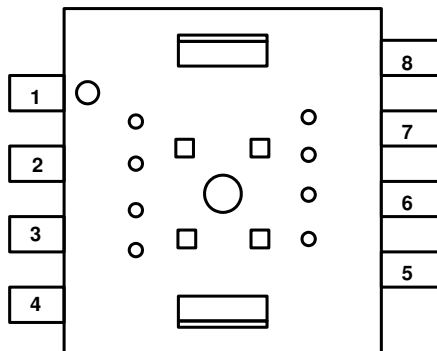

Figure 1. Top View Pinout

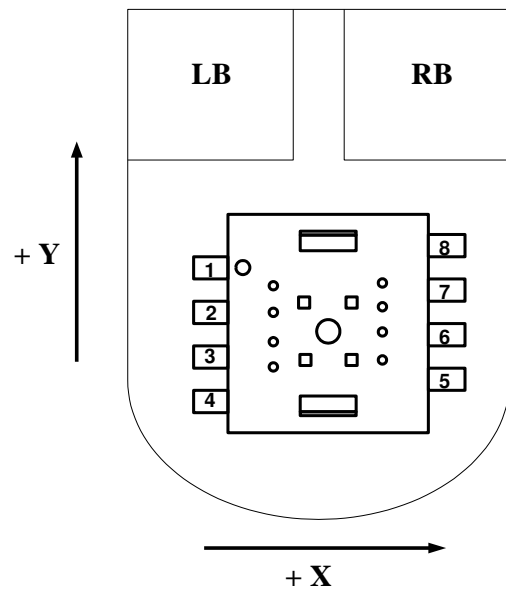

Figure 2. Top View of Mouse

2. Block Diagram and Operation

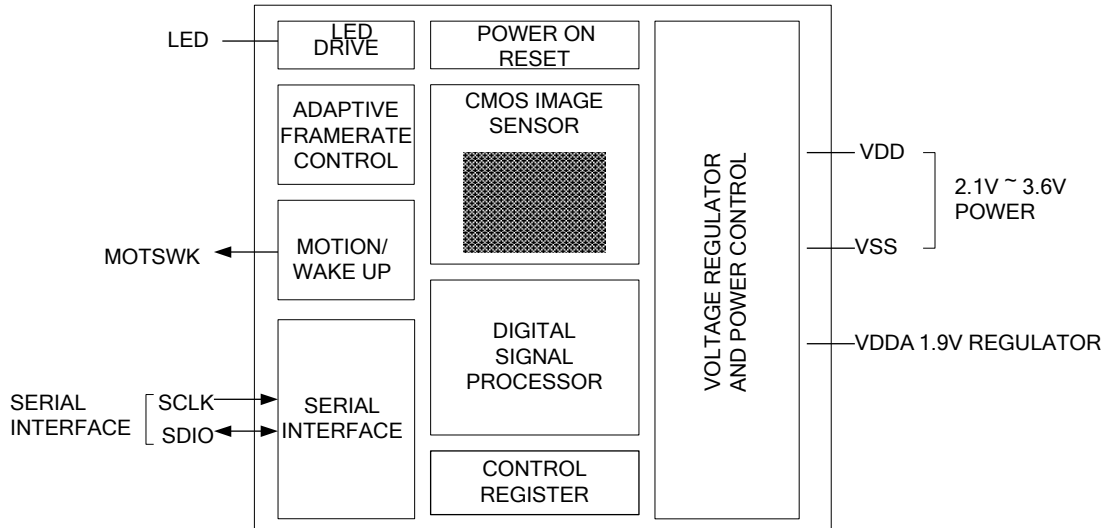

Figure 3. Block Diagram

The PAW3205DB-TJ3T is a high performance and low power CMOS-process optical mouse sensor with DSP integration chip that serves as a non-mechanical motion estimation engine for implementing a wireless computer mouse. It is based on new optical navigation technology, which measures changes in position by optically acquiring sequential surface images (frames) and mathematically determining the direction and magnitude of movement. The mouse sensor is in an 8-pin optical package. The current X and Y information are available in registers accessed via a serial port. The word "mouse sensor", instead of PAW3205DB-TJ3T, is used in the document.

With brand-new LED control technology, adaptive frame rate control (also known as AFC), the mouse sensor gain extra power saving during mouse moving. The AFC servers position/speed detection and then mapping to different frame rate. With lower frame rate, it leads to lower power consumption of the mouse sensor and LED. The mouse sensor is featured with THREE-level AFC which is 2400/1200/800 frame per second.

3. Registers and Operation

The mouse sensor can be programmed through registers via the serial port. Also, the DSP configuration and motion data can be read from these registers. All registers not listed are reserved, and should never be written by firmware.

3.1 Registers

Address	Name	R/W	Default	Data Type
0x00	Product_ID1	R	0x30	Eight bits[11:4] number with the product identifier
0x01	Product_ID2	R	0xDX	Upper Four bits[3:0] number with the product identifier Lower Four bits[3:0] number with the product version
0x02	Motion_Status	R	-	Bit field
0x03	Delta_X	R	-	Eight bits 2's complement number
0x04	Delta_Y	R	-	Eight bits 2's complement number
0x05	Operation_Mode	R/W	0xB8	Bit field
0x06	Configuration	R/W	0x02	Bit field
0x07	Image_Quality	R	-	Eight bits unsigned integer
0x08	Operation_State	R	-	Bit field
0x09	Write_Protect	R/W	0x00	Bit field
0x0A	Sleep1_Setting	R/W	0x70	Bit field
0x0B	Enter_Time	R/W	0x10	Bit field
0x0C	Sleep2_Setting	R/W	0x70	Bit field
0x0D	Image_Threshold	R/W	0x0A	Eight bits unsigned integer
0x0E	Image_Recognition	R/W	0xE5	Bit field

4. Referencing Application Circuit

4.1 Power 2.7V Application Circuit, no DC/DC (with Red LED, 2.4GHz Transceiver)

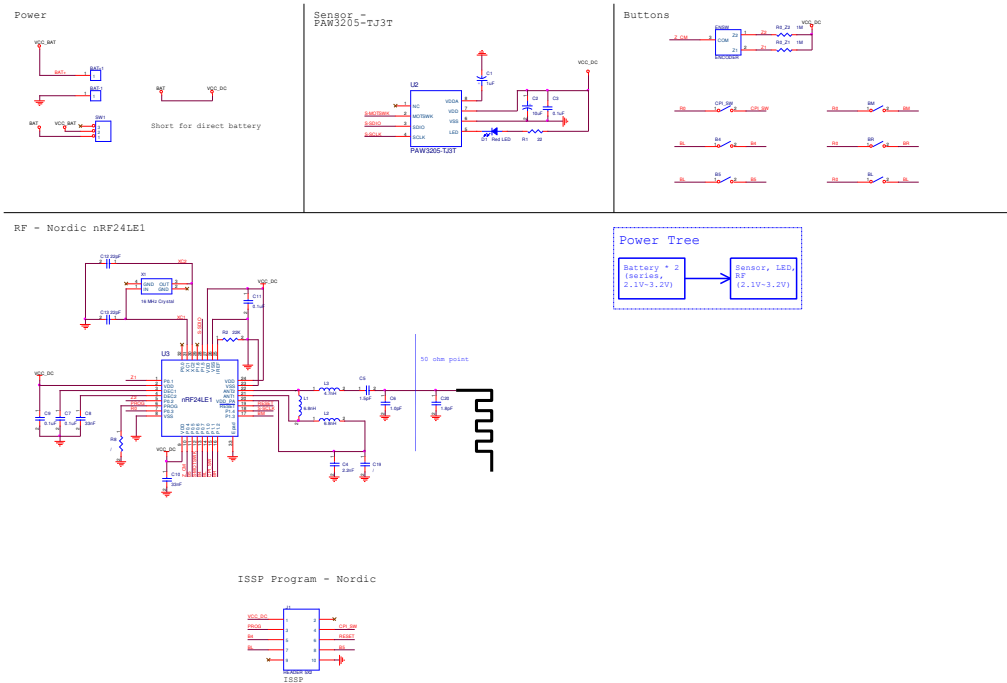

Figure 4. Application Circuit for 2.7V, no DC/DC

4.2 Power 2.7V Application Circuit, one DC/DC (with Red LED, 2.4GHz Transceiver)

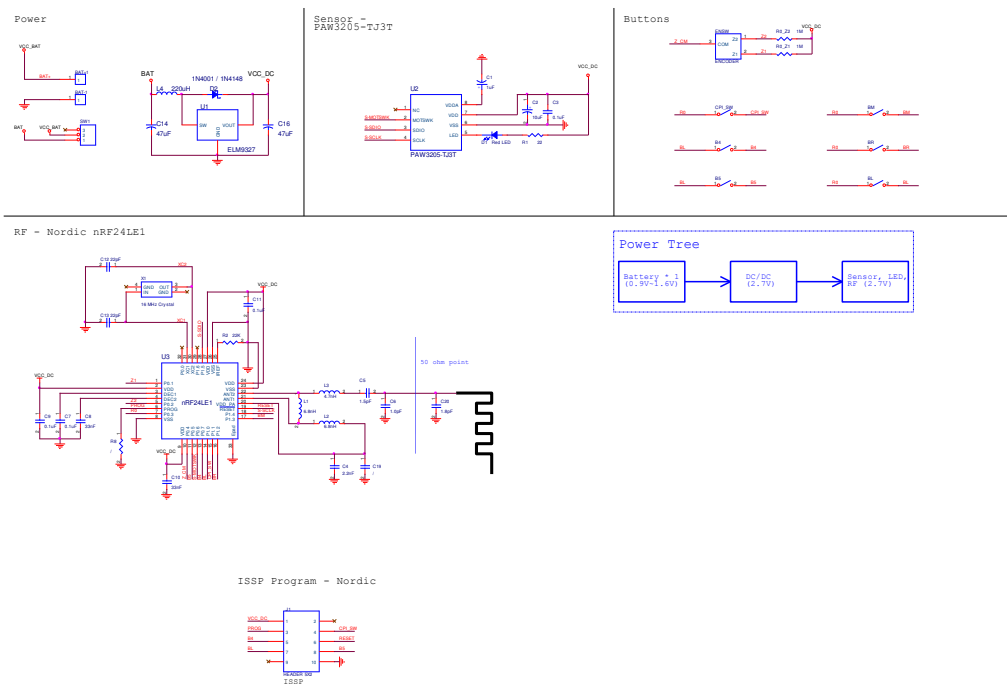

Figure 5. Application Circuit for 2.7V, one DC/DC