

---



---

**PAW3305DK OPTICAL MOUSE SENSOR**

---

**General Description**

The PAW3305DK is a CMOS process optical mouse sensor with DSP integration chip that serves as a non-mechanical motion estimation engine for implementing a computer mouse.

**Features**

- Single 5V power supply
- Precise optical motion estimation technology
- Complete 2-D motion sensor
- Accurate motion estimation over a wide range of surfaces
- High speed motion detection up to 68 inches/sec (@A4 Paper)
- High resolution up to 3200 CPI
- Register setting for low power dissipation (Power Down Mode)
- Serial Interface for programming and data transfer
- Internal oscillator accuracy within  $\pm 10\%$ , external resonator less
- IO 5V tolerance

**Key Specification**

<b>Power Supply</b>	<b>Operating voltage</b> 4.25V ~ 5.5V
<b>Optical Lens</b>	<b>1:1</b>
<b>Speed</b>	<b>68 inches/sec @ A4 paper</b>
<b>Acceleration</b>	<b>Up to 30g</b>
<b>Resolution</b>	<b>400/800/1200(Default)/ 1600/2000/2400/2800/3200 CPI</b>
<b>Frame Rate</b>	<b>3600 frames/sec</b>
<b>Operating Current</b>	<b>&lt;50mA @Mouse moving (Normal) &lt;100uA @Power-down mode</b>
<b>Package</b>	<b>Shrunk DIP12</b>

**Ordering Information**

<b>Order Number</b>	<b>I/O</b>	<b>Resolution</b>	<b>Tracking Speed</b>
PAW3305DK	CMOS output	1200 CPI	68 inches/sec @ A4 paper

**1. Pin Configuration**

**1.1 Pin Description**

Pin No.	Name	Type	Definition
1	SCLK	IN	Serial interface clock. (Open drain)
2	SDIO	I/O	Serial interface bi-direction data. (Open drain)
3	MOTSWK	OUT	Motion detect, active low output. (Open drain)
4	VDDQ	BYPASS	Chip digital power 3.3V. Please connect to 1uF capacitor.
5	VSSLED	GND	Chip LED ground
6	LED	OUT	LED control
7	NC	-	Connect to ground
8	VSS	GND	Chip ground
9	VDDD	BYPASS	Chip digital power 1.8V. Please connect to 1uF capacitor.
10	VDDA	BYPASS	Chip analog power 1.8V. Please connect to 1uF capacitor.
11	VDDAY	BYPASS	Chip image power 1.8V. Please connect to 10uF capacitor.
12	VDD	PWR	Power supply (4.25V-5.5V) for internal power regulator; VDDA, VDDD and VDDQ are the power regulator outputs.

**1.2 Pin Assignment**

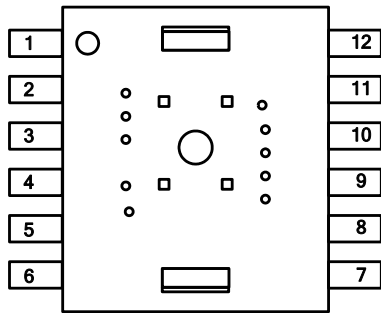

Figure 1. Top View Pinout

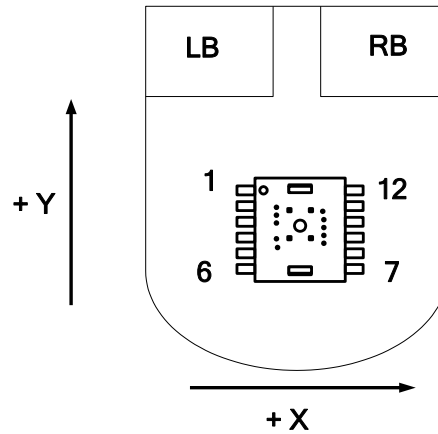

Figure 2. Top View of Mouse

2. Block Diagram and Operation

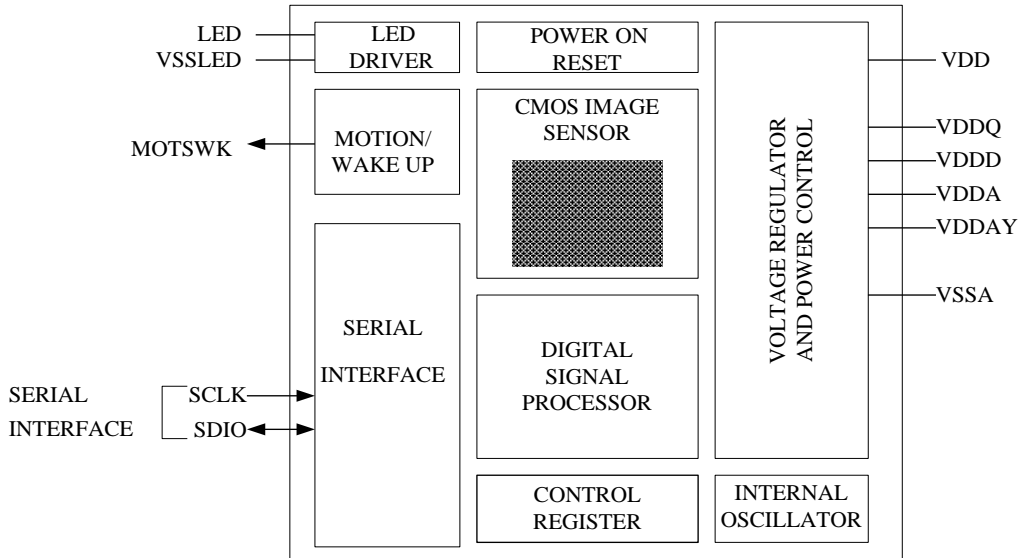

Figure 3. Block Diagram

The PAW3305DK is a high performance CMOS-process optical mouse sensor with DSP integration chip that serves as a non-mechanical motion estimation engine for implementing a computer mouse. It is based on new optical navigation technology, which measures changes in position by optically acquiring sequential surface images (frames) and mathematically determining the direction and magnitude of movement. The mouse sensor is in a 12-pin optical package. The current X and Y information are available in registers accessed via a serial port. The word "mouse sensor," instead of PAW3305DK, is used in the document.

### 3. Registers and Operation

The released registers of the mouse sensor can be programmed via a serial port interface. The user can modify released DSP configuration and read motion data from these registers. Some registers not being listed are reserved not allowed to be modified.

#### 3.1 Registers

Address	Name	R/W	Default	Data Type
0x00	Product_ID1	R	0x30	Eight bits[11:4] number with the product identifier
0x01	Product_ID2	R	0xAX	Four bits[3:0] number with the product identifier Reserved[3:0] number is reserved for future use
0x02	Motion_Status	R	-	Bit field
0x03	Delta_X	R	-	Eight bits 2's complement number
0x04	Delta_Y	R	-	Eight bits 2's complement number
0x05	Operation_Mode	R/W	0x80	Bit field
0x06	Configuration	R/W	0x02	Bit field
0x07	Image_Quality	R	-	Eight bits unsigned integer
0x08	Operation_State	R	-	Bit field
0x09	Write_Protect	R/W	0x00	Bit field
0x0A	Sleep1_Setting	R/W	0x42	Bit field
0x0B	Enter_Time	R/W	0x30	Bit field
0x0D	Image_Threshold	R/W	0x1E	Eight bits unsigned integer
0x0E	Image_Recognition	R/W	0xE3	Bit field
0x0F	Image_Data	R/W	0x40	Bit field

4. Referencing Application Circuit

4.1 Recommended Typical Application

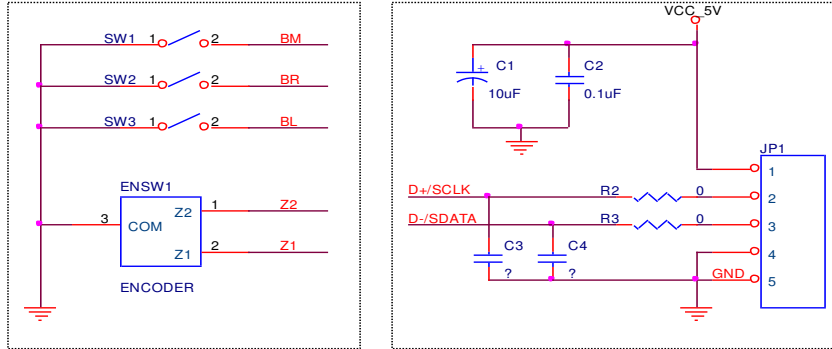

Button&Z Wheel

USB

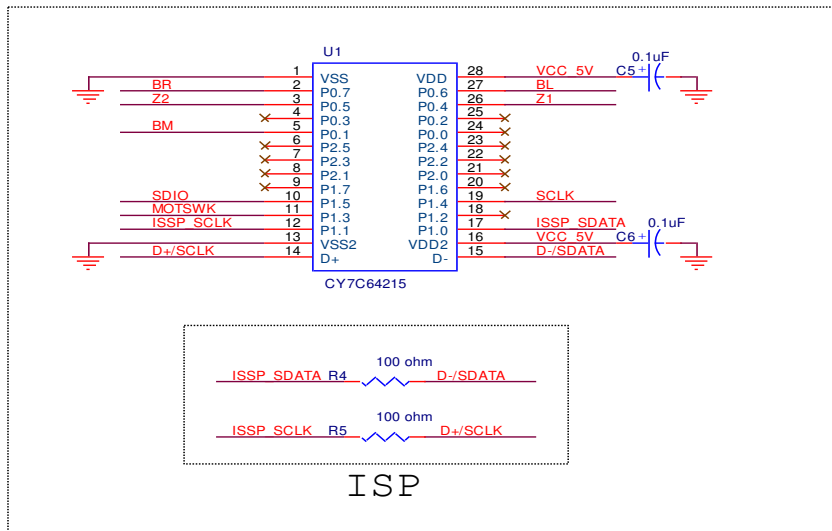

ISP

MCU

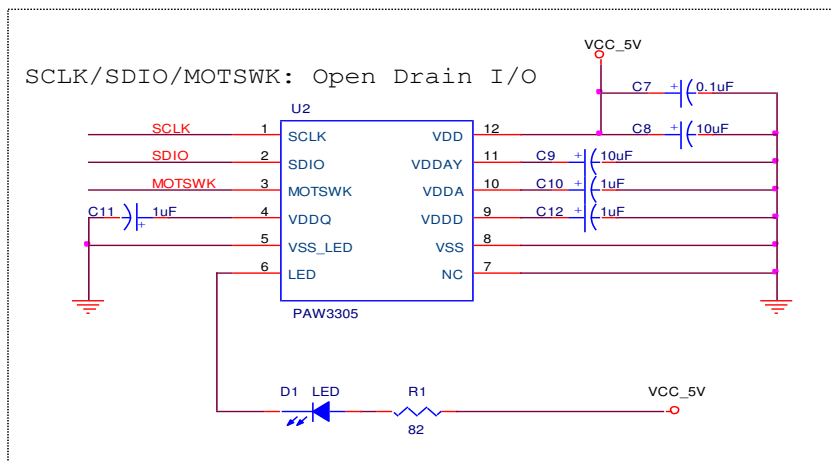

PAW3305 Sensor

Figure 4. Application Circuit (with Red LED)