

# XC6121/XC6122 XC6123/XC6124 Series

TOREX

ETR0209-011

Voltage Detector with Watchdog Function and ON/OFF Control ( $V_{DF}=1.6V\sim 5.0V$ )

## ■ GENERAL DESCRIPTION

The XC6121/XC6122/XC6123/XC6124 series is a group of high-precision, low current consumption voltage detectors with watchdog functions incorporating CMOS process technology. The series consist of a reference voltage source, delay circuit, comparator, and output driver. With the built-in delay circuit, the series do not require any external components to output signals with release delay time. The output type is  $V_{DFL}$  low when detected. The EN/ENB pin can control ON and OFF of the watchdog functions. By setting the EN/ENB pin to low or high level, the watchdog function can be OFF while the voltage detector remains operation. Since the EN/ENB pin of the XC6122 and XC6124 series is internally pulled up to the  $V_{IN}$  pin or pulled down to the  $V_{SS}$  pin, these series can be used with the EN/ENB pin left open when the watchdog functions is used. The detect voltages are internally fixed 1.6V ~ 5.0V in increments of 0.1V, using laser trimming technology. Six watchdog timeout periods are available in a range from 50ms to 1.6s. Five release delay times are available in a range from 3.13ms to 400ms.

## ■ APPLICATIONS

- Microprocessor watchdog monitoring and reset circuits
- Memory battery backup circuits
- System power-on reset circuits
- Power failure detection

## ■ FEATURES

|   |  |
|---|--|
| <b>Detect Voltage Range</b>                       | : 1.6V ~ 5.0V, $\pm 2\%$<br>(0.1V increments)  |
| <b>Hysteresis Width</b>                           | : $V_{DFL} \times 5\%$ (TYP.)  |
| <b>Operating Voltage Range</b>                    | : 1.0V ~ 6.0V  |
| <b>Detect Voltage Temperature Characteristics</b> | : $\pm 100\text{ppm}/^\circ\text{C}$ (TYP.)  |
| <b>Output Configuration</b>                       | : N-channel open drain   |
| <b>Watchdog Pin</b>                               | : Watchdog input<br>If watchdog input maintains 'H' or 'L' within the watchdog timeout period, a reset signal is output from the RESETB pin. |
| <b>EN/ENB Pin</b>                                 | : When the EN/ENB pin voltage is set to low or high level, the watchdog function is forced off.  |
| <b>Release Delay Time</b>                         | : 400ms, 200ms, 100ms, 50ms, 3.13ms (TYP.)   |
| <b>Watchdog Timeout Period</b>                    | : 1.6s, 800ms, 400ms, 200ms, 100ms, 50ms (TYP.)  |
| <b>Operating Ambient Temperature</b>              | : $-40^\circ\text{C} \sim +85^\circ\text{C}$   |
| <b>Packages</b>                                   | : SOT-25, USP-6C   |
| <b>Environmentally Friendly</b>                   | : EU RoHS Compliant, Pb Free   |

## ■ TYPICAL APPLICATION CIRCUIT

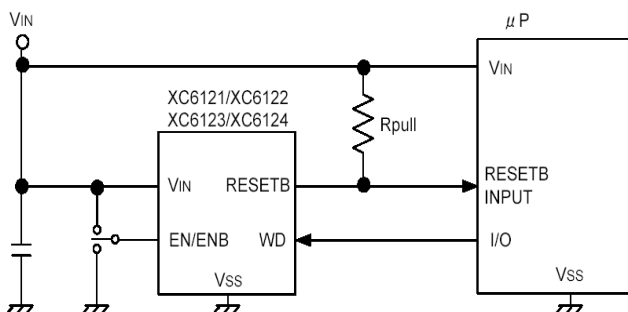

## ■ TYPICAL PERFORMANCE CHARACTERISTICS

- Supply Current vs. Input Voltage

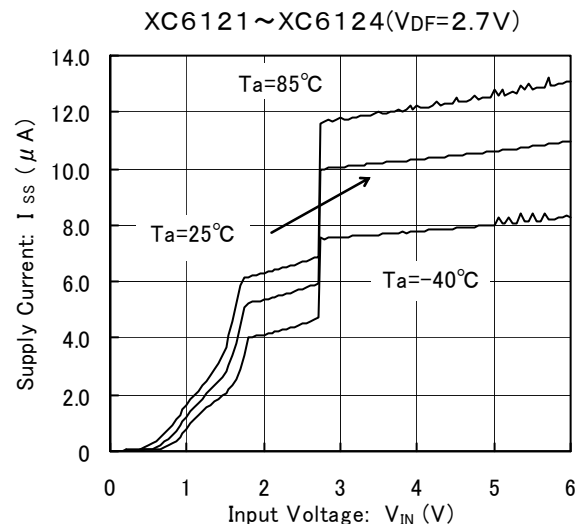

■ PIN CONFIGURATION



SOT-25  
(TOP VIEW)

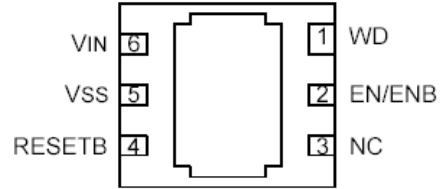

USP-6C  
(BOTTOM VIEW)

\* The dissipation pad for the USP-6C package should be solder-plated in reference mount pattern and metal masking so as to enhance mounting strength and heat release. If the pad needs to be connected to other pins, it should be connected to the Vss (No. 5) pin.

■ PIN ASSIGNMENT

| PIN NUMBER |        | PIN NAME        | FUNCTION                |
|------------|--------|-----------------|-------------------------|
| SOT-25     | USP-6C |                 |                         |
| 1          | 4      | RESETB          | Reset Output            |
| 2          | 5      | V <sub>SS</sub> | Ground                  |
| 3          | 2      | EN/ENB          | Watchdog ON/OFF Control |
| 4          | 1      | WD              | Watchdog                |
| 5          | 6      | V <sub>IN</sub> | Power Input             |
| -          | 3      | NC              | No Connection           |

## ■ PRODUCT CLASSIFICATION

### ● Selection Guide

| SERIES | RESET OUTPUT                             |                          | HYSTERESIS                                 | EN/ENB PIN FUNCTION                |                            |
|--------|--|--------------------------|--|------------------------------------|----------------------------|
|        | V <sub>DFL</sub> (RESETB) <sup>(*)</sup> | V <sub>DFH</sub> (RESET) |  | EN/ENB Input Logic <sup>(**)</sup> | Pull-Up or Down Resistor   |
| XC6121 | N-channel open drain                     | -                        | Available:<br>V <sub>DFL</sub> x 5% (TYP.) | EN                                 | With No Pull-Up Resistor   |
| XC6122 | N-channel open drain                     | -                        |  | EN                                 | With Pull-Up Resistor      |
| XC6123 | N-channel open drain                     | -                        |  | ENB                                | With No Pull-Down Resistor |
| XC6124 | N-channel open drain                     | -                        |  | ENB                                | With Pull-Down Resistor    |

<sup>(\*)</sup> The output type of RESETB is set to L level at the time of detection.

<sup>(\*\*)</sup> EN input logic: The watchdog function turns on when the EN pin becomes high level.

ENB input logic: The watchdog function turns on when the ENB pin becomes low level.

### ● Ordering Information

XC6121①②③④⑤⑥-⑦<sup>(\*)</sup>: N-channel Open Drain Output (RESETB), EN Pin: No Pull-Up Resistor

XC6122①②③④⑤⑥-⑦<sup>(\*)</sup>: N-channel Open Drain Output (RESETB), EN Pin: Pull-Up Resistor

XC6123①②③④⑤⑥-⑦<sup>(\*)</sup>: N-channel Open Drain Output (RESETB), ENB Pin: No Pull-Down Resistor

XC6124①②③④⑤⑥-⑦<sup>(\*)</sup>: N-channel Open Drain Output (RESETB), ENB Pin: Pull-Down Resistor

| DESIGNATOR          | ITEM                              | SYMBOL  | DESCRIPTION                           |
|---------------------|-----------------------------------|---------|---------------------------------------|
| ①                   | Release Delay Time <sup>(*)</sup> | A       | 3.13ms (TYP.)                         |
|                     |                                   | C       | 50ms (TYP.)                           |
|                     |                                   | D       | 100ms (TYP.)                          |
|                     |                                   | E       | 200ms (TYP.)                          |
|                     |                                   | F       | 400ms (TYP.)                          |
| ②                   | Watchdog Timeout Period           | 2       | 50ms (TYP.)                           |
|                     |                                   | 3       | 100ms (TYP.)                          |
|                     |                                   | 4       | 200ms (TYP.)                          |
|                     |                                   | 5       | 400ms (TYP.)                          |
|                     |                                   | 6       | 1.6s (TYP.)                           |
|                     |                                   | 7       | 800ms (TYP.)                          |
| ③④                  | Detect Voltage                    | 16 ~ 50 | Detect voltage<br>ex.) 4.5V: ③⇒4, ④⇒5 |
| ⑤⑥-⑦ <sup>(*)</sup> | Packages<br>(Order Unit)          | MR      | SOT-25 (3,000/Reel)                   |
|                     |                                   | MR-G    | SOT-25 (3,000/Reel)                   |
|                     |                                   | ER      | USP-6C (3,000/Reel)                   |
|                     |                                   | ER-G    | USP-6C (3,000/Reel)                   |

<sup>(\*)</sup> Please set the release delay time shorter than or equal to the watchdog timeout period.

ex.) XC6121D327MR or XC6121D627MR

<sup>(\*)</sup> The "-G" suffix denotes Halogen and Antimony free as well as being fully RoHS compliant.

■ BLOCK DIAGRAMS

● XC6121 Series

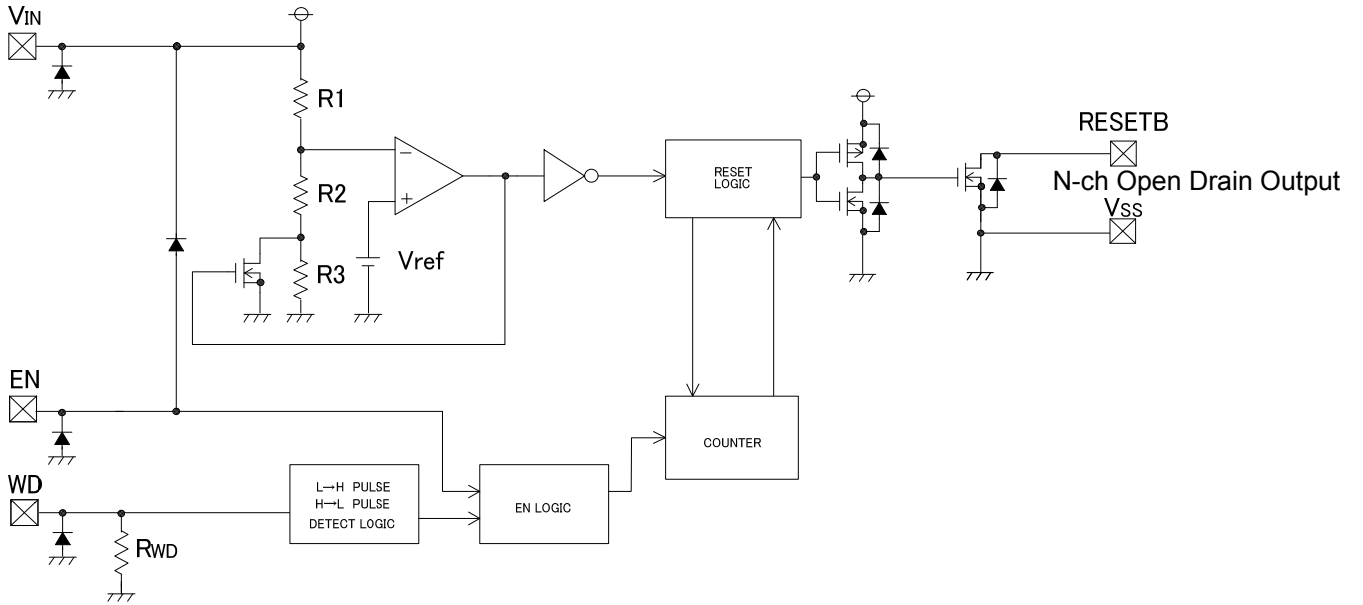

● XC6122 Series

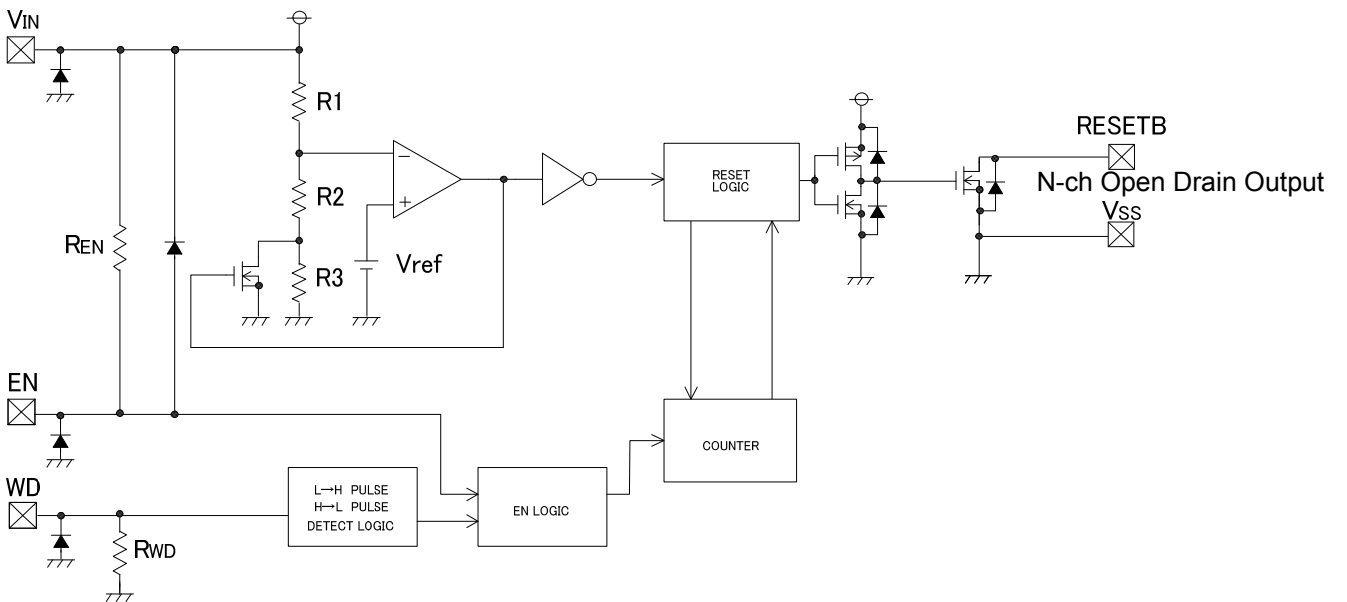

■ BLOCK DIAGRAMS (Continued)

● XC6123 Series

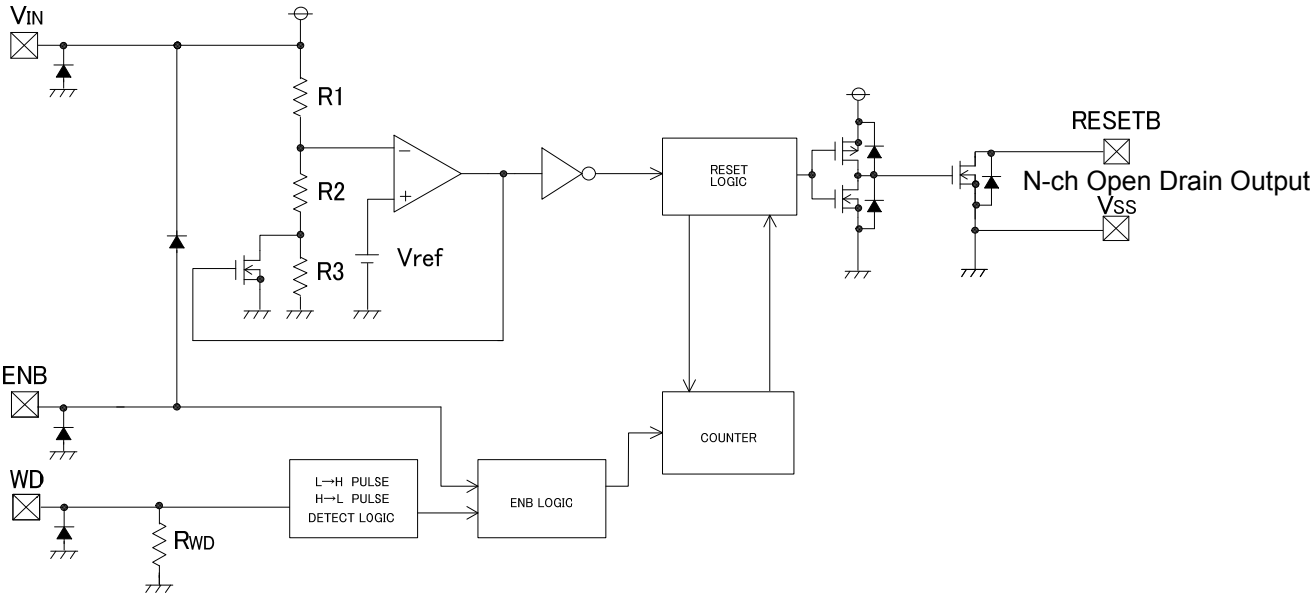

● XC6124 Series

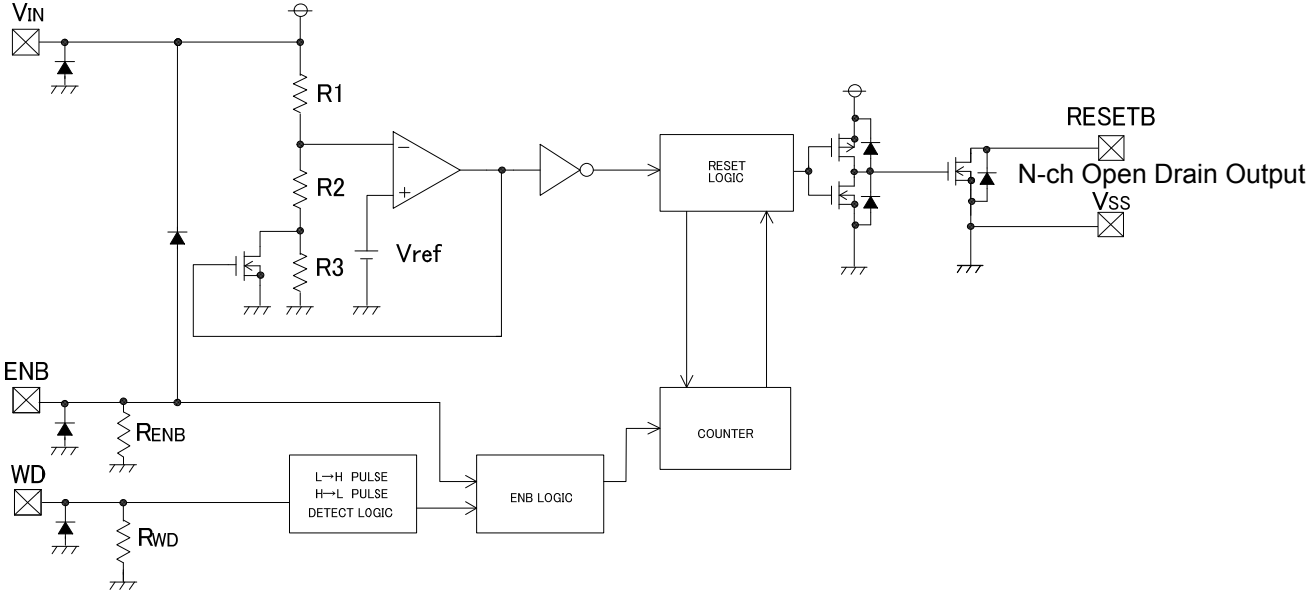

## ■ ABSOLUTE MAXIMUM RATINGS

Ta=25°C

| PARAMETER                     |        | SYMBOL                            | RATINGS                                       | UNITS |
|-------------------------------|--------|-----------------------------------|---|-------|
| Input Voltage                 |        | V <sub>IN</sub>                   | V <sub>SS</sub> -0.3 ~ 7.0                    | V     |
|                               |        | V <sub>EN</sub> /V <sub>ENB</sub> | V <sub>SS</sub> -0.3~V <sub>IN</sub> +0.3≤7.0 | V     |
|                               |        | V <sub>WD</sub>                   | V <sub>SS</sub> -0.3 ~ 7.0                    | V     |
| Output Current                |        | I <sub>RBOUT</sub>                | 20  | mA    |
| Output Voltage                |        | V <sub>RESETB</sub>               | V <sub>SS</sub> -0.3 ~ 7.0                    | V     |
| Power Dissipation             | SOT-25 | P <sub>d</sub>                    | 250   | mW    |
|                               | USP-6C |                                   | 120   |       |
| Operating Ambient Temperature |        | T <sub>opr</sub>                  | -40 ~ +85                                     | °C    |
| Storage Temperature           |        | T <sub>stg</sub>                  | -55 ~ +125                                    | °C    |

**■ ELECTRICAL CHARACTERISTICS**

Ta=25 °C

| PARAMETER  | SYMBOL  | CONDITIONS  | MIN.   | TYP.                    | MAX.                       | UNITS   | CIRCUIT |   |
|--|---|---|--|-------------------------|----------------------------|---------|---------|---|
| Detect Voltage                                   | VDFL  | V <sub>EN</sub> =V <sub>SS</sub>  | V <sub>DFL(T)</sub> × 0.98                         | V <sub>DFL(T)</sub>     | V <sub>DFL(T)</sub> × 1.02 | V       | ①       |   |
| Hysteresis Width                                 | VHYS  | V <sub>EN</sub> =V <sub>SS</sub>  | V <sub>DFL</sub> × 0.02                            | V <sub>DFL</sub> × 0.05 | V <sub>DFL</sub> × 0.08    | V       | ①       |   |
| Supply Current <sup>(*)</sup>                    | I <sub>SS</sub>                                       | WD=OPEN   | V <sub>IN</sub> =V <sub>DFL(T)</sub> ×0.9V         | -                       | 5                          | 11      | μA      | ② |
|  |   |   | V <sub>IN</sub> =V <sub>DFL(T)</sub> ×1.1V         | -                       | 10                         | 16      |         |   |
|  |   |   | V <sub>IN</sub> =6.0V                              | -                       | 12                         | 18      |         |   |
| Operating Voltage                                | V <sub>IN</sub>                                       |   | 1.0  | -                       | 6.0                        | V       | ①       |   |
| Output Current                                   | I <sub>R</sub> OUT                                    | N-ch.<br>V <sub>DS</sub> =0.5V  | V <sub>IN</sub> =1.0V                              | 0.15                    | 0.5                        | -       | mA      | ③ |
|  |   |   | V <sub>IN</sub> =2.0V (V <sub>DFL(T)</sub> > 2.0V) | 2.0                     | 2.5                        | -       |         |   |
|  |   |   | V <sub>IN</sub> =3.0V (V <sub>DFL(T)</sub> >3.0V)  | 3.0                     | 3.5                        | -       |         |   |
|  |   |   | V <sub>IN</sub> =4.0V (V <sub>DFL(T)</sub> >4.0V)  | 3.5                     | 4.0                        | -       |         |   |
| Temperature Characteristics                      | $\frac{\Delta V_{DFL}}{\Delta T_{opr} \cdot V_{DFL}}$ | -40°C ≤ T <sub>opr</sub> ≤ 85 °C  | -  | +100                    | -                          | ppm/ °C | ①       |   |
| Release Delay Time (V <sub>DFL</sub> ≤1.8V)      | t <sub>DR</sub>                                       | Time until V <sub>IN</sub> is increased from 1.0V to 2.0V and attains to the release time level, and the Reset output pin releases.                             | 2.00   | 3.13                    | 5.00                       | ms      | ④       |   |
|  |   |   | 37   | 50                      | 63                         |         |         |   |
|  |   |   | 75   | 100                     | 125                        |         |         |   |
|  |   |   | 150  | 200                     | 250                        |         |         |   |
|  |   |   | 300  | 400                     | 500                        |         |         |   |
| Release Delay Time (V <sub>DFL</sub> ≥1.9V)      | t <sub>DR</sub>                                       | Time until V <sub>IN</sub> is increased from 1.0V to (V <sub>DFL</sub> × 1.1V) and attains to the release time level, and the Reset output pin releases.        | 2.00   | 3.13                    | 5.00                       | ms      | ④       |   |
|  |   |   | 37   | 50                      | 63                         |         |         |   |
|  |   |   | 75   | 100                     | 125                        |         |         |   |
|  |   |   | 150  | 200                     | 250                        |         |         |   |
|  |   |   | 300  | 400                     | 500                        |         |         |   |
| Detect Delay Time                                | t <sub>DF</sub>                                       | Time until V <sub>IN</sub> is decreased from 6.0V to 1.0V and attains to the detect voltage level, and the Reset output pin detects while the WD pin left open. | -  | 5.5                     | 33                         | μs      | ④       |   |
| V <sub>DFL</sub> Leakage Current                 | I <sub>LEAK</sub>                                     | V <sub>IN</sub> =6.0V, V <sub>RESETB</sub> =6.0V  | -  | 0.01                    | 0.1                        | μA      | ③       |   |
| Watchdog Timeout Period (V <sub>DFL</sub> ≤1.8V) | t <sub>WD</sub>                                       | Time until V <sub>IN</sub> increases form 1.0V to 2.0V and the Reset output pin is released to go into the detection state. (WD=OPEN)                           | 37   | 50                      | 63                         | ms      | ⑤       |   |
|  |   |   | 75   | 100                     | 125                        |         |         |   |
|  |   |   | 150  | 200                     | 250                        |         |         |   |
|  |   |   | 300  | 400                     | 500                        |         |         |   |
|  |   |   | 600  | 800                     | 1000                       |         |         |   |
|  |   |   | 1200   | 1600                    | 2000                       |         |         |   |
| Watchdog Timeout Period (V <sub>DFL</sub> ≥1.9V) | t <sub>WD</sub>                                       | Time until V <sub>IN</sub> increases from 1.0V to (V <sub>DFL</sub> ×1.1V) and the Reset output pin is released to go into the detection state. (WD=OPEN)       | 37   | 50                      | 63                         | ms      | ⑤       |   |
|  |   |   | 75   | 100                     | 125                        |         |         |   |
|  |   |   | 150  | 200                     | 250                        |         |         |   |
|  |   |   | 300  | 400                     | 500                        |         |         |   |
|  |   |   | 600  | 800                     | 1000                       |         |         |   |
|  |   |   | 1200   | 1600                    | 2000                       |         |         |   |

■ ELECTRICAL CHARACTERISTICS (Continued)

Ta=25 °C

| PARAMETER                                 | SYMBOL                              | CONDITIONS  | MIN.                  | TYP. | MAX.                  | UNITS | CIRCUIT |
|---|-------------------------------------|---|-----------------------|------|-----------------------|-------|---------|
| Watchdog Minimum Pulse Width              | tWDIN                               | V <sub>IN</sub> =6.0V, Apply pulse from 6.0V to 0V to the WD pin.                     | 300                   | -    | -                     | ns    | ⑥       |
| Watchdog High Level Voltage               | VWDH                                | V <sub>IN</sub> =V <sub>DFL</sub> x 1.1V ~ 6.0V                                       | V <sub>IN</sub> x 0.7 | -    | 6                     | V     | ⑥       |
| Watchdog Low Level Voltage                | VWDL                                | V <sub>IN</sub> =V <sub>DFL</sub> x 1.1V ~ 6.0V                                       | 0                     | -    | V <sub>IN</sub> x 0.3 | V     | ⑥       |
| Watchdog Pull-down Resistance             | RWD                                 | VWD=6V, RWD=VWD/IWD   | 300                   | 600  | 900                   | kΩ    | ⑦       |
| EN/ENB High Level Voltage                 | V <sub>ENH</sub> /V <sub>ENBH</sub> | V <sub>IN</sub> =V <sub>DFL</sub> x 1.1V ~ 6.0V                                       | 1.3                   | -    | V <sub>IN</sub>       | V     | ⑧       |
| EN/ENB Low Level Voltage                  | V <sub>ENL</sub> /V <sub>ENBL</sub> | V <sub>IN</sub> =V <sub>DFL</sub> x 1.1V ~ 6.0V                                       | 0                     | -    | 0.35                  | V     | ⑧       |
| EN Pull-up Resistance <sup>(*)2)</sup>    | REN                                 | V <sub>IN</sub> =6.0V, V <sub>EN</sub> =0V, REN=V <sub>IN</sub> / I <sub>EN</sub>     | 1.0                   | 1.6  | 2.4                   | MΩ    | ⑨       |
| ENB Pull-down Resistance <sup>(*)3)</sup> | RENB                                | V <sub>IN</sub> =6.0V, V <sub>ENB</sub> =6V, RENB=V <sub>ENB</sub> / I <sub>ENB</sub> |                       |      |                       |       |         |

NOTE:

\* In case where no EN/ENB pin's condition written in the test condition field, V<sub>EN</sub>=V<sub>IN</sub> and V<sub>ENB</sub>=V<sub>SS</sub>.

\*\* V<sub>DFL(T)</sub>=Setting detect voltage value

(<sup>\*)1</sup>) The condition when the watchdog pin is ON.

The EN/ENB pin is CMOS input. For the XC6122 (pull-up resistor) and XC6124 (pull-down resistor), supply current increases in the following values when the watchdog function is OFF.

XC6122 Series : (V<sub>IN</sub>-V<sub>EHL</sub>) /1.6MΩ (TYP.)

XC6124 Series : V<sub>ENBH</sub>/1.6MΩ (TYP.)

(<sup>\*)2</sup>) For the XC6122 series only.

(<sup>\*)3</sup>) For the XC6124 series only.



## ■ OPERATIONAL EXPLANATION

The XC6121/6122/6123/6124 series compare, using the error amplifier, the voltage of the internal voltage reference source with the voltage divided by R1, R2 and R3 connected to the VIN pin. The resulting output signal from the error amplifier activates the watchdog logic, delay circuit and the output driver. When the VIN pin voltage gradually falls and finally reaches the detect voltage, the RESETB pin output goes from high to low in the case of the VDFL type ICs.

### <RESETB / RESET Pin Output Signal>

\* VDFL (RESETB) type - output signal: Low when detected.

The RESETB pin output goes from high to low whenever the VIN pin voltage falls below the detect voltage. The RESETB pin remains low for the release delay time (tDR) after the VIN pin voltage reaches the release voltage. If neither rising nor falling signals are applied to the WD pin within the watchdog timeout period, the RESETB pin output remains low for the release delay time (tDR), and thereafter the RESET pin outputs high level signal.

### <Hysteresis>

When the internal comparator output is high, the NMOS transistor connected in parallel to R3 is turned ON, activating the hysteresis circuit. The difference between the release and detect voltages represents the hysteresis width, as shown by the following calculations:

$$V_{DFL} \text{ (detect voltage)} = (R1+R2+R3) \times V_{ref} / (R2+R3)$$

$$V_{DR} \text{ (release voltage)} = (R1+R2) \times V_{ref} / (R2)$$

$$V_{HYS} \text{ (hysteresis width)} = V_{DR} - V_{DFL} \text{ (V)}$$

$$V_{DR} > V_{DFL}$$

\* Please refer to the block diagrams for R1, R2, R3 and Vref.

\* Hysteresis width is selectable from VDFL x 0.05V (TYP.).

### <Watchdog (WD) Pin>

The series use a watchdog timer to detect malfunction or “runaway” of the microprocessor. If neither rising nor falling signals are applied from the microprocessor within the watchdog timeout period, the RESETB pin output maintains the detection state for the release delay time (tDR), and thereafter the RESETB pin outputs low to high signal. The watchdog pin is pulled down to the VSS internally. When the watchdog pin is not connected, A reset signal comes out after the watchdog timeout period. Six watchdog timeout period settings (tWD) are available in 1.6s, 800ms, 400ms, 200ms, 100ms, and 50ms.

### <EN Pin>

In case where the watchdog function is not used, When the EN pin input driven to low level, only the watchdog function is forced off while the detect voltage circuit remains operation. For using the watchdog function, the EN pin should be used in high level. Even after the input voltage and the EN pin voltage are driven back high, the RESETB pin output maintains the detection state for the release delay time (tDR). (Refer to the TIMING CHART 1-①.) The watchdog function recovers immediately when the input voltage becomes higher than the release voltage and the EN pin voltage driven from low to high level. (Refer to the TIMING CHART 1-②.) A diode, which is an input protection element, is connected between the EN pin and VIN pin. Therefore, if the EN pin is applied voltage that exceeds VIN, the current will flow to VIN through the diode. For avoiding any damage to the IC, please use this IC within the stated maximum ratings (VSS -0.3 ~ VIN +0.3) on the EN pin.

### <ENB Pin>

In case where the watchdog function is not used, when the ENB pin input driven to high level, only the watchdog function is forced off while the detect voltage circuit remains operation. For using the watchdog function, the ENB pin should be used in low level. Even after the input voltage and the ENB pin voltage are driven back low, the RESETB pin output maintains the detection state for the release delay time (tDR). (Refer to the TIMING CHART 2-①.) The watchdog function recovers immediately when the input voltage becomes higher than the release voltage and the ENB pin voltage driven from high to low level. (Refer to the TIMING CHART 2-②.) A diode, which is an input protection element, is connected between the ENB pin and VIN pin. Therefore, if the ENB pin is applied voltage that exceeds VIN, the current will flow to VIN through the diode. For avoiding any damage to the IC, please use this IC within the stated maximum ratings (VSS -0.3 ~ VIN +0.3) on the ENB pin.

### <Release Delay Time>

Release delay time (tDR) is the time that elapses from when the VIN pin reaches the release voltage, or when the watchdog timeout period expires with no rising signal applied to the WD pin, until the RESETB pin output is released from the detection state. Five release delay time (tDR) watchdog timeout period settings are available in 400ms, 200ms, 100ms, 50ms, and 3.13ms.

### <Detect Delay Time>

Detect Delay Time (tDF) is the time that elapses from when the VIN pin voltage falls to the detect voltage until the RESETB pin output goes into the detection state.

**TIMING CHARTS**

1. XC6121/XC6122 Series (EN products)

● N-ch Open Drain Output (Rpull=100kΩ)

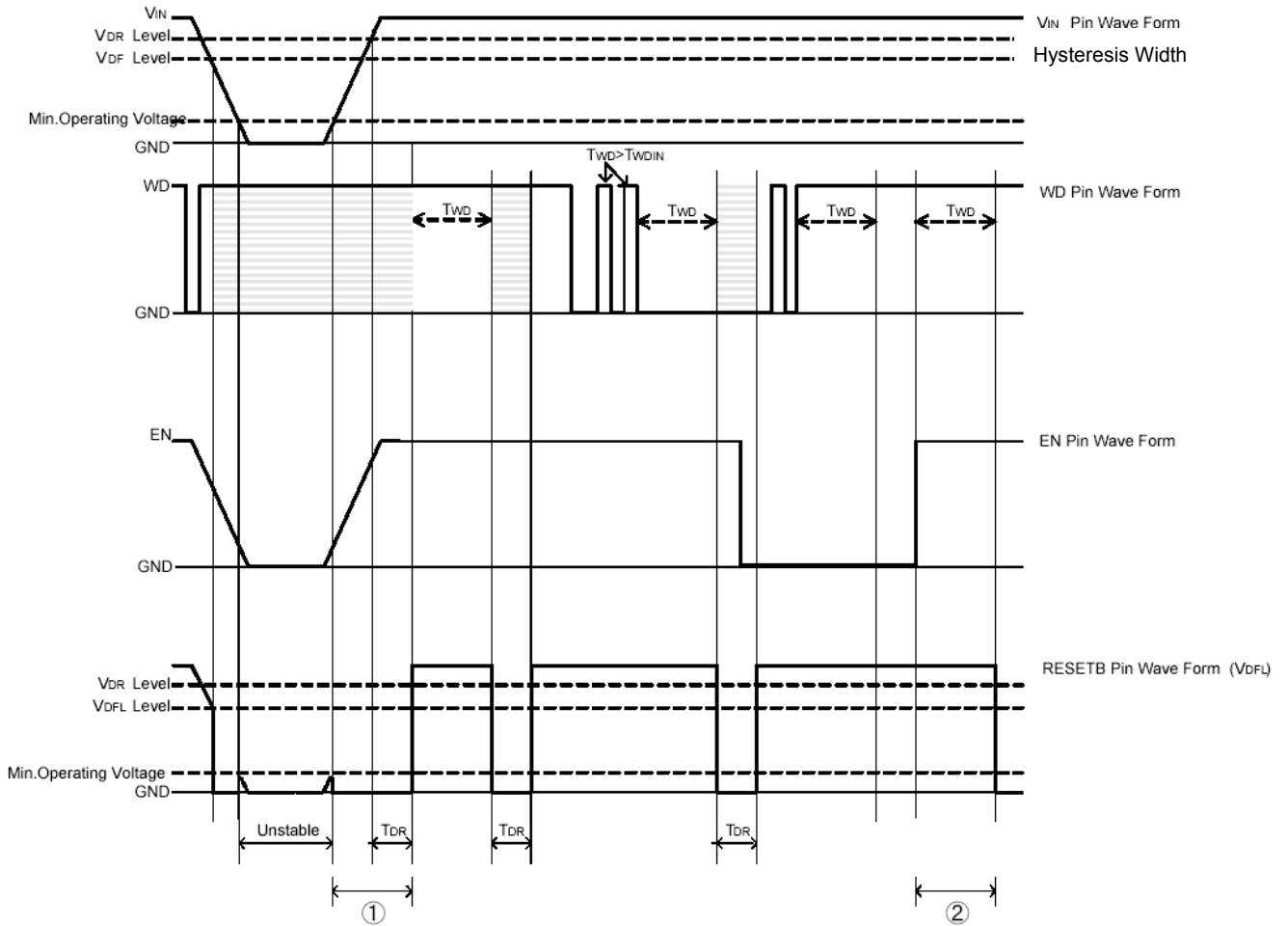

● t<sub>DF</sub> (N-ch Open Drain Output, R<sub>pull</sub>=100kΩ)



**TIMING CHARTS (Continued)**

2. XC6123/XC6124 Series (ENB products)

● N-ch Open Drain Output (Rpull=100kΩ)

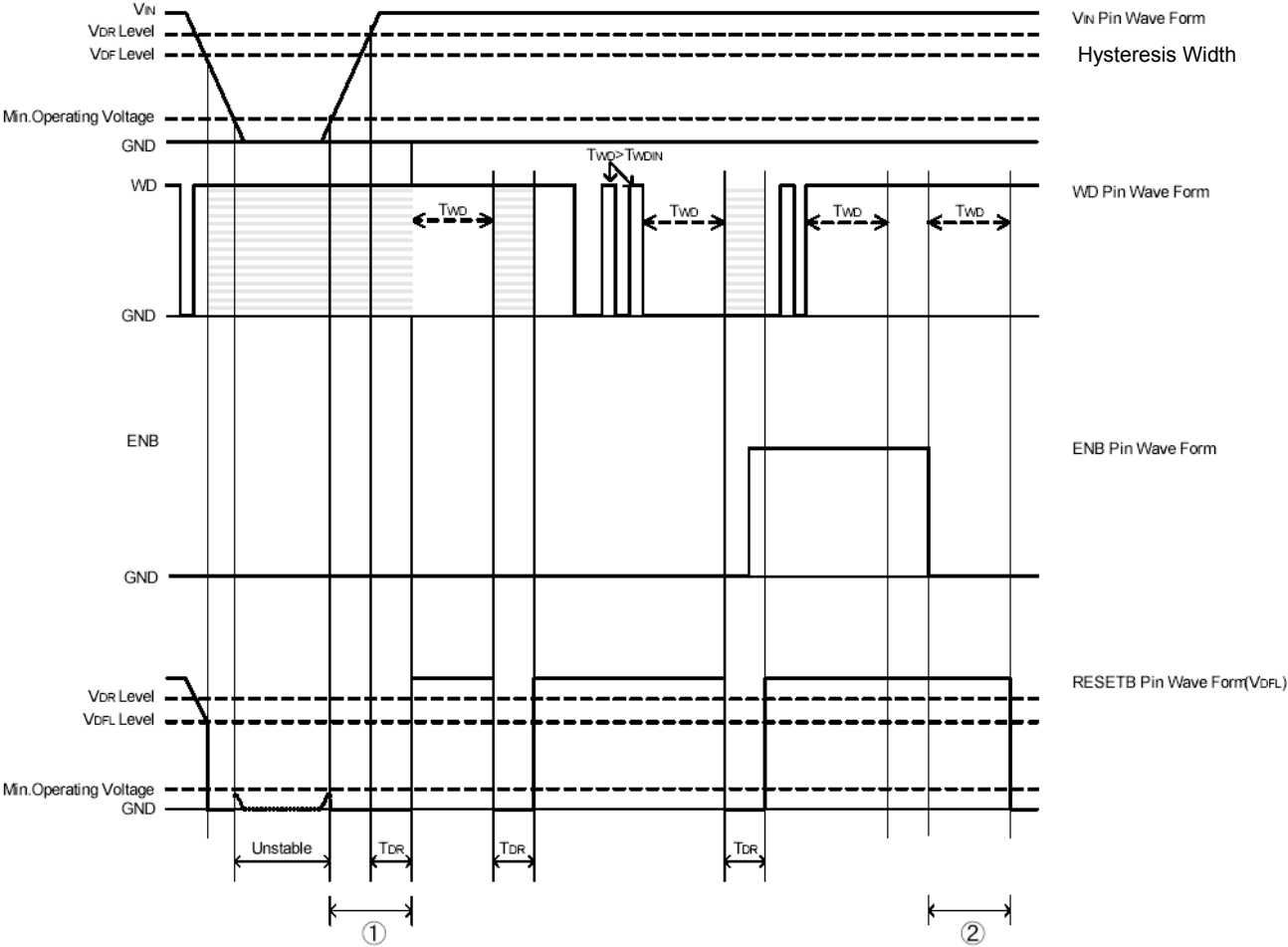

● t<sub>DF</sub> (N-ch Open Drain Output, Rpull=100kΩ)

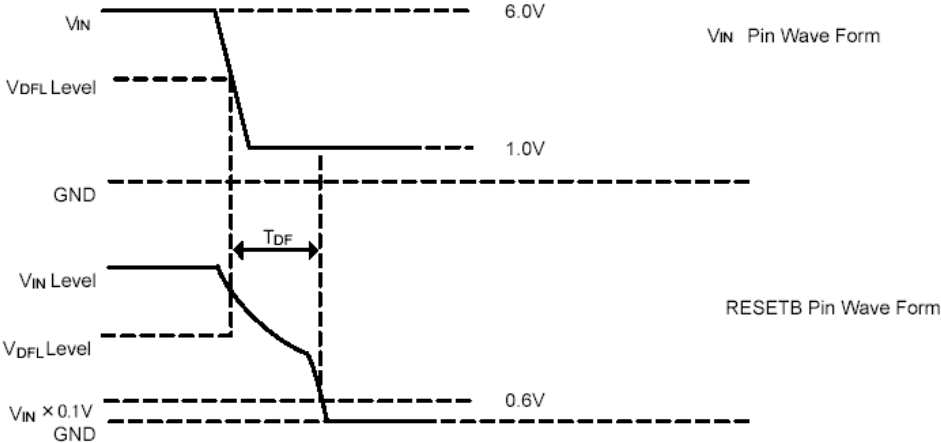

## NOTES ON USE

1. Please use this IC within the stated maximum ratings. For temporary, transitional voltage drop or voltage rising phenomenon, the IC is liable to malfunction should the ratings be exceeded.
2. When a resistor is connected between the  $V_{IN}$  pin and the input, the  $V_{IN}$  voltage drops while the IC is operating and a malfunction may occur as a result of the IC's through current.
3. In order to stabilize the IC's operations, please ensure that the  $V_{IN}$  pin's input frequency's rise and fall times are more than  $1 \mu s/V$ .
4. Noise at the power supply may cause a malfunction of the watchdog operation or the voltage detector. In such case, please strength  $V_{IN}$  and GND lines. Also, please connect a capacitor such as  $0.22 \mu F$  between the  $V_{IN}$  pin and the GND pin and evaluate the device on the actual board carefully before use.
5. Protecting against a malfunction while the watchdog time out period, an ignoring time (no reaction time) occurs to the rise and fall times. Referring to the figure below, the ignoring time (no reaction time) lasts for  $900 \mu s$  at maximum. (refer to the Figure1 below)
6. The EN pin of the XC6121 series is not internally pulled up. When using the watchdog function, please drive the  $V_{EN}$  pin in high level. The EN pin of the XC6122 series is internally pulled up. The watchdog function can be used even the EN pin left open. The ENB pin of the XC6123 series is not internally pulled down. When using the watchdog function, please drive the  $V_{ENB}$  pin in low level. The ENB pin of the XC6124 series is internally pulled up. The watchdog function can be used even the ENB pin left open.
7. Torex places an importance on improving our products and its reliability. However, by any possibility, we would request user fail-safe design and post-aging treatment on system or equipment.

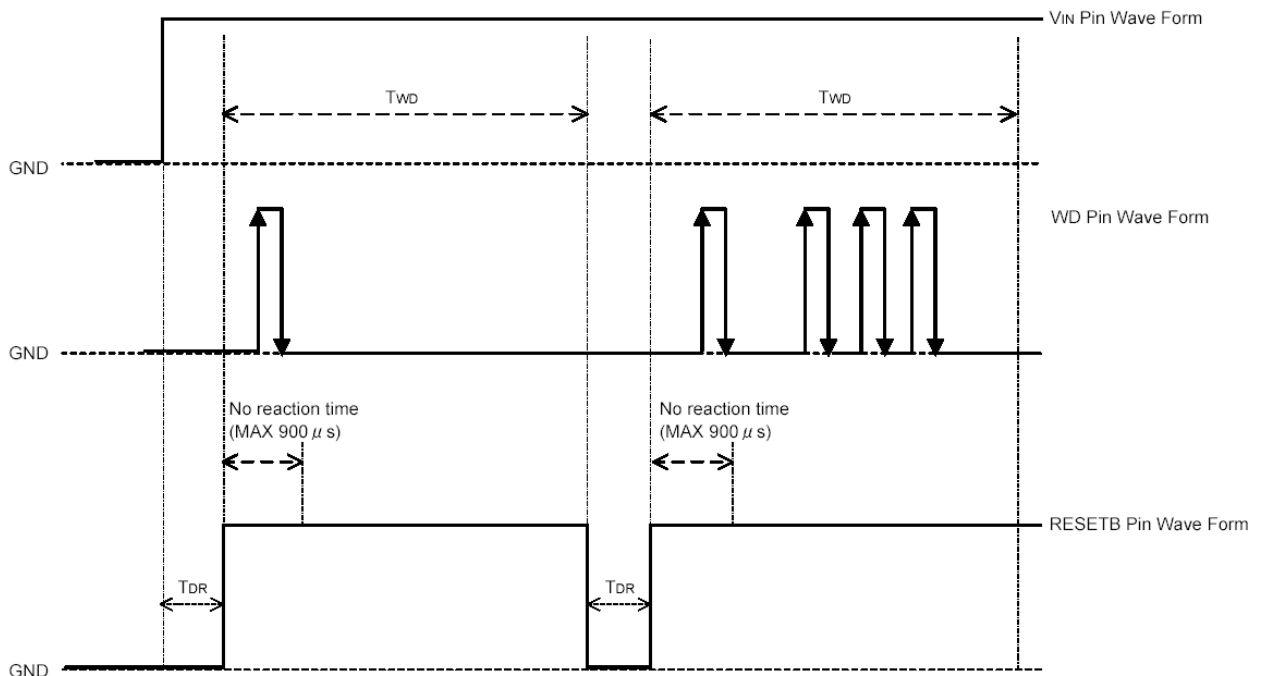

[Figure1]

## ■ PIN LOGIC CONDITIONS

| PIN NAME        | LOGIC | CONDITIONS                      | PIN NAME | LOGIC | CONDITIONS  |
|-----------------|-------|---------------------------------|----------|-------|---|
| V <sub>IN</sub> | H     | $V_{IN} \geq V_{DFL} + V_{HYS}$ | WD       | H     | The state maintaining $WD \geq V_{WDH}$ for more than $t_{WD}$    |
|                 | L     | $V_{IN} \leq V_{DFL}$           |          | L     | The state maintaining $WD \leq V_{WDL}$ for more than $t_{WD}$    |
| EN/ENB          | H     | $V_{EN}/V_{ENB} \geq 1.30V$     |          | L→H   | $V_{WDL} \rightarrow V_{WDH}$ , $300ns \leq t_{WDIN} \leq t_{WD}$ |
|                 | L     | $V_{EN}/V_{ENB} \leq 0.35V$     |          | H→L   | $V_{WDH} \rightarrow V_{WDL}$ , $300ns \leq t_{WDIN} \leq t_{WD}$ |

**NOTE:**

V<sub>DFL</sub>: Detect Voltage

V<sub>HYS</sub>: Hysteresis Range

V<sub>WDH</sub>: WD High Level Voltage

V<sub>WDL</sub>: WD Low Level Voltage

t<sub>WDIN</sub>: WD Pulse Width

t<sub>WD</sub>: WD Timeout Period

For the details of each parameter, please see the electrical characteristics.

## ■ FUNCTION CHART

| V <sub>IN</sub> | XC6121/XC6122   | XC6123/XC6124    | V <sub>WD</sub> | V <sub>RESETB</sub> <sup>(*)2</sup>  |
|-----------------|-----------------|------------------|-----------------|--------------------------------------|
|                 | V <sub>EN</sub> | V <sub>ENB</sub> |                 |                                      |
| H               | H               | L                | H               | Repeating detect and release (H→L→H) |
|                 |                 |                  | L               |                                      |
|                 |                 |                  | OPEN            |                                      |
|                 |                 |                  | L↔H             |                                      |
| H               | L               | H                | *1              | H                                    |
| L               |                 | L                |                 | L                                    |

**NOTE:**

\*1: Including all logics of the WD (V<sub>WD</sub>=H, L, OPEN, H→L, L→H).

\*2: When the V<sub>RESETB</sub> is High, the circuit is in the release state.

When the V<sub>RESETB</sub> is Low, the circuit is in the detection state.

\*3: V<sub>IN</sub>=L and V<sub>EN</sub>/V<sub>ENB</sub>=H can not be combined because the rated input voltage of the EN/ENB pin is V<sub>SS</sub>-0.3V to V<sub>IN</sub>+0.3V.

\*4: The RESETB pin becomes indefinite operation while  $0.35V < V_{EN}/V_{ENB} < 1.3V$ .

\*5: The EN pin of the XC6121 series is not internally pulled up. When using the watchdog function, please drive the V<sub>EN</sub> pin in high level. The EN pin of the XC6122 series is internally pulled up. The watchdog function can be used even the EN pin left open. The ENB pin of the XC6123 series is not internally pulled down. When using the watchdog function, please drive the V<sub>ENB</sub> pin in low level. The ENB pin of the XC6124 series is internally pulled up. The watchdog function can be used even the ENB pin left open.

## TEST CIRCUITS

Circuit ①



Circuit ②

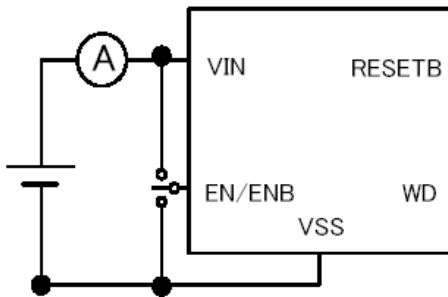

Circuit ③

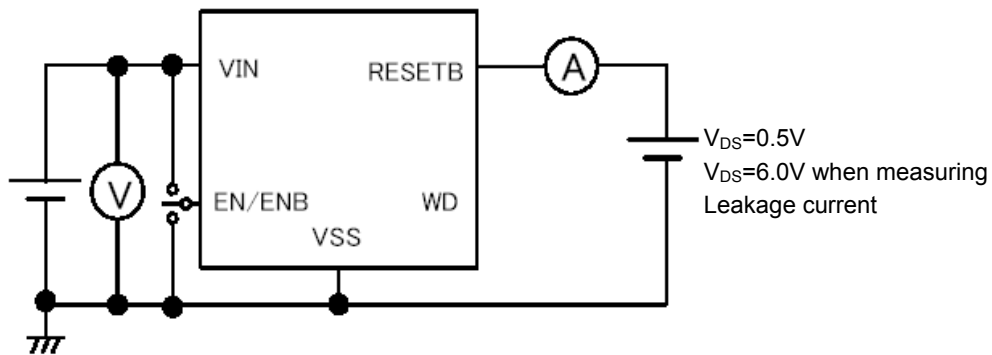

■ TEST CIRCUITS (Continued)

Circuit ④

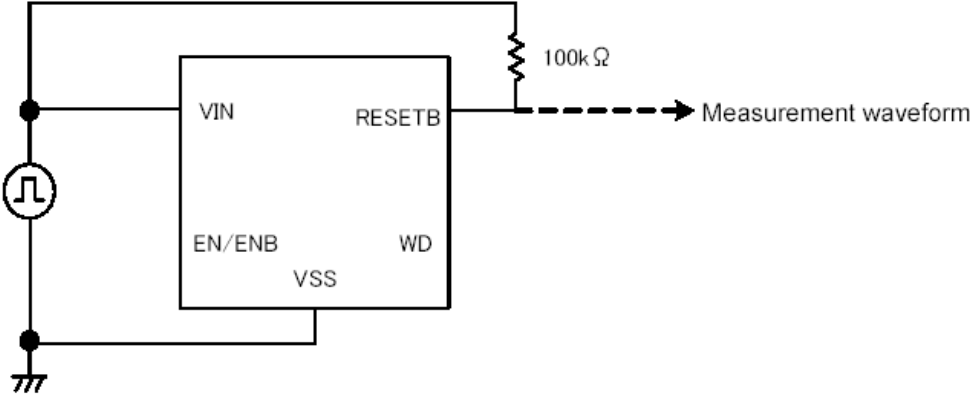

Circuit ⑤

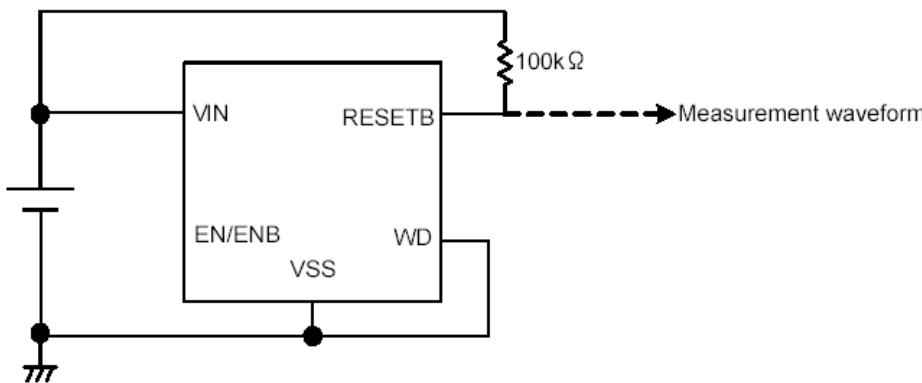

Circuit ⑥

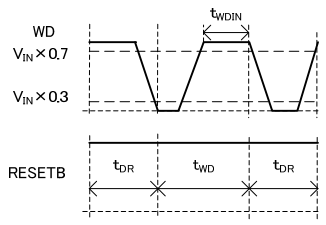
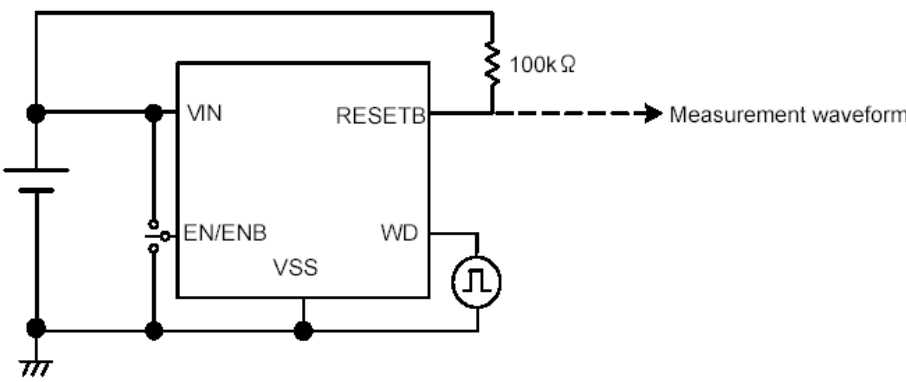

TEST CIRCUITS (Continued)

Circuit ⑦

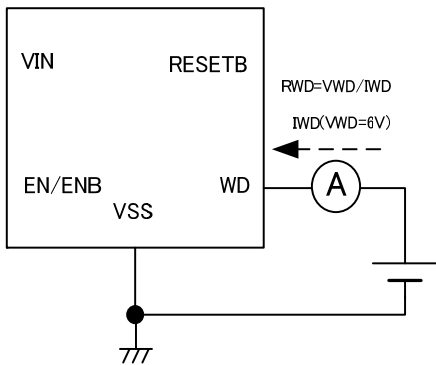

Circuit ⑧

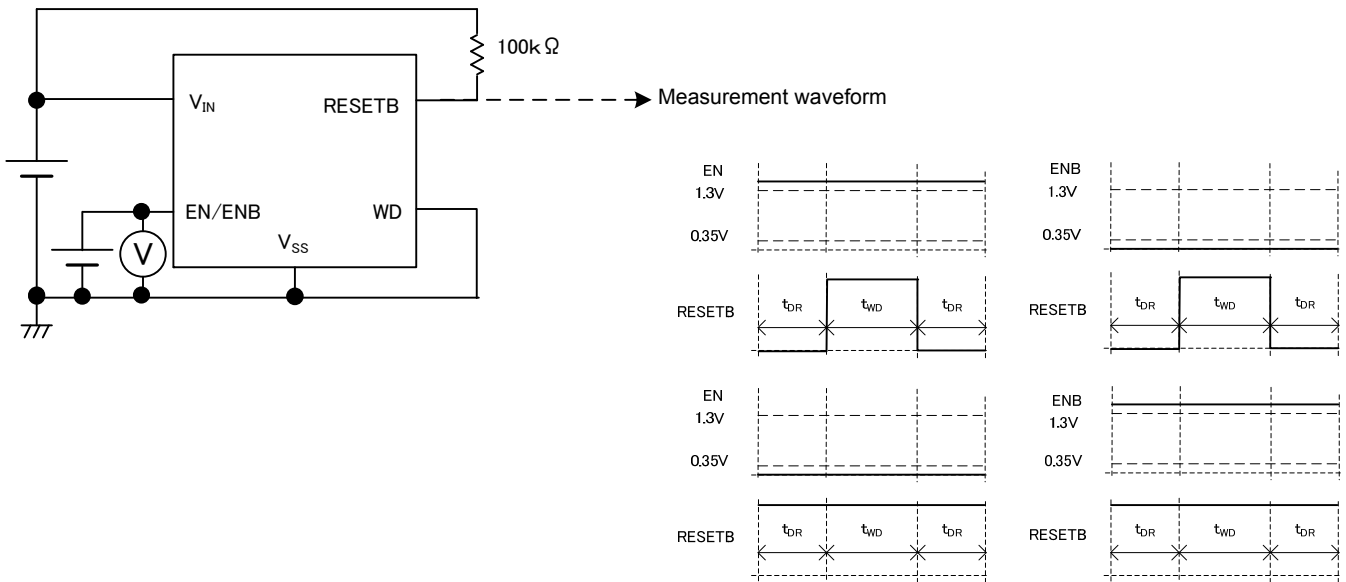

Note: The above reference is about the EN/ENB logic operation.

Circuit ⑨

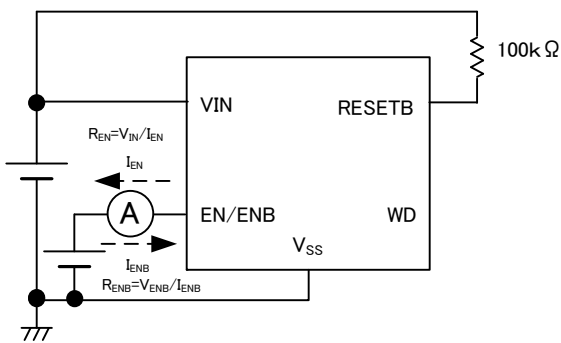

Note:  
XC6122 series has EN pin,  
XC6124 Series has ENB pin.



**TYPICAL PERFORMANCE CHARACTERISTICS**

(1.) Supply Current vs. Input Voltage

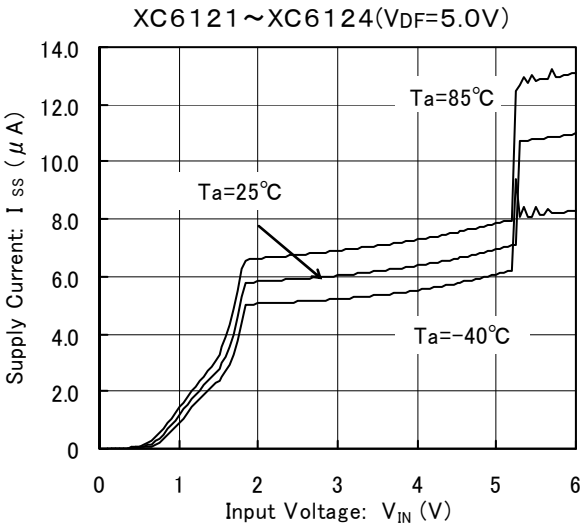
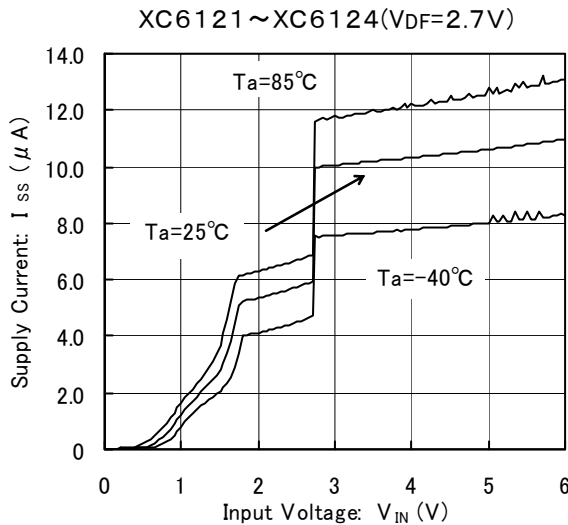
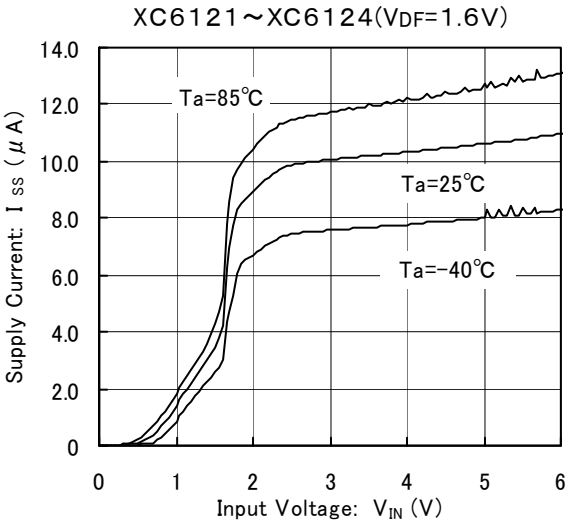

(2.) Detect, Release Voltage vs. Ambient Temperature

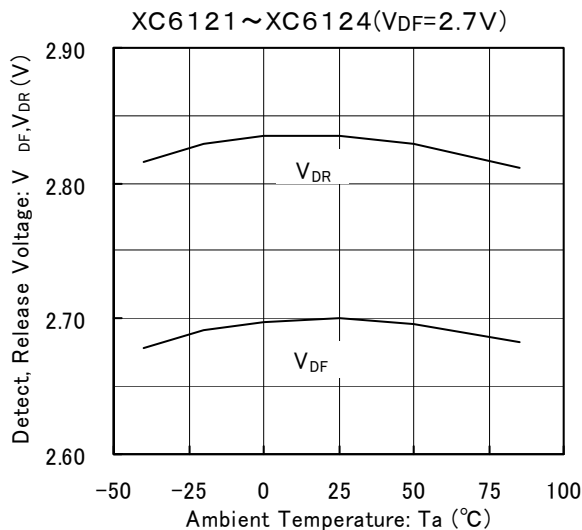
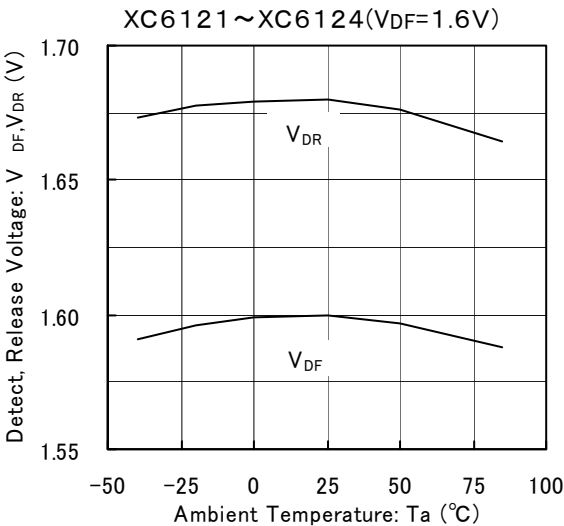

**TYPICAL PERFORMANCE CHARACTERISTICS (Continued)**

(2.) Detect, Release Voltage vs. Ambient Temperature (Continued)

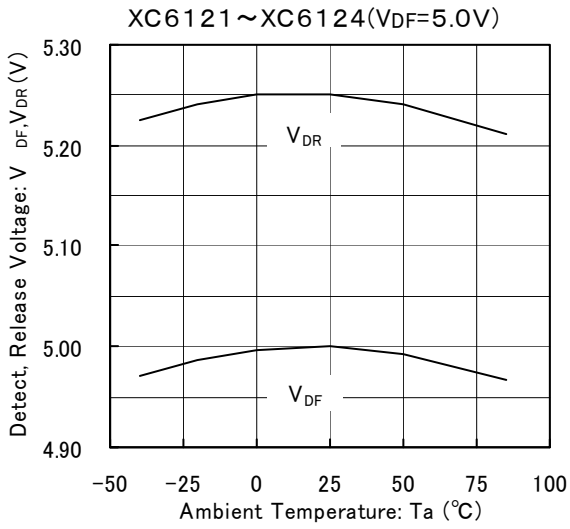

(3.) Nch Driver Output Current vs. V<sub>DS</sub>

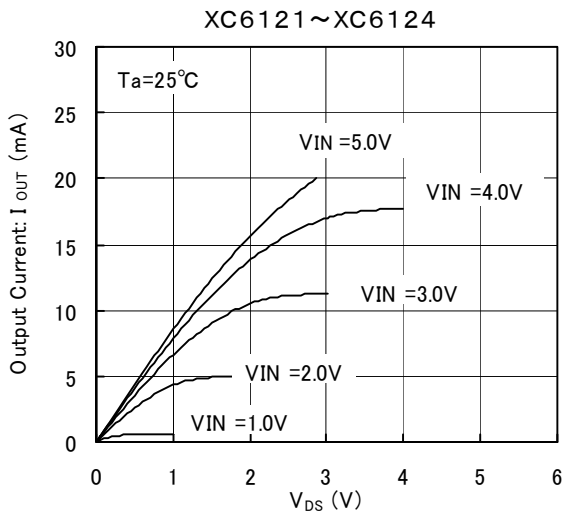

(4.) Driver Output Current vs. Input Voltage

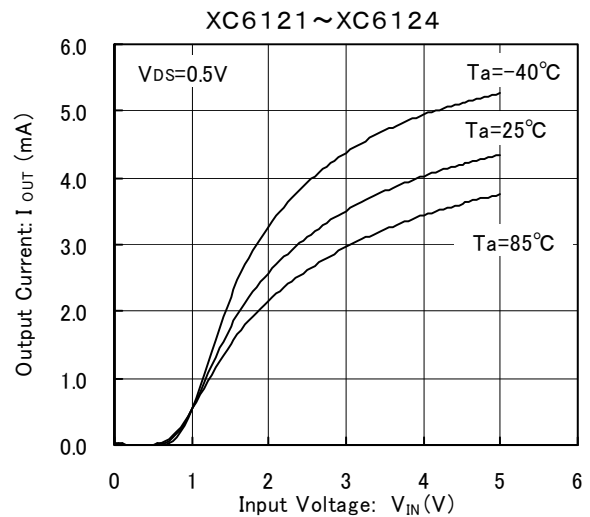

(5.) Release Delay Time vs. Ambient Temperature

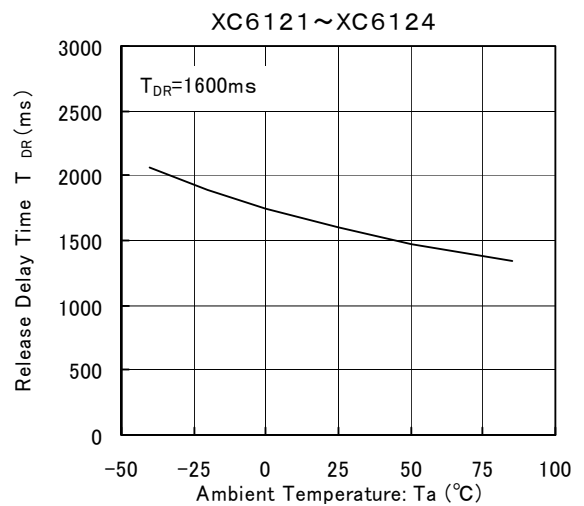
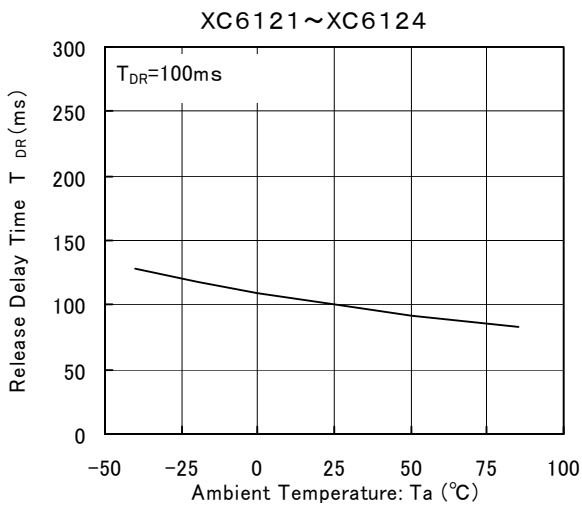

**■ TYPICAL PERFORMANCE CHARACTERISTICS (Continued)**

(6.) Watchdog Timeout Period vs. Ambient Temperature

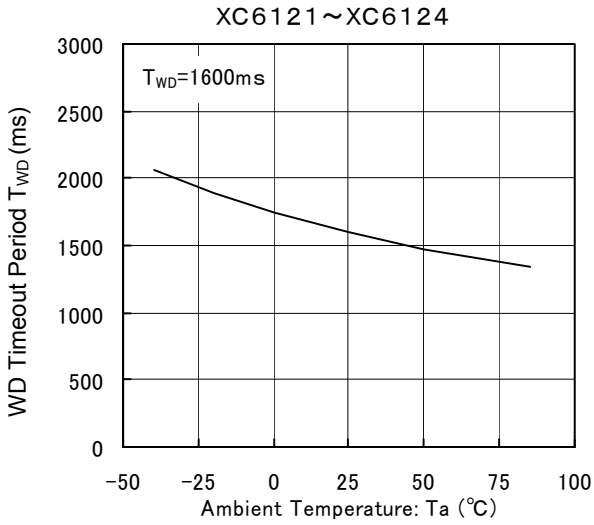
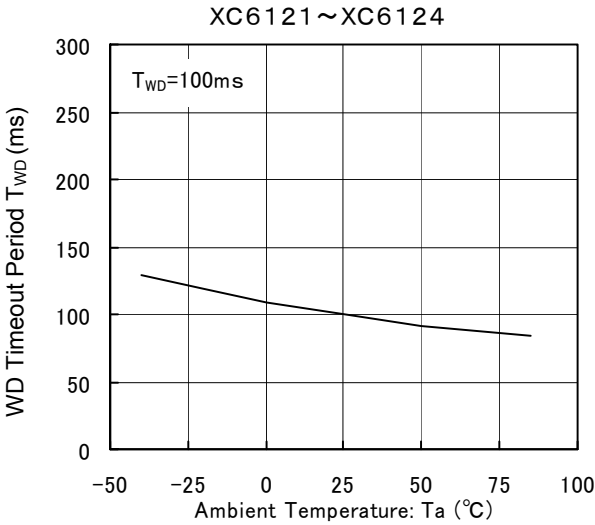

(7.) Release Delay Time vs. Input Voltage

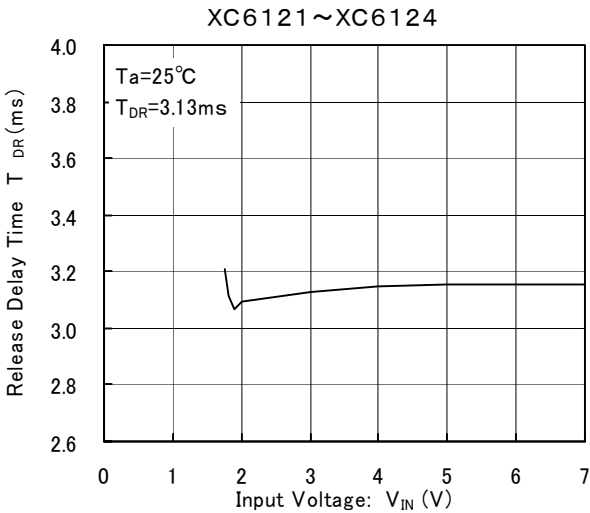

(8.) Watchdog Timeout Period vs. Input Voltage

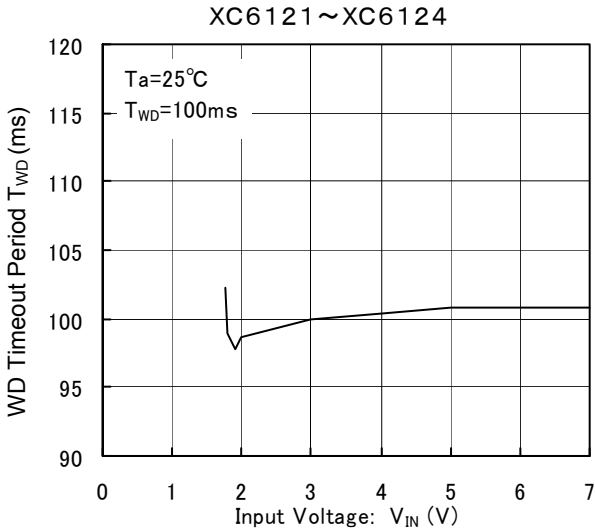

(9.) Watchdog Low Level Threshold vs. Ambient Temperature

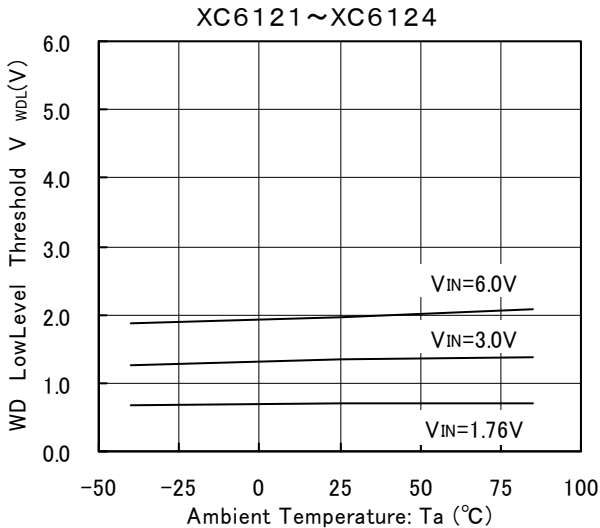

(10.) Watchdog High Level Threshold vs. Ambient Temperature

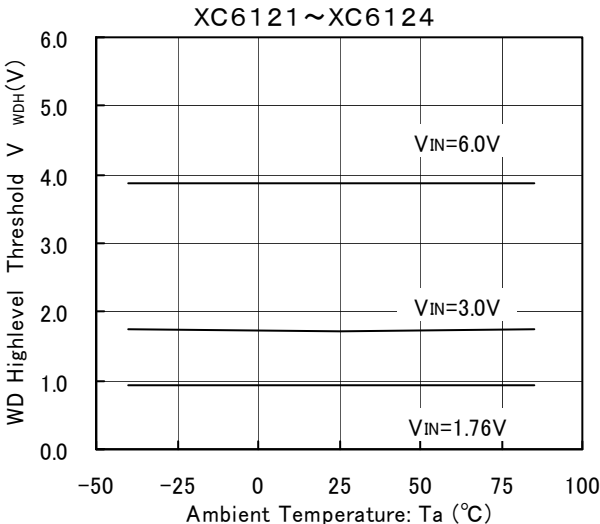

**TYPICAL PERFORMANCE CHARACTERISTICS (Continued)**

(11.) Watchdog Pull-Down Resistance vs. Ambient Temperature

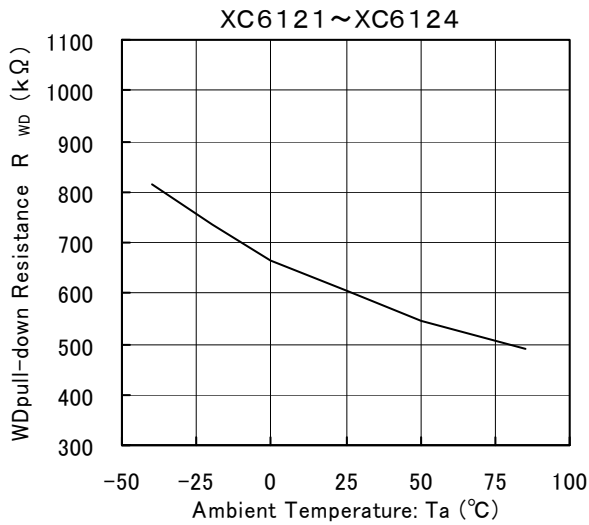

(12.) EN Pull-Up Resistance vs. Ambient Temperature

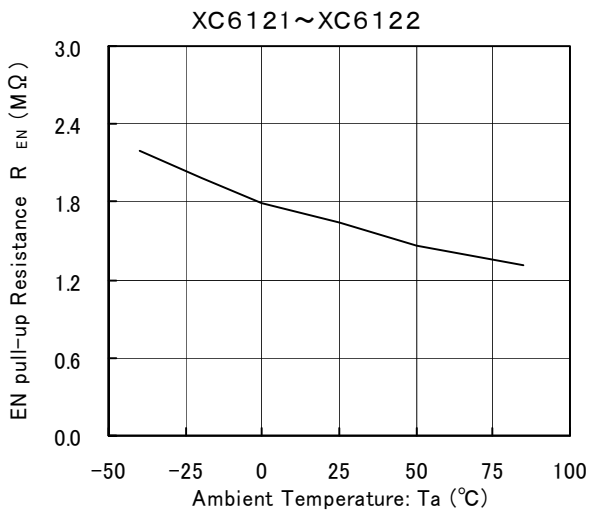

(13.) ENB Pull-Down Resistance vs. Ambient Temperature

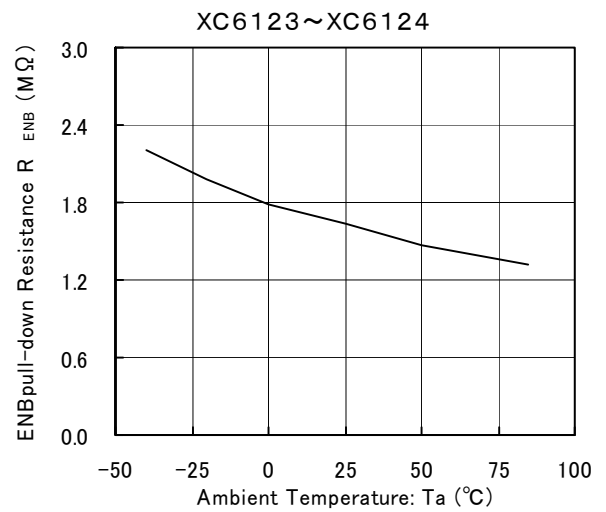

(14.) EN Low Level Voltage vs. Ambient Temperature

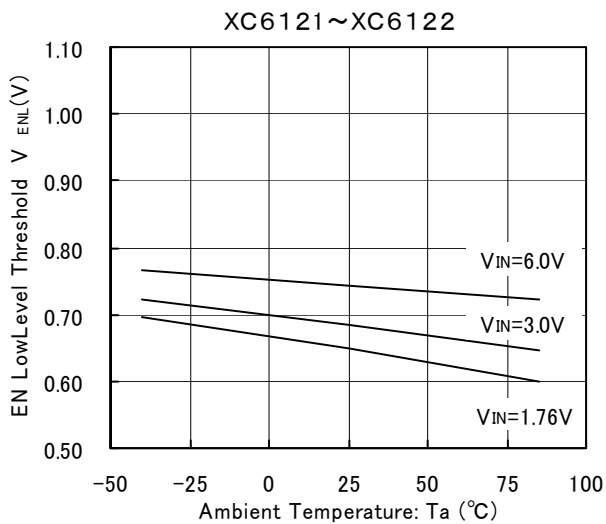

(15.) EN High Level Voltage vs. Ambient Temperature

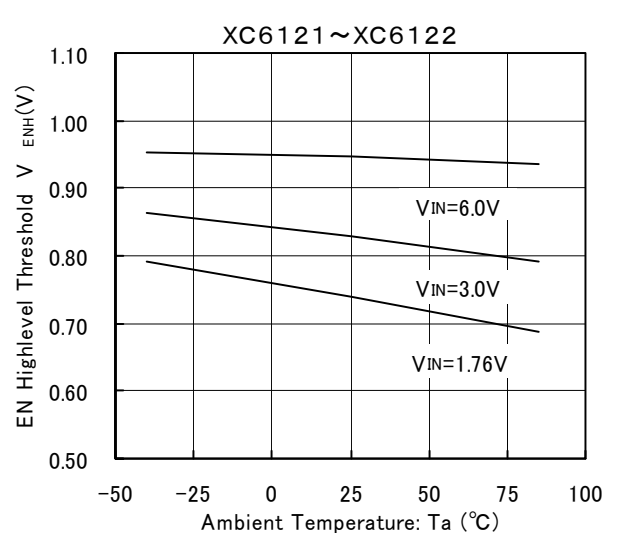

■ TYPICAL PERFORMANCE CHARACTERISTICS (Continued)

(16.) ENB Low Level Voltage vs. Ambient Temperature

(17.) ENB High Level Voltage vs. Ambient Temperature

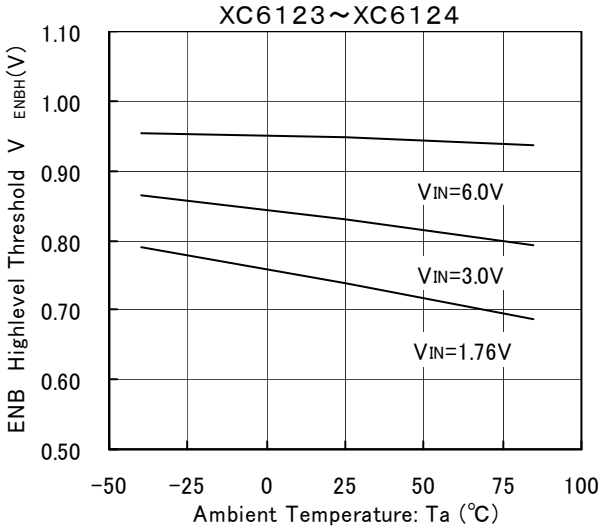
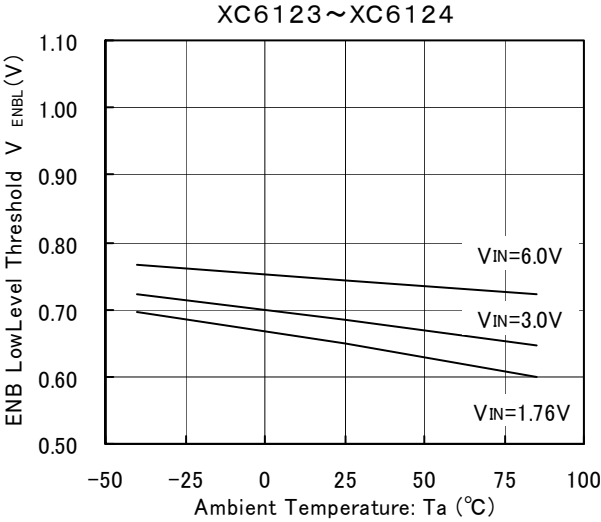

PACKAGING INFORMATION

●SOT-25

Unit :mm

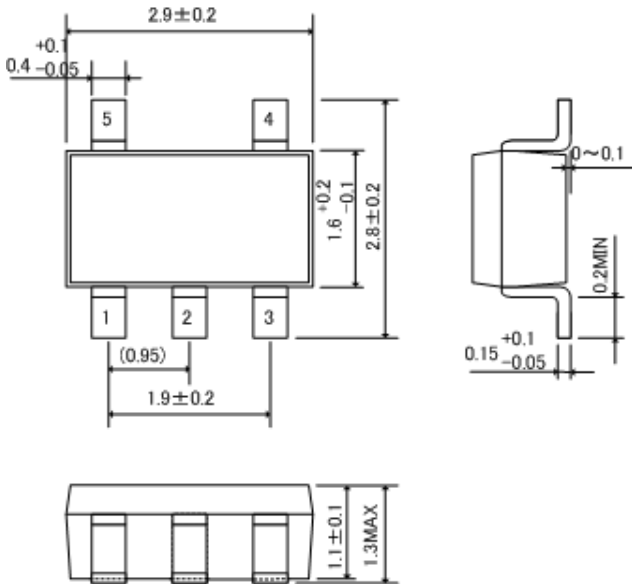

●USP-6C

Unit :mm

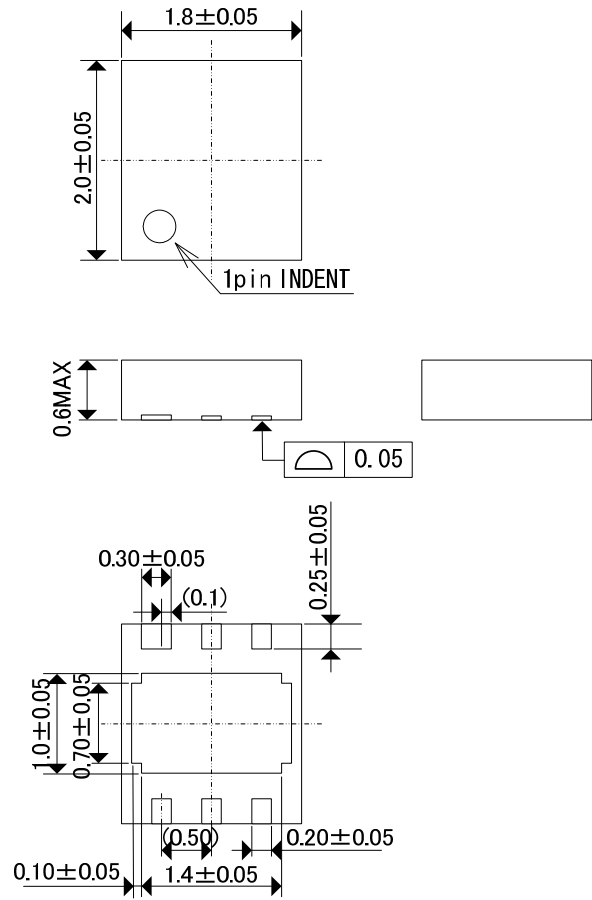

●USP-6C Reference Pattern Layout

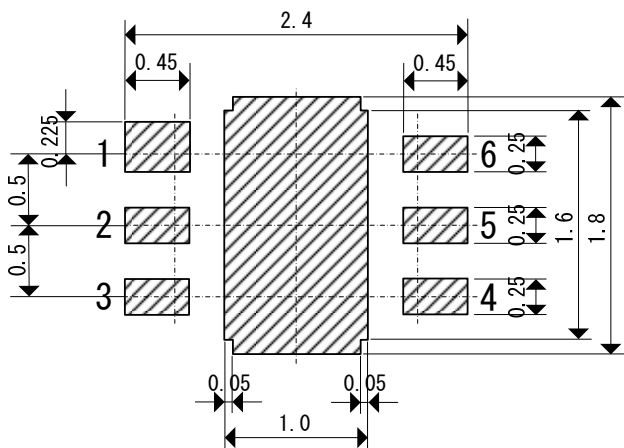

●USP-6C Reference Metal Mask Design

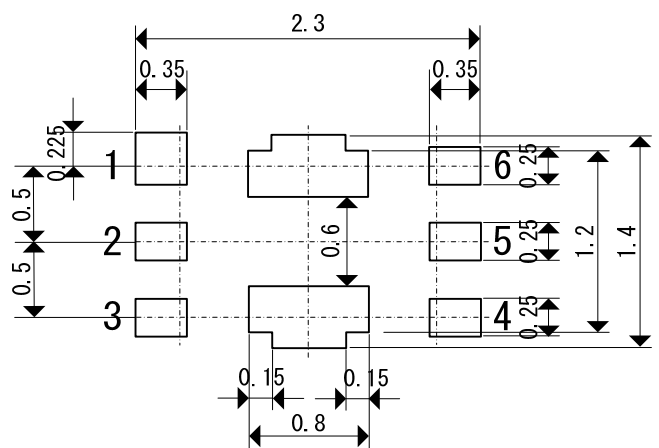

## MARKING RULE

① represents product series

| MARK     | PRODUCT SERIES |
|----------|----------------|
| <u>E</u> | XC6121*****    |
| <u>F</u> | XC6122*****    |
| <u>H</u> | XC6123*****    |
| <u>K</u> | XC6124*****    |

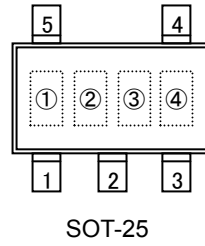

② represents release delay time and watchdog timeout period

XC6121Series

| MARK | RELEASE DELAY TIME | WATCH DOG TIMEOUT PERIOD | PRODUCT SERIES |
|------|--------------------|--------------------------|----------------|
| 0    | 3.13ms             | 50ms                     | XC6121A2****   |
| 1    | 3.13 ms            | 100ms                    | XC6121A3****   |
| 2    | 3.13 ms            | 200ms                    | XC6121A4****   |
| 3    | 3.13 ms            | 400ms                    | XC6121A5****   |
| 4    | 3.13 ms            | 800ms                    | XC6121A7****   |
| 5    | 3.13 ms            | 1.6s                     | XC6121A6****   |
| 6    | 50ms               | 50ms                     | XC6121C2****   |
| 7    | 50ms               | 100ms                    | XC6121C3****   |
| 8    | 50ms               | 200ms                    | XC6121C4****   |
| 9    | 50ms               | 400ms                    | XC6121C5****   |
| A    | 50ms               | 800ms                    | XC6121C7****   |
| B    | 50ms               | 1.6s                     | XC6121C6****   |
| H    | 100ms              | 100ms                    | XC6121D3****   |
| C    | 100ms              | 200ms                    | XC6121D4****   |
| L    | 100ms              | 400ms                    | XC6121D5****   |
| D    | 100ms              | 800ms                    | XC6121D7****   |
| M    | 100ms              | 1.6s                     | XC6121D6****   |
| E    | 200ms              | 200ms                    | XC6121E4****   |
| R    | 200ms              | 400ms                    | XC6121E5****   |
| F    | 200ms              | 800ms                    | XC6121E7****   |
| S    | 200ms              | 1.6s                     | XC6121E6****   |
| T    | 400ms              | 400ms                    | XC6121F5****   |
| K    | 400ms              | 800ms                    | XC6121F7****   |
| U    | 400ms              | 1.6s                     | XC6121F6****   |

XC6122/XC6123/XC6124Series

| MARK     | RELEASE DELAY TIME | WATCH DOG TIMEOUT PERIOD | PRODUCT SERIES |
|----------|--------------------|--------------------------|----------------|
| N        | 3.13ms             | 50ms                     | XC612*A2****   |
| P        | 3.13ms             | 100ms                    | XC612*A3****   |
| R        | 3.13ms             | 200ms                    | XC612*A4****   |
| S        | 3.13ms             | 400ms                    | XC612*A5****   |
| T        | 3.13ms             | 800ms                    | XC612*A7****   |
| U        | 3.13ms             | 1.6s                     | XC612*A6****   |
| V        | 50ms               | 50ms                     | XC612*C2****   |
| X        | 50ms               | 100ms                    | XC612*C3****   |
| Y        | 50ms               | 200ms                    | XC612*C4****   |
| Z        | 50ms               | 400ms                    | XC612*C5****   |
| <u>A</u> | 50ms               | 800ms                    | XC612*C7****   |
| <u>B</u> | 50ms               | 1.6s                     | XC612*C6****   |
| <u>A</u> | 100ms              | 100ms                    | XC612*D3****   |
| <u>C</u> | 100ms              | 200ms                    | XC612*D4****   |
| B        | 100ms              | 400ms                    | XC612*D5****   |
| <u>D</u> | 100ms              | 800ms                    | XC612*D7****   |
| C        | 100ms              | 1.6s                     | XC612*D6****   |
| D        | 200ms              | 200ms                    | XC612*E4****   |
| E        | 200ms              | 400ms                    | XC612*E5****   |
| H        | 200ms              | 800ms                    | XC612*E7****   |
| F        | 200ms              | 1.6s                     | XC612*E6****   |
| K        | 400ms              | 400ms                    | XC612*F5****   |
| M        | 400ms              | 800ms                    | XC612*F7****   |
| L        | 400ms              | 1.6s                     | XC612*F6****   |

## MARKING RULE (Continued)

③ represents detect voltage

XC6121 Series

| MARK     | DETECT VOLTAGE (V) | PRODUCT SERIES |
|----------|--------------------|----------------|
| F        | 1.6                | XC6121**16**   |
| H        | 1.7                | XC6121**17**   |
| K        | 1.8                | XC6121**18**   |
| L        | 1.9                | XC6121**19**   |
| M        | 2.0                | XC6121**20**   |
| N        | 2.1                | XC6121**21**   |
| P        | 2.2                | XC6121**22**   |
| R        | 2.3                | XC6121**23**   |
| S        | 2.4                | XC6121**24**   |
| T        | 2.5                | XC6121**25**   |
| U        | 2.6                | XC6121**26**   |
| V        | 2.7                | XC6121**27**   |
| X        | 2.8                | XC6121**28**   |
| Y        | 2.9                | XC6121**29**   |
| Z        | 3.0                | XC6121**30**   |
| <u>0</u> | 3.1                | XC6121**31**   |
| <u>1</u> | 3.2                | XC6121**32**   |
| <u>2</u> | 3.3                | XC6121**33**   |
| <u>3</u> | 3.4                | XC6121**34**   |
| <u>4</u> | 3.5                | XC6121**35**   |
| <u>5</u> | 3.6                | XC6121**36**   |
| <u>6</u> | 3.7                | XC6121**37**   |
| <u>7</u> | 3.8                | XC6121**38**   |
| <u>8</u> | 3.9                | XC6121**39**   |
| <u>9</u> | 4.0                | XC6121**40**   |
| <u>A</u> | 4.1                | XC6121**41**   |
| <u>B</u> | 4.2                | XC6121**42**   |
| <u>C</u> | 4.3                | XC6121**43**   |
| <u>D</u> | 4.4                | XC6121**44**   |
| <u>E</u> | 4.5                | XC6121**45**   |
| <u>F</u> | 4.6                | XC6121**46**   |
| <u>H</u> | 4.7                | XC6121**47**   |
| <u>K</u> | 4.8                | XC6121**48**   |
| <u>L</u> | 4.9                | XC6121**49**   |
| <u>M</u> | 5.0                | XC6121**50**   |

XC6122/XC6123/XC6124 Series

| MARK     | DETECT VOLTAGE (V) | PRODUCT SERIES |
|----------|--------------------|----------------|
| H        | 1.6                | XC612***16**   |
| K        | 1.7                | XC612***17**   |
| L        | 1.8                | XC612***18**   |
| M        | 1.9                | XC612***19**   |
| N        | 2.0                | XC612***20**   |
| P        | 2.1                | XC612***21**   |
| R        | 2.2                | XC612***22**   |
| S        | 2.3                | XC612***23**   |
| T        | 2.4                | XC612***24**   |
| U        | 2.5                | XC612***25**   |
| V        | 2.6                | XC612***26**   |
| X        | 2.7                | XC612***27**   |
| Y        | 2.8                | XC612***28**   |
| Z        | 2.9                | XC612***29**   |
| <u>0</u> | 3.0                | XC612***30**   |
| <u>1</u> | 3.1                | XC612***31**   |
| <u>2</u> | 3.2                | XC612***32**   |
| <u>3</u> | 3.3                | XC612***33**   |
| <u>4</u> | 3.4                | XC612***34**   |
| <u>5</u> | 3.5                | XC612***35**   |
| <u>6</u> | 3.6                | XC612***36**   |
| <u>7</u> | 3.7                | XC612***37**   |
| <u>8</u> | 3.8                | XC612***38**   |
| <u>9</u> | 3.9                | XC612***39**   |
| <u>A</u> | 4.0                | XC612***40**   |
| <u>B</u> | 4.1                | XC612***41**   |
| <u>C</u> | 4.2                | XC612***42**   |
| <u>D</u> | 4.3                | XC612***43**   |
| <u>E</u> | 4.4                | XC612***44**   |
| <u>F</u> | 4.5                | XC612***45**   |
| <u>H</u> | 4.6                | XC612***46**   |
| <u>K</u> | 4.7                | XC612***47**   |
| <u>L</u> | 4.8                | XC612***48**   |
| <u>M</u> | 4.9                | XC612***49**   |
| <u>N</u> | 5.0                | XC612***50**   |

④ represents production lot number

0 to 9 and A to Z and inverted 0 to 9 and A to Z repeated. (G, I, J, O, Q, W excluded.)



## ■ MARKING RULE (Continued)

① represents product series

| MARK | PRODUCT SERIES |
|------|----------------|
| P    | XC6121*****    |
| K    | XC6122*****    |
| R    | XC6123*****    |
| U    | XC6124*****    |

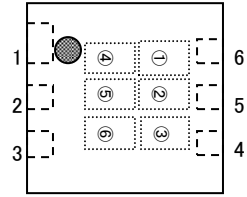

USP-6C

② represents release delay time

| MARK | RELEASE DELAY TIME | PRODUCT SERIES |
|------|--------------------|----------------|
| A    | 3.13ms             | XC612*A****    |
| C    | 50ms               | XC612*C****    |
| D    | 100ms              | XC612*D****    |
| E    | 200ms              | XC612*E****    |
| F    | 400ms              | XC612*F****    |

③ represents watchdog timeout period

| MARK | WATCHDOG TIMEOUT PERIOD | PRODUCT SERIES |
|------|-------------------------|----------------|
| 2    | 50ms                    | XC612*2*****   |
| 3    | 100ms                   | XC612*3*****   |
| 4    | 200ms                   | XC612*4*****   |
| 5    | 400ms                   | XC612*5*****   |
| 7    | 800ms                   | XC612*7*****   |
| 6    | 1.6s                    | XC612*6*****   |

④⑤ represents detect voltage

| MARK |   | DETECT VOLTAGE (V) | PRODUCT SERIES |
|------|---|--------------------|----------------|
| ④    | ⑤ |                    |                |
| 3    | 3 | 3.3                | XC612***33**   |
| 5    | 0 | 5.0                | XC612***50**   |

⑥ represents production lot number

0 to 9 and A to Z repeated. (G, I, J, O, Q, W excluded.)

\*No character inversion used.

1. The products and product specifications contained herein are subject to change without notice to improve performance characteristics. Consult us, or our representatives before use, to confirm that the information in this datasheet is up to date.
2. We assume no responsibility for any infringement of patents, patent rights, or other rights arising from the use of any information and circuitry in this datasheet.
3. Please ensure suitable shipping controls (including fail-safe designs and aging protection) are in force for equipment employing products listed in this datasheet.
4. The products in this datasheet are not developed, designed, or approved for use with such equipment whose failure or malfunction can be reasonably expected to directly endanger the life of, or cause significant injury to, the user.  
(e.g. Atomic energy; aerospace; transport; combustion and associated safety equipment thereof.)
5. Please use the products listed in this datasheet within the specified ranges.  
Should you wish to use the products under conditions exceeding the specifications, please consult us or our representatives.
6. We assume no responsibility for damage or loss due to abnormal use.
7. All rights reserved. No part of this datasheet may be copied or reproduced without the prior permission of TOREX SEMICONDUCTOR LTD.

**TOREX SEMICONDUCTOR LTD.**