

## Charge Pump Voltage Inverter IC

## ■ GENERAL DESCRIPTION

The XC6351A series are charge pump voltage inverter ICs that have 4 MOSFETs built in. Since highly efficient negative voltages can be generated with only 2 external capacitors connected, GaAs bias power supplies & OpAmp's negative power supplies etc., can be easily accommodated on a standard PCB.

A mini-molded, 6 pin, SOT-26 and USP-6B packages provides for space saving and makes high density mounting possible.

Low power consumption and high efficiency make this series perfect for use with battery operated applications.

Since the IC's operations stop when output is shutdown via the CE (chip enable) function, total power consumption reduction is possible in applications which use this IC.

## ■ APPLICATIONS

- Cellular and portable phones
- Miniature LCD panels
- Palmtop computers, PDAs
- Various battery powered systems

## ■ FEATURES

- Operating Voltage Range** : 1.2V ~ 5.0V
- Oscillation Frequency** : 120kHz  
: 35kHz ( custom )
- Low Supply Current** : 310  $\mu$  A ( TYP. )  
100  $\mu$  A  
(35kHz custom TYP.)
- High Efficiency** : 90% (TYP.) (  $R_L = 2k\Omega$  )
- Stand-by Current** : 2.0  $\mu$  A (MAX.)
- CE(Chip Enable) Function**
- Packages** : SOT-26 ,USP-6B
- Environmentally Friendly** : EU RoHS Compliant, Pb Free

## ■ TYPICAL APPLICATION CIRCUIT

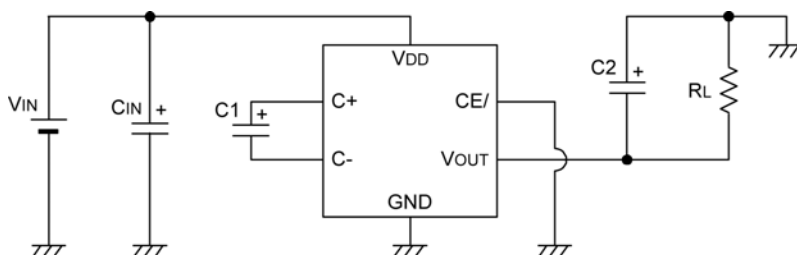

## ■ TYPICAL PERFORMANCE CHARACTERISTICS

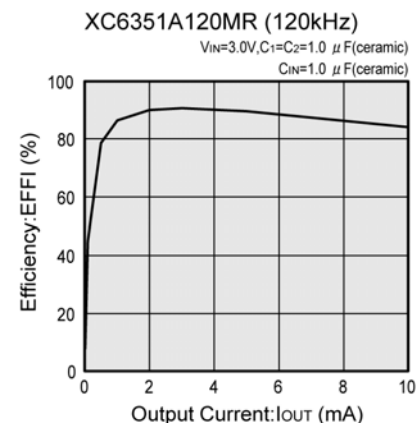

## ■ PIN CONFIGURATION

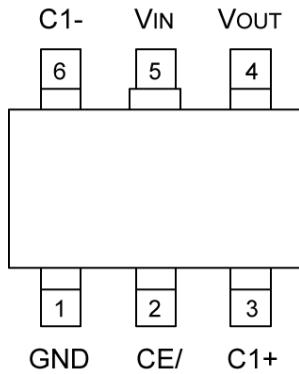

SOT-26  
(TOP VIEW)

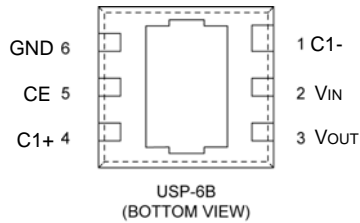

\*The dissipation pad for the USP-6B package should be solder-plated in recommended mount pattern and metal masking so as to enhance mounting strength and heat release. If the pad needs to be connected to other pins, it should be connected to the VIN pin.

## ■ PIN ASSIGNMENT

PIN NUMBER		SYMBOL	FUNCTION
SOT-26	USP-6B		
1	6	GND	Ground
2	5	CE/	Chip Enable (Low Active)
3	4	C1+	External Capacitor +Pin
4	3	VOUT	Reverse Output
5	2	VIN	Power Supply
6	1	C1-	External Capacitor -Pin

## ■ PRODUCT CLASSIFICATION

### ● Ordering Information

XC6351A ①②③④⑤-⑥<sup>(\*)</sup>

DESIGNATOR	DESCRIPTION	SYMBOL	DESCRIPTION
①②③	Oscillation Frequency	120	120kHz
		035	35kHz (custom)
④⑤-⑥	Packages Taping Type <sup>(*)</sup>	MR	SOT-26
		MR-G	SOT-26
		DR	USP-6B
		DR-G	USP-6B

<sup>(\*)</sup> The "-G" suffix indicates that the products are Halogen and Antimony free as well as being fully RoHS compliant.

<sup>(\*)</sup> The device orientation is fixed in its embossed tape pocket. For reverse orientation, please contact your local Torex sales office or representative. (Standard orientation: ④R-⑥, Reverse orientation: ④L-⑥)

## ■ BLOCK DIAGRAM

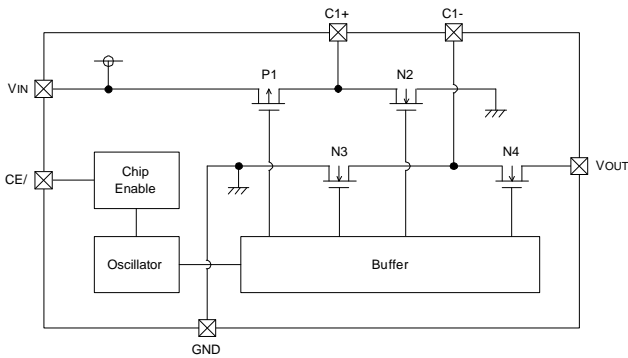

**Note:**

1. In operation, the following conditions will be repeated alternately:  
P1 & N3 ON: N2 & N4 OFF  
P1 & N3 OFF: N2 & N4 ON
2. In standby mode, P1, N3 & N4 will be ON and N2 will be OFF.  
The output pin VOUT will be connected to GND.

## ■ ABSOLUTE MAXIMUM RATINGS

Ta = 25°C

PARAMETER	SYMBOL	RATINGS	UNITS
VIN Input Voltage	VIN	6.0	V
VOUT Pin Voltage	VOUT	-6~0.3	V
C1+ Pin Voltage	C1+	-0.3~VIN + 0.3	V
C1- Pin Voltage	C1-	VOUT - 0.3~0.3	V
CE/ Pin Voltage	CE/	-0.3~VIN + 0.3	V
IOUT Pin Current	IOUT	50	mA
Power Dissipation	SOT-26	Pd	mW
	USP-6B		
Operating Temperature Range	Topr	-30~+80	°C
Storage Temperature Range	Tstg	-40~+125	°C

Note: Voltage is all ground standardized.

## ELECTRICAL CHARACTERISTICS

FOSC=120kHz, Ta=25°C

PARAMETER	SYMBOL	CONDITIONS	MIN.	TYP.	MAX.	UNITS	CIRCUIT
Supply Current	I <sub>DD</sub>		-	310	520	μA	1
Operating Voltage Range	V <sub>IN</sub>	R <sub>L</sub> =5kΩ	1.2	-	5.0	V	2
Oscillation Frequency	FOSC		75	120	192	kHz	1
Power Transition Efficiency	EFFI	R <sub>L</sub> =2kΩ	-	90	-	%	2
Voltage Transition Efficiency	VEFFI	R <sub>L</sub> =∞	95	-	-	%	2
Output Impedance	R <sub>OUT</sub>	R <sub>L</sub> =5kΩ	-	45	90	Ω	2
Stand -by Current	I <sub>STB</sub>	CE/=V <sub>IN</sub>	-	-	2.0	μA	3
CE/ 'H' Level Voltage	V <sub>CEH</sub>		0.9	-	-	V	3
CE/ 'L' Level Voltage	V <sub>CEL</sub>		-	-	0.25	V	3

Measuring Conditions: Unless otherwise stated, V<sub>IN</sub> = 5.0V, CE/ = 0V

## TYPICAL APPLICATION CIRCUIT

### ● Standard Circuit

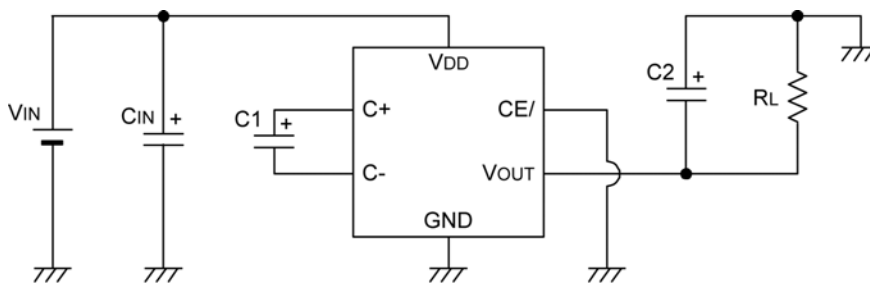

External components:

C<sub>IN</sub> = 1 μF (ceramic capacitor)

C<sub>1</sub> = C<sub>2</sub> = 1 μF (ceramic capacitor)\*

\* With the custom 35kHz frequency, C<sub>1</sub> = C<sub>2</sub> = 3.3 μF

## NOTES ON USE

1. Please use the IC & external components: within the specified electrical characteristics range and ensure that absolute maximum ratings are not exceeded.
2. For C<sub>1</sub> & C<sub>2</sub>, please use a capacitor with as small an ESR value as possible.
3. In order to reduce impedance between the IC's input pin and the power supply, we recommend that a capacitor (C<sub>IN</sub>) be connected to the input side.
4. If an external power supply is applied to the output pin in order to have V<sub>OUT</sub> connected to GND during standby, large current flows through the IC are a possibility. Further, do not use a capacitor at C<sub>2</sub> that has a large capacitance value.

## TEST CIRCUITS

Circuit 1

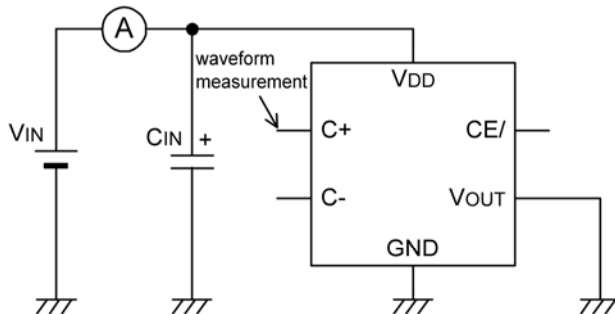

Circuit 2

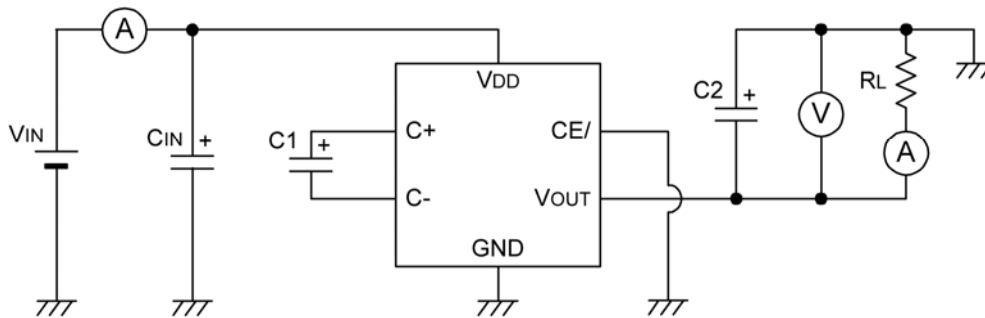

Circuit 3

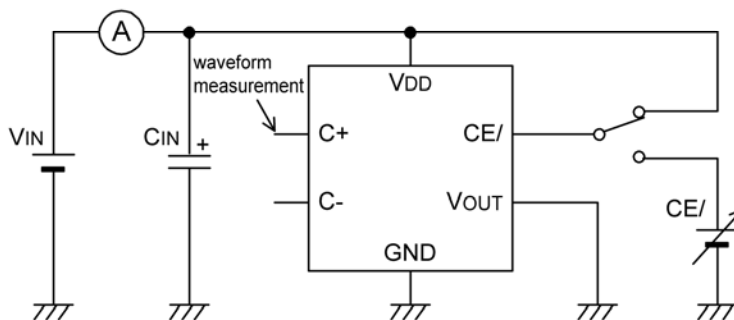

External components:

$C_{IN} = 1 \mu F$  (ceramic capacitor)

$C_1 = C_2 = 1 \mu F$  (ceramic capacitor)\*

\* With the custom 35kHz frequency,  $C_1 = C_2 = 3.3 \mu F$

## TYPICAL PERFORMANCE CHARACTERISTICS

(1) Output Voltage vs. Output Current

XC6351A120MR (120kHz)

$V_{IN}=5.0V, C_1=C_2=1.0 \mu F(\text{ceramic})$   
 $C_{IN}=1.0 \mu F(\text{ceramic})$

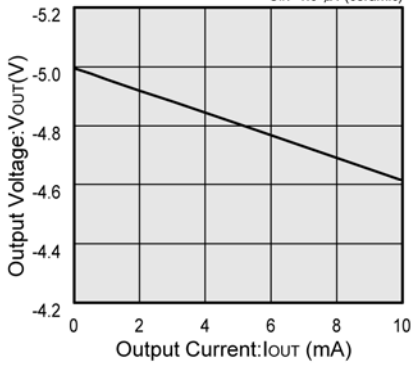

XC6351A120MR (120kHz)

$V_{IN}=3.0V, C_1=C_2=1.0 \mu F(\text{ceramic})$   
 $C_{IN}=1.0 \mu F(\text{ceramic})$

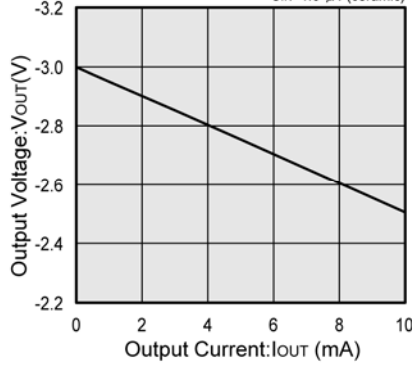

XC6351A120MR (120kHz)

$V_{IN}=2.0V, C_1=C_2=1.0 \mu F(\text{ceramic})$   
 $C_{IN}=1.0 \mu F(\text{ceramic})$

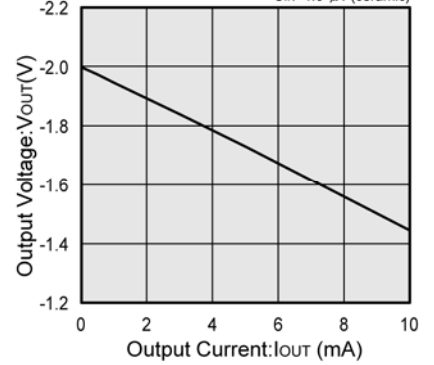

(2) Efficiency vs. Output Current

XC6351A120MR (120kHz)

$V_{IN}=5.0V, C_1=C_2=1.0 \mu F(\text{ceramic})$   
 $C_{IN}=1.0 \mu F(\text{ceramic})$

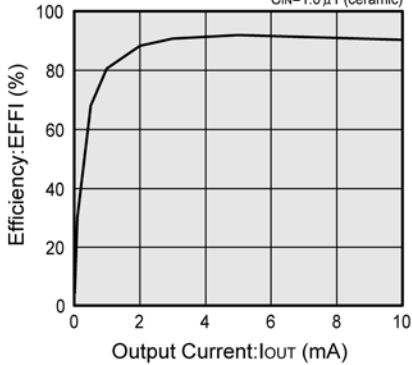

XC6351A120MR (120kHz)

$V_{IN}=3.0V, C_1=C_2=1.0 \mu F(\text{ceramic})$   
 $C_{IN}=1.0 \mu F(\text{ceramic})$

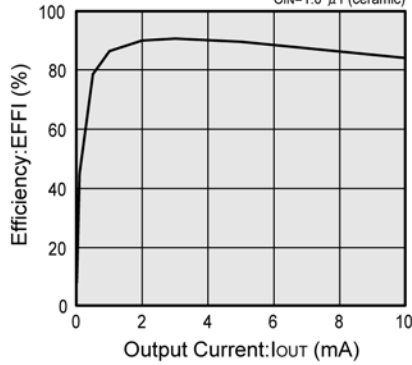

XC6351A120MR (120kHz)

$V_{IN}=2.0V, C_1=C_2=1.0 \mu F(\text{ceramic})$   
 $C_{IN}=1.0 \mu F(\text{ceramic})$

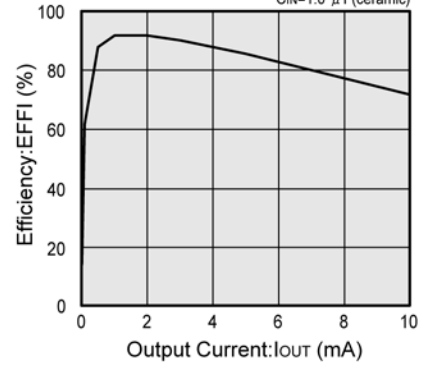

(3) Oscillation Frequency vs. Ambient Temperature

XC6351A120MR (120kHz)

$V_{IN}=5.0V, C_1=C_2=1.0 \mu F(\text{ceramic})$   
 $C_{IN}=1.0 \mu F(\text{ceramic})$

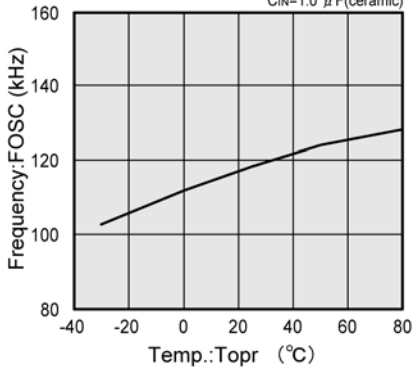

(4) Oscillation Frequency vs. Input Voltage

XC6351A120MR (120kHz)

$C_1=C_2=1.0 \mu F(\text{ceramic}), T_{opr}=25 (C)$   
 $C_{IN}=1.0 \mu F(\text{ceramic})$

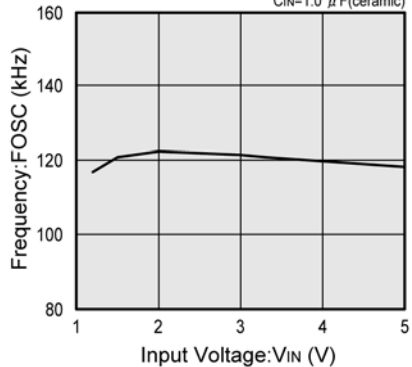

## PACKAGING INFORMATION

### ●SOT-26

Unit : mm

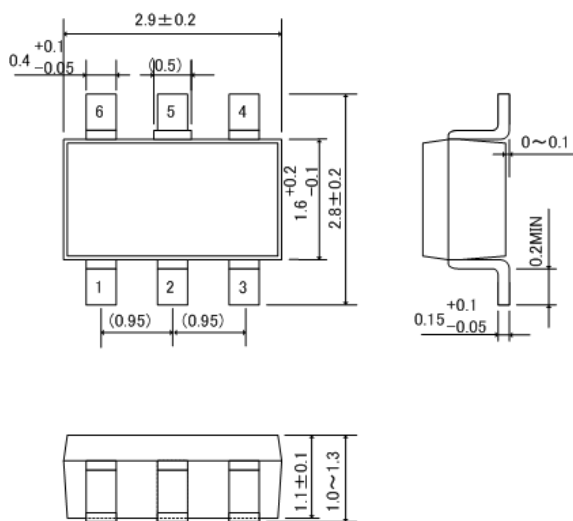

### ●USP-6B

Unit : mm

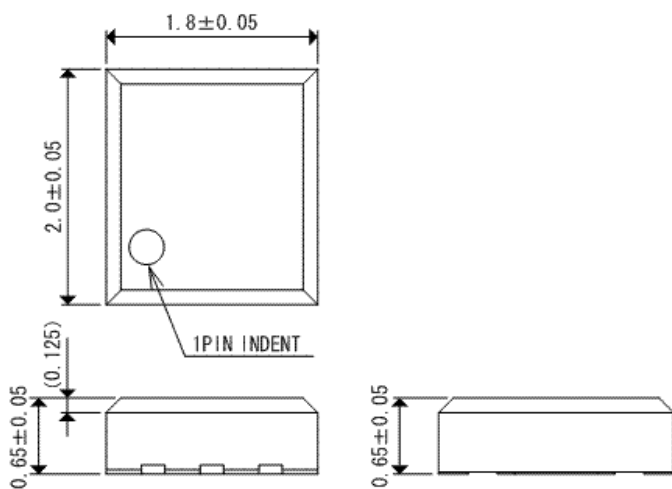

### ●USP-6B Reference Pattern Layout

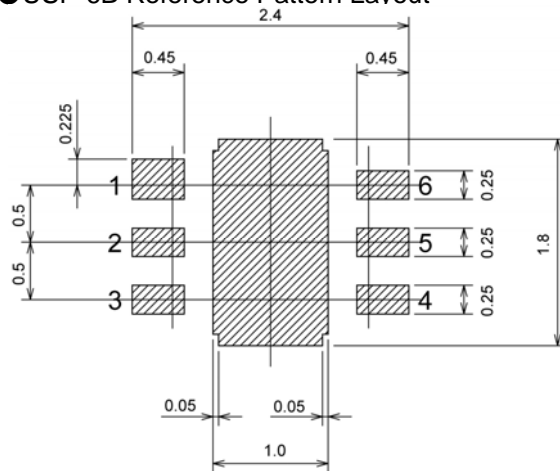

### ●USP-6B Reference Metal Mask Design

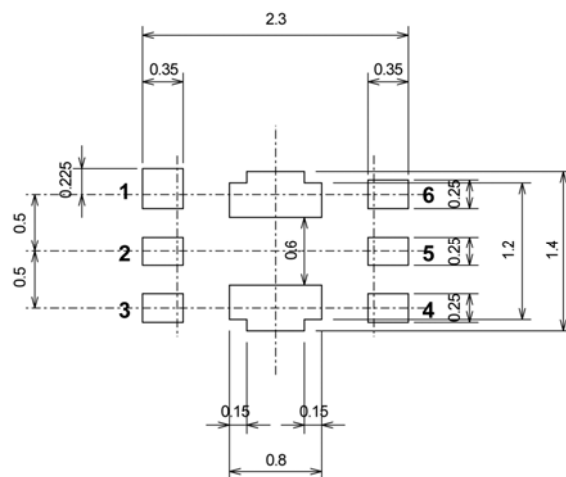
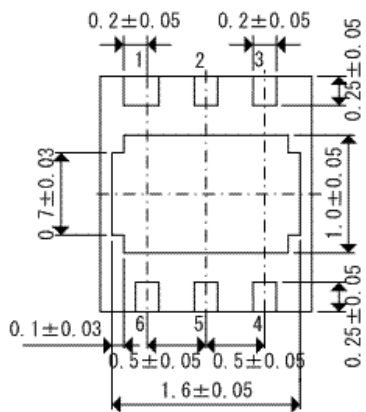

## MARKING RULE

### ● SOT-26

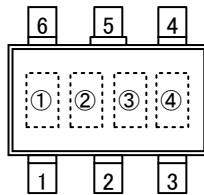

SOT-26  
(TOP VIEW)

① represents product series

MARK		PRODUCT SERIES
A		XC6351AxxxMx

②,③ represents oscillation frequency

MARK		OSCILLATION FREQUENCY	PRODUCT SERIES
②	③		
0	3	35kHz	XC6351A035Mx
1	2	120kHz	XC6351A120Mx

④ represents production lot number

0 to 9, A to Z repeated (G, I, J, O, Q, W excluded)

### ● USP-6B

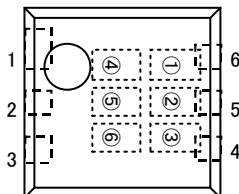

USP-6B  
(TOP VIEW)

①,②,③ represents product series

MARK			PRODUCT SERIES
①	②	③	
5	1	A	XC6351AxxxDx

④,⑤ represents oscillation frequency

MARK		OSCILLATION FREQUENCY	PRODUCT SERIES
④	⑤		
0	3	35kHz	XC6351A035Dx
1	2	120kHz	XC6351A120Dx

⑥ represents production lot number

0 to 9, A to Z repeated (G, I, J, O, Q, W excluded)

Note: No character inversion used.



1. The products and product specifications contained herein are subject to change without notice to improve performance characteristics. Consult us, or our representatives before use, to confirm that the information in this datasheet is up to date.
2. We assume no responsibility for any infringement of patents, patent rights, or other rights arising from the use of any information and circuitry in this datasheet.
3. Please ensure suitable shipping controls (including fail-safe designs and aging protection) are in force for equipment employing products listed in this datasheet.
4. The products in this datasheet are not developed, designed, or approved for use with such equipment whose failure or malfunction can be reasonably expected to directly endanger the life of, or cause significant injury to, the user.  
(e.g. Atomic energy; aerospace; transport; combustion and associated safety equipment thereof.)
5. Please use the products listed in this datasheet within the specified ranges.  
Should you wish to use the products under conditions exceeding the specifications, please consult us or our representatives.
6. We assume no responsibility for damage or loss due to abnormal use.
7. All rights reserved. No part of this datasheet may be copied or reproduced without the prior permission of TOREX SEMICONDUCTOR LTD.

**TOREX SEMICONDUCTOR LTD.**