

## Low Power Consumption Hall IC (Magnetic Sensor)

### GENERAL DESCRIPTION

The XC3202B series is a Hall effect magnetic sensor IC with a built-in CMOS output driver. The device features low power consumption and small packaging which is ideally suited for battery powered portable applications such as mobile phones, electronic dictionaries and handheld game consoles. When the magnetic flux density is higher than the operating point (Bop), the Low level signal is output. The High level signal is output when the magnetic flux density is lower than the release point (Brp).

### APPLICATIONS

- Cover detectors
- Mobile phones
- Electronic dictionaries
- Portable game consoles
- Home electronics (refrigerators, washing machines etc)

### FEATURES

Supply Voltage Range	: 2.4~5.5V
Average Supply Current	: 8 $\mu$ A
Operating Point	: South Pole 3mT(TYP.) North Pole -3mT(TYP.)
Release point	: South Pole 2mT(TYP.) North Pole -2mT(TYP.)
Hysteresis Width	: South Pole 1mT(TYP.) North Pole 1mT(TYP.)
Packages	: SOT-23D QFN-0601
Environmentally Friendly	: EU RoHS Compliant, Pb Free

### TYPICAL APPLICATION CIRCUIT

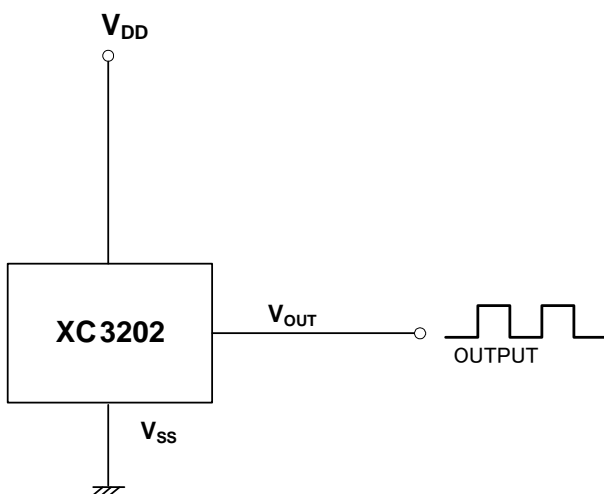

C: Capacitor to stabilize input voltage and decrease noise.

Recommendation value: 10nF~100nF

### TYPICAL PERFORMANCE CHARACTERISTICS

- Supply Current (avg) vs. Ambient Temperature

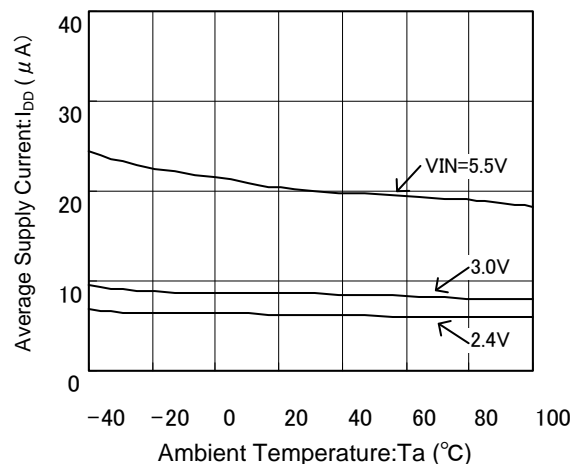

## PIN CONFIGURATION

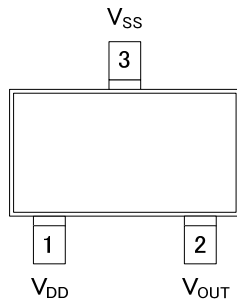

SOT-23D  
(TOP VIEW)

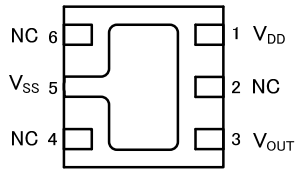

QFN-0601  
(BOTTOM VIEW)

## PIN ASSIGNMENT

PIN NUMBER		PIN NAME	FUNCTION
SOT-23D	QFN-0601		
1	1	$V_{DD}$	Power Input
2	3	$V_{OUT}$	Output Pin
3	5	$V_{SS}$	Ground
-	2,4,6	NC	No Connection

## PRODUCT CLASSIFICATION

### Ordering Information

XC3202①②③④⑤⑥-⑦<sup>(\*)</sup>

DESIGNATOR	ITEM	SYMBOL	DESCRIPTION
①	Product Type	B	CMOS Output
②③④	Product No.	183	Based on the internal standard
⑤⑥-⑦	Packages (Order Unit)	MR-G	SOT-23D (3,000/Reel)
		ZR-G	QFN-0601 (3,000/Reel)

<sup>(\*)</sup> The "-G" suffix indicates that the products are Halogen and Antimony free as well as being fully RoHS compliant.

## ■ BLOCK DIAGRAMS

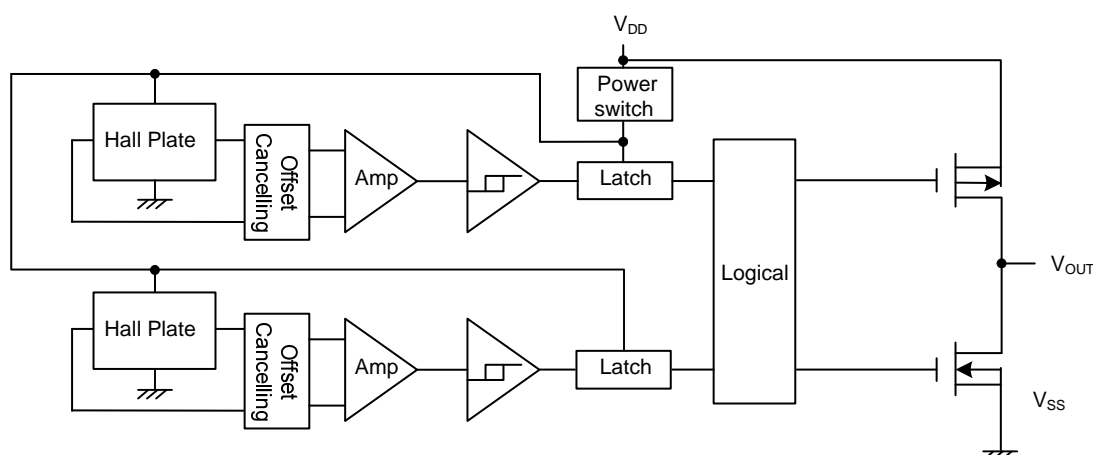

## ■ ABSOLUTE MAXIMUM RATINGS

Ta=25°C

PARAMETER	SYMBOL	RATINGS	UNITS
Supply Voltage	V <sub>DD</sub>	7	V
Magnetic Flux Density	B	Unlimited	-
Operating Temperature Range	T <sub>opr</sub>	-40~+85	°C
Storage Temperature Range	T <sub>stg</sub>	-55~+150	°C
Power Dissipation	SOT-23D	Pd	mW
	QFN-0601		
Maximum Junction Temperature	T <sub>jc</sub>	125	°C
Maximum Output Current	I <sub>OUT</sub>	40	mA

(\*1) This IC should be used within the stated absolute maximum ratings in order to prevent damage.

## ■ ELECTRICAL CHARACTERISTICS

Ta=25°C

PARAMETER	SYMBOL	CONDITONS	MIN.	TYP.	MAX.	UNITS	CIRCUIT
Output ON Voltage (High)	V <sub>OUT_H</sub>	V <sub>DD</sub> =3V, I <sub>OUT</sub> =-1mA	V <sub>DD</sub> -0.2	-	-	V	③
Output ON Voltage (Low)	V <sub>OUT_L</sub>	V <sub>DD</sub> =3V, I <sub>OUT</sub> =1mA	-	-	0.1		
Supply Current	I <sub>DD</sub> (en)	V <sub>DD</sub> =3V	-	3	6	mA	②
	I <sub>DD</sub> (dis)	V <sub>DD</sub> =3V	-	5	10	μA	①
	I <sub>DD</sub> (avg)	V <sub>DD</sub> =3V	-	8	16	μA	②
Detection Time (*1)	t <sub>awake</sub>	V <sub>DD</sub> =3V	-	75	150	μs	②
Detection Period (*1)	t <sub>period</sub>	V <sub>DD</sub> =3V	-	75	150	ms	
Duty Cycle	DTY		-	0.1	-	%	②
Power Supply Voltage	V <sub>DD</sub>		2.4	-	5.5	V	

(\*1) Normal operation starts 150ms later from the supply voltage (V<sub>DD</sub>=2.4~5.5V)

(\*2) For supply current, detection time, and detection period, please refer to the below.

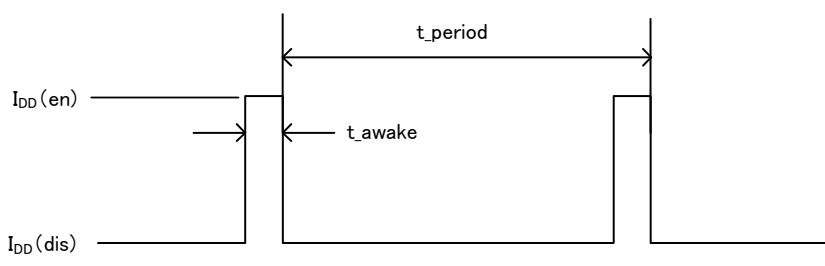

The Hall IC is operated intermittently to reduce supply current.

Measurement is done during detection time, in the rest period sensing circuits of Hall plate and latch are turned off to minimize the current.

## MAGNETIC STATE CHARACTERISTICS

Ta=25°C, V<sub>DD</sub>=3V, 1mT=10Gauss

PARAMETER	SYMBOL	MIN.	TYP.	MAX.	UNITS	CIRCUIT
Operating Magnetic Flux Density: South Pole	Bops	2	3	4	mT	③
Operating Magnetic Flux Density: North Pole	Bopn	-4	-3	-2	mT	③
Release Magnetic Flux Density: South Pole	Brps	1	2	-	mT	③
Release Magnetic Flux Density: North Pole	Brpn	-	-2	-1	mT	③
Hysteresis Width	Bhy(Bop-Brp)	0.5	1	-	mT	③

\* Characteristics Values are guaranteed in design. The values may be affected by the conditions such as temperature and mounting.

### Magnetic field and detect surface

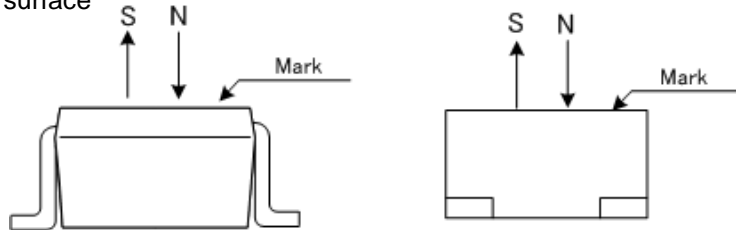

The IC Hall plates detect the perpendicular magnetic field so that IC surface should be placed in a direction perpendicular to the magnetic field.

## OPERATIONAL

### Operating by flux density

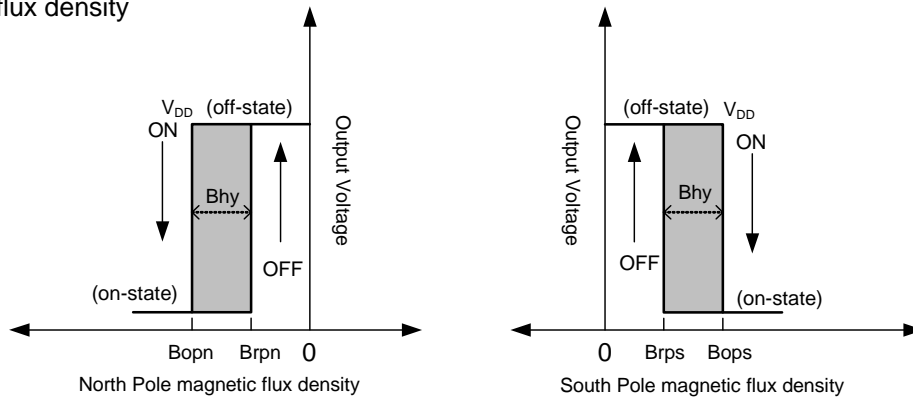

### Timing chart

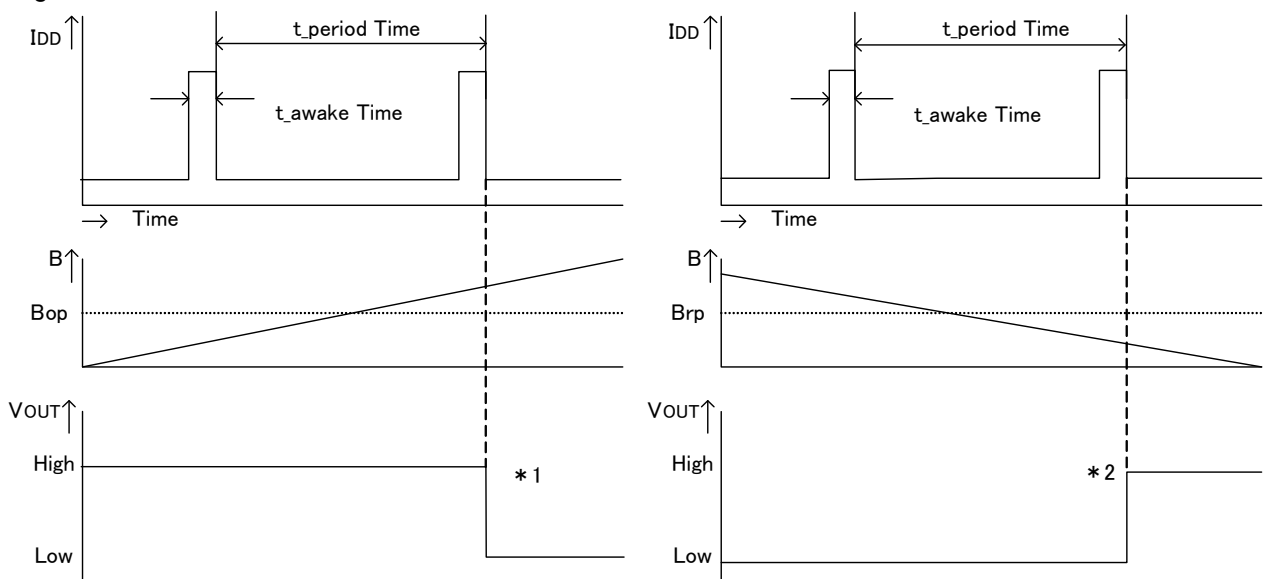

\*1: When the magnetic flux density to the IC becomes larger than Bop, the IC goes into an on-state and outputs a low signal (V<sub>OUT</sub>=Low) at the leading edge of the next "awake" pulse.

\*2: When the magnetic flux density to the IC becomes lower than Brp, the IC goes into an off-state and outputs a high signal (V<sub>OUT</sub>=High) at the leading edge of the next "awake" pulse.

During the other periods, the previous state is maintained.

## ■ NOTES ON USE

1. The magnetic flux density will be changed when an external capacitor ( $C_{IN}$ ) is connected between  $V_{DD}$  and  $V_{SS}$ .

North Pole Magnetic Flux Density vs. Input Capacitance ( $C_{IN}$ )

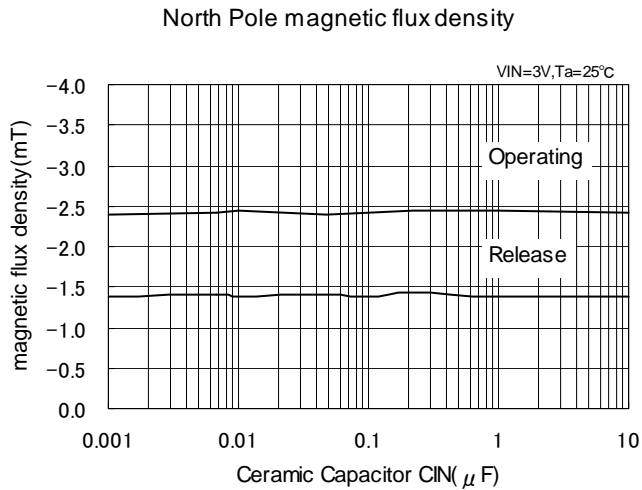

South Pole Magnetic Flux Density vs. Input Capacitance ( $C_{IN}$ )

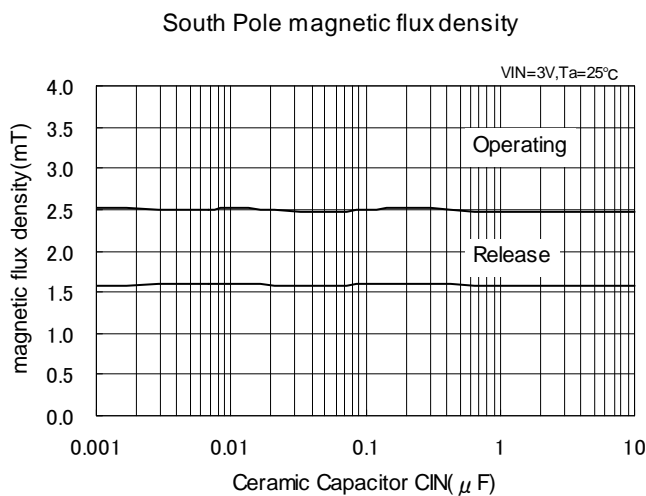

2. Please use this IC within the stated maximum ratings. For temporary, transitional voltage drop or voltage rising phenomenon, the IC is liable to malfunction should the ratings be exceeded.
3. Torex places an importance on improving our products and its reliability. However, by any possibility, we would request user fail-safe design and post-aging treatment on system or equipment.

## TEST CIRCUITS

Circuit ①

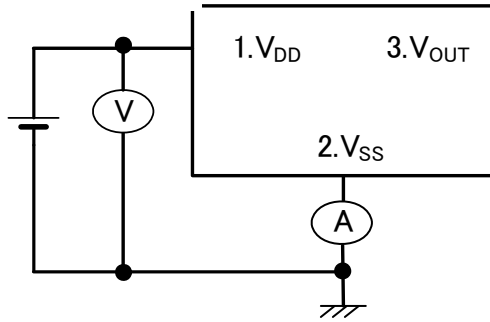

Circuit ②

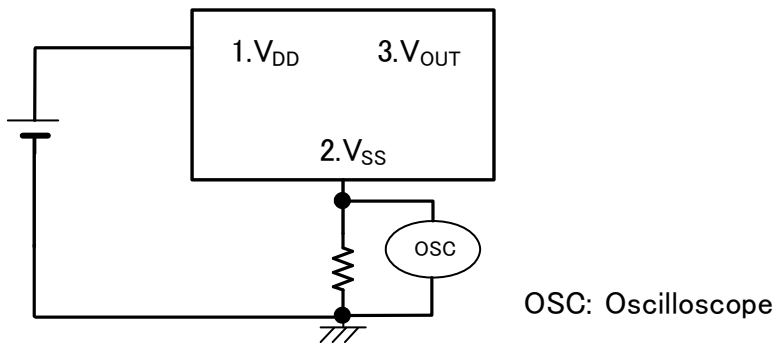

Circuit ③

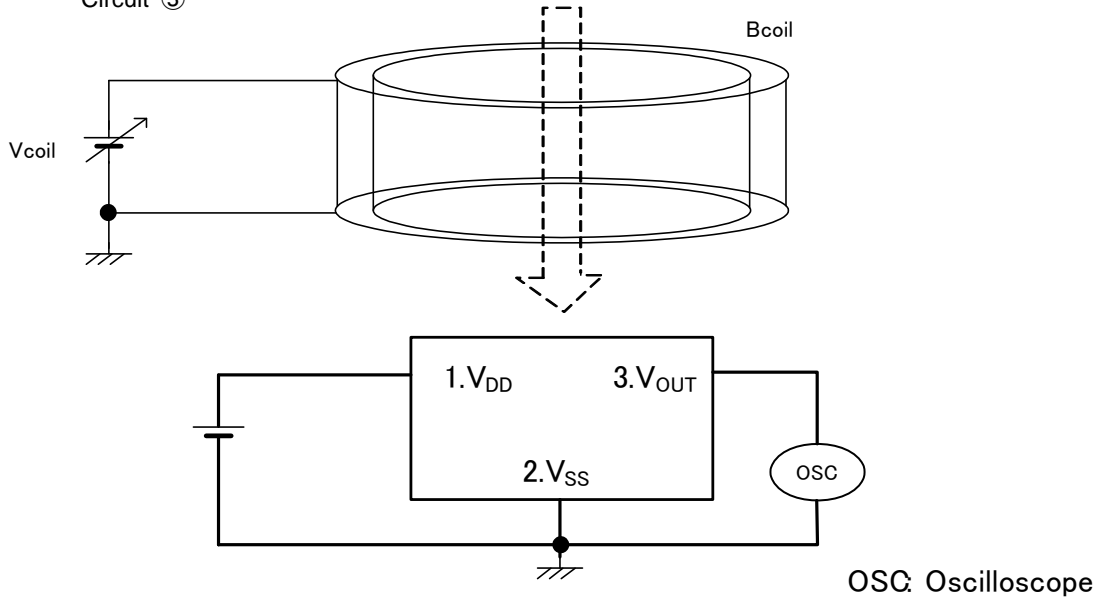

## PACKAGING INFORMATION

### ● SOT-23D

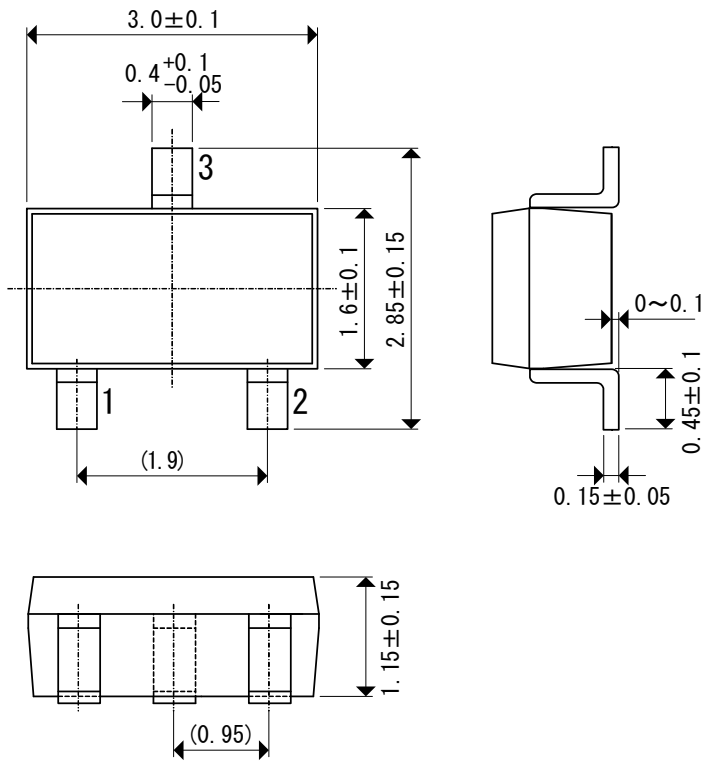

### ● Sensor Position

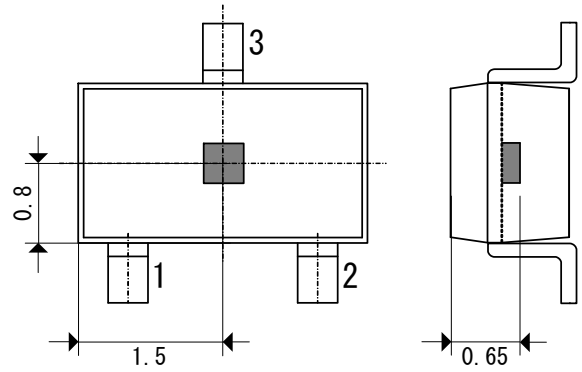

### ● QFN-0601

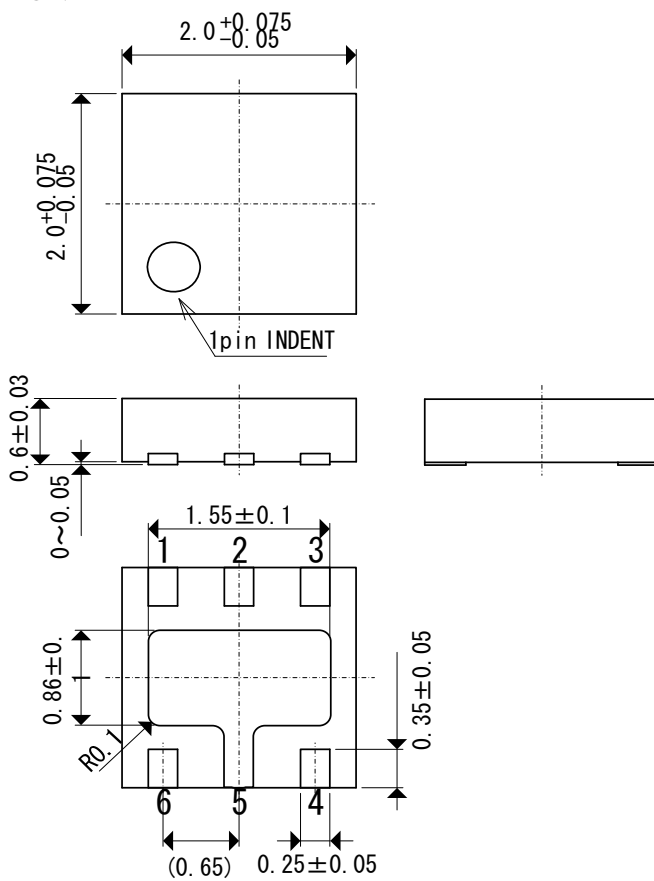

### ● Sensor Position

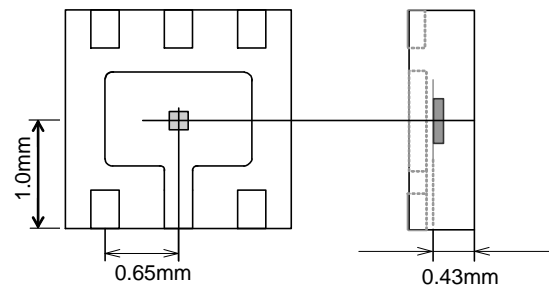

## MARKING RULE

### ● SOT-23D / QFN-0601

① represents product series

MARK	PRODUCTS SERIES
2	XC3202*****-G

② represents product registration.

MARK	PRODUCTS SERIES
3	XC3202B183

③ represents a least significant digit of production year

(ex.)

MARK	PRODUCTION YEAR
0	2010
1	2011

④ represents production month.

MARK	PRODUCTION MONTH	MARK	PRODUCTION MONTH	MARK	PRODUCTION MONTH
A	January	E	May	J	September
B	February	F	June	K	October
C	March	G	July	L	November
D	April	H	August	M	December

⑤ represents production lot number. A~Z repeated.  
(G, I, J, O, Q, W excluded)

### ● SOT-23D

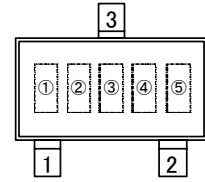

### ● QFN-0601

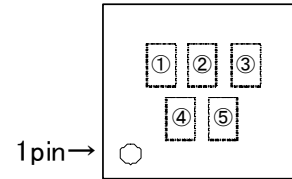



1. The products and product specifications contained herein are subject to change without notice to improve performance characteristics. Consult us, or our representatives before use, to confirm that the information in this datasheet is up to date.
2. We assume no responsibility for any infringement of patents, patent rights, or other rights arising from the use of any information and circuitry in this datasheet.
3. Please ensure suitable shipping controls (including fail-safe designs and aging protection) are in force for equipment employing products listed in this datasheet.
4. The products in this datasheet are not developed, designed, or approved for use with such equipment whose failure or malfunction can be reasonably expected to directly endanger the life of, or cause significant injury to, the user.  
(e.g. Atomic energy; aerospace; transport; combustion and associated safety equipment thereof.)
5. Please use the products listed in this datasheet within the specified ranges.  
Should you wish to use the products under conditions exceeding the specifications, please consult us or our representatives.
6. We assume no responsibility for damage or loss due to abnormal use.
7. All rights reserved. No part of this datasheet may be copied or reproduced without the prior permission of TOREX SEMICONDUCTOR LTD.

**TOREX SEMICONDUCTOR LTD.**