

-16V Input Three Terminal Negative Voltage Regulator

■ GENERAL DESCRIPTION

The XC6902 Series is a negative voltage CMOS regulator which includes a reference voltage source, error amplifiers, driver transistors, current limiters and phase compensators.

XC6902 is a 3 terminal negative voltage regulator (without CE pin) which is capable of accepting -16V input.

The over current protection circuit will operate when the output current reaches limit current. The thermal shutdown circuit will operate when the junction temperature reaches limit temperature.

■ APPLICATIONS

- CCD power supplies
- LCD Modules
- Op-Amp power supplies
- Digital still cameras
- Battery powered equipment

■ FEATURES

Maximum Output Current	: 200mA
Input Voltage Range	: -2.4 ~ -16V
Output Voltage Range	: -2.5V,-2.6V,-3.0V,-3.3V,-4.0V,-4.5V,-5.0V,-6.0V,-12.0V
Accuracy	: ±1.5% for -2.0V~-12V
Temperature Stability	: TYP. ±50ppm/°C
Dropout Voltage	: 400mV@ $I_{OUT}=100mA$
Low Power Consumption	: 100 μA
Protection Circuits	: Current Limit 350mA TYP. Foldback Thermal Shutdown (150°C)
Output Capacitor	: Ceramic Capacitor Compatible
Operating Ambient Temperature	: -40°C~+85°C
Packages	: SOT-23, SOT-89, USP-6C
Environmentally Friendly	: EU RoHS Compliant, Pb Free

■ TYPICAL APPLICATION CIRCUIT

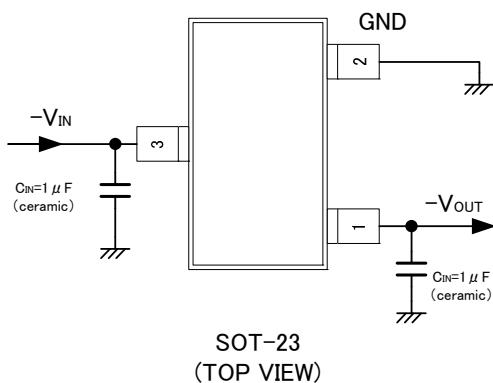

■ TYPICAL PERFORMANCE CHARACTERISTICS

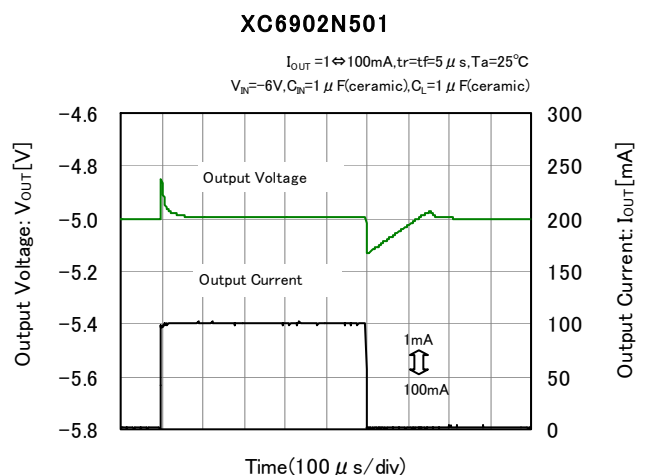

PIN CONFIGURATION

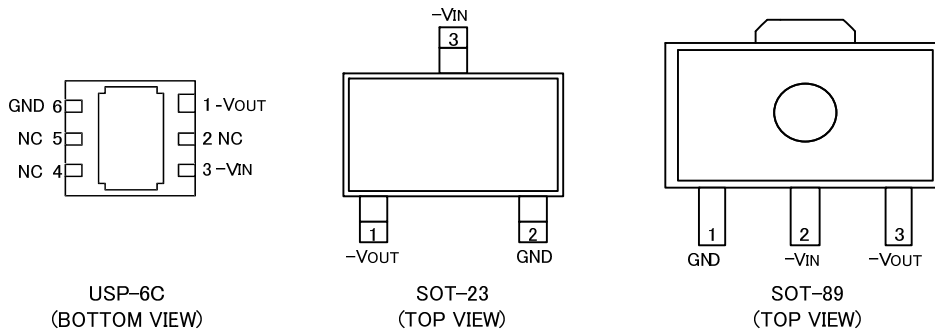

* The dissipation pad for the USP-6C package should be solder-plated in recommended mount pattern and metal masking to enhance mounting strength and heat release. If the pad needs to be connected to other pins, it should be connected to the -V_{IN} (No. 3) pin.

PIN ASSIGNMENT

PIN NUMBER			PIN NAME	FUNCTIONS
USP-6C	SOT-23	SOT-89		
3	3	2	-V _{IN}	Negative Supply Input
1	1	3	-V _{OUT}	Negative Output
6	2	1	GND	Ground
2,4,5	-	-	NC	No Connection

■ PRODUCT CLASSIFICATION

● Ordering Information

XC6902①②③④⑤⑥-⑦^(*) Three Terminal Voltage Regulator

DESIGNATOR	ITEM	SYMBOL	DESCRIPTION
①	Type	N	Soft-start, Thermal Shutdown
②③④	Output Voltage ^(*) (Accuracy)	251	-2.5V (±1.5%)
		261	-2.6V (±1.5%)
		301	-3.0V (±1.5%)
		331	-3.3V (±1.5%)
		401	-4.0V (±1.5%)
		451	-4.5V (±1.5%)
		501	-5.0V (±1.5%)
		601	-6.0V (±1.5%)
		C01	-12.0V (±1.5%)
⑤⑥-⑦	Packages (Order Unit)	ER-G	USP-6C(3,000/Reel)
		MR-G	SOT-23 (3,000/Reel)
		PR-G	SOT-89(1,000/Reel)

^(*) The "-G" suffix indicates that the products are Halogen and Antimony free as well as being fully RoHS compliant.

^(*) For other output voltages, please contact your local Torex sales office or representative. The output voltage optional range is -0.9V to -12V.

■ ABSOLUTE MAXIMUM RATINGS

GND=0V, Ta=25°C

PARAMETER	SYMBOL	RATINGS	UNITS
Input Voltage	V_{IN}	GND-18 ~ GND+0.3	V
Output Current ^(*1)	I_{OUT}	500	mA
Output Voltage	V_{OUT}	$V_{IN}-0.3 \sim V_{IN}+18$	V
Power Dissipation	Pd	120	mW
		1000 (PCB mounted)	
		250	
		500 (PCB mounted)	
		1000 (PCB mounted)	
Operating Ambient Temperature	Topr	-40~+85	°C
Storage Temperature	Tstg	-55~+125	°C

(*1) Please use within the range of $I_{OUT} \leq Pd / (V_{OUT} - V_{IN})$

■ BLOCK DIAGRAM

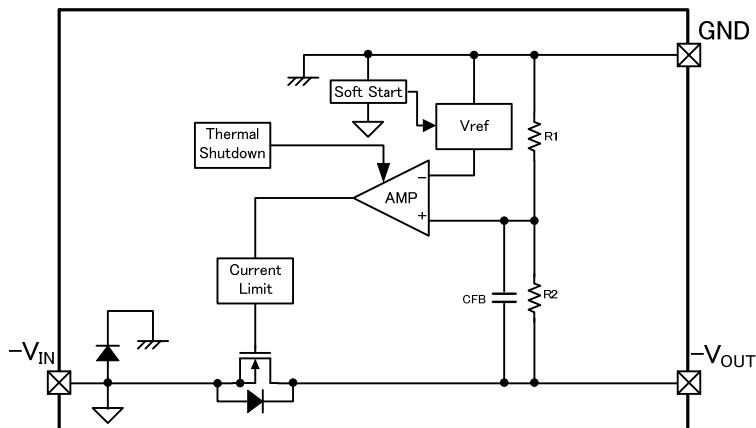

*Diodes inside the circuit are an ESD protection diode and a parasitic diode.

ELECTRICAL CHARACTERISTICS

●XC6902 Series

T_a=25°C

PARAMETER	SYMBOL	CONDITIONS		MIN.	TYP.	MAX.	UNITS	CIRCUIT
Output Voltage	V _{OUT(E)} ^(*)2)	I _{OUT} =20mA	V _{OUT(T)} <-2.0V	×1.015	V _{OUT(T)} ^(*)1)	×0.985	V	①
			V _{OUT(T)} ≥-2.0V	-0.030		+0.030		
Maximum Output Current ^(*)4)	I _{OUTMAX}	V _{IN} =V _{OUT(T)} -2.0V	V _{OUT(T)} ≤-2.4V	200	-	-	mA	①
		V _{IN} =-4.4V	V _{OUT(T)} >-2.4V					
Load Regulation	ΔV _{OUT}	V _{IN} =V _{OUT(T)} -1.0V	V _{OUT(T)} ≤-3.0V	-	20	60	mV	①
		V _{IN} =-4.0V	V _{OUT(T)} >-3.0V					
		1mA≤I _{OUT} ≤100mA						
Dropout Voltage	V _{dif} ^(*)3)	I _{OUT} =20mA		-	E-1 ^(*)5)		mV	①
Supply Current	I _{BIAS}	V _{IN} =-16V, I _{OUT} =0mA		-	100	200	μA	①
Input Line Regulation	ΔV _{OUT} / (ΔV _{IN} · V _{OUT})	V _{IN} : -16V~-2.4V	V _{OUT(T)} >-1.4V	-	0.05	0.20	%V	①
		V _{IN} : -16V~ V _{OUT(T)} -1V	-9≤V _{OUT(T)} ≤-1.4V					
		V _{IN} : -16V~ V _{OUT(T)} -1V	V _{OUT(T)} <-9.0V	-	0.1	0.30		
		I _{OUT} =20mA						
Input Voltage	V _{IN}			-16	-	-2.4	V	①
Output Voltage Temperature Characteristics	ΔV _{OUT} / (ΔT _{opr} · V _{OUT})	I _{OUT} =20mA -40°C≤T _{opr} ≤85°C		-	±50	-	ppm/°C	①
Ripple Rejection Ratio	PSRR	V _{IN} ={V _{OUT(T)} -1.0}+0.5Vp-pAC, I _{OUT} =20mA, f=1kHz		-	45	-	dB	②
Limit Current	I _{LIM}	V _{IN} =V _{OUT(T)} -2.0V	V _{OUT(T)} ≤-2.4V	210	300	-	mA	①
		V _{IN} =-4.4V	V _{OUT(T)} >-2.4V					
Short-Circuit Current	I _{SHORT}	V _{IN} =V _{OUT(T)} -2.0V Short -V _{OUT} to GND level		-	80	-	mA	①
Detect Thermal Shutdown Temperature	T _{TSD}	IC Junction temperature		-	150	-	°C	①
Release Thermal Shutdown Temperature	T _{TSR}	IC Junction temperature		-	125	-	°C	①
Hysteresis Width	T _{HYS}	T _{TSD} -T _{TSR}		-	25	-	°C	①
Soft Start Time	t _{SS}	R _L =3kΩ ^(*)6)	V _{OUT(T)} >-4.0V	0.12	0.4	1.2	ms	③
			V _{OUT(T)} ≤-4.0V	0.2	0.7	2	ms	③

NOTE:

The test condition for input voltage, Unless otherwise stated, GND=0V, V_{IN}=V_{OUT(T)}-1.0V or -2.4V.

*1) V_{OUT(T)}: Nominal output voltage

*2) V_{OUT(E)}: Effective output voltage (see the voltage chart)

(ie. The output voltage when “V_{OUT(T)}-1.0V” or “-2.4V” is provided at the V_{IN} pin while maintaining a certain I_{OUT} value.

*3) V_{dif}={-V_{IN1}- V_{OUT1}}

V_{IN1} is the input voltage when V_{OUT1} appears at the V_{OUT} pin while input voltage is gradually increased

V_{OUT1} is the voltage equal to 98% of the normal output voltage when amply stabilized V_{OUT(T)} -1.0V or -2.4V (the bigger absolute value one) are input at the V_{IN} pin.

*4) The maximum current may not be able to flow when thermal shutdown operates, it depends on power dissipation.

*5) E-1: Refer to Dropout Voltage Chart.

*6) Input voltage condition is V_{IN}=0V → V_{OUT}-1V with 5μs rising time.

Soft-start time t_{SS} is defined as the time taken from the 90% rising of V_{IN} to the 95% rising of V_{OUT(E)}.

■ ELECTRICAL CHARACTERISTICS(Continued)

Dropout Voltage Chart

NOMINAL OUTPUT VOLTAGE	E-1	
	DROPOUT VOLTAGE	
	Vdif (mV)	
V _{OUT(T)}	TYP.	MAX.
-2.50	129	174
-2.60	125	169
-3.00	110	151
-3.30	102	142
-4.00	91	127
-5.00	78	114
-6.0	70	105
-12.0	50	87

TEST CIRCUIT

1) CIRCUIT①

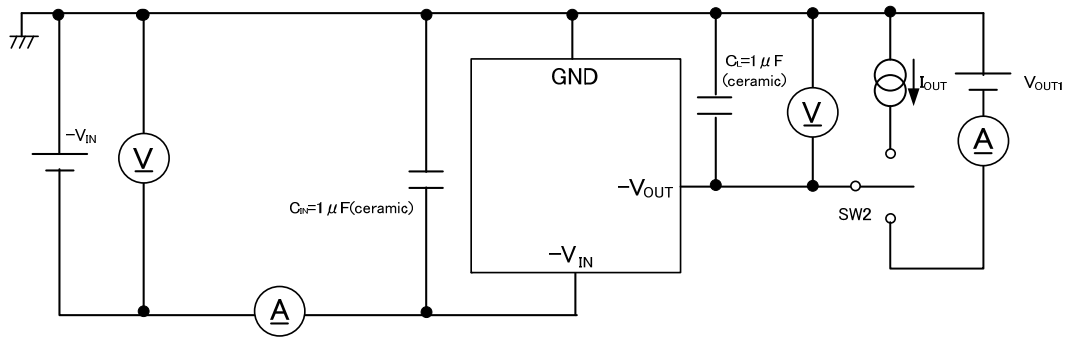

2) CIRCUIT②

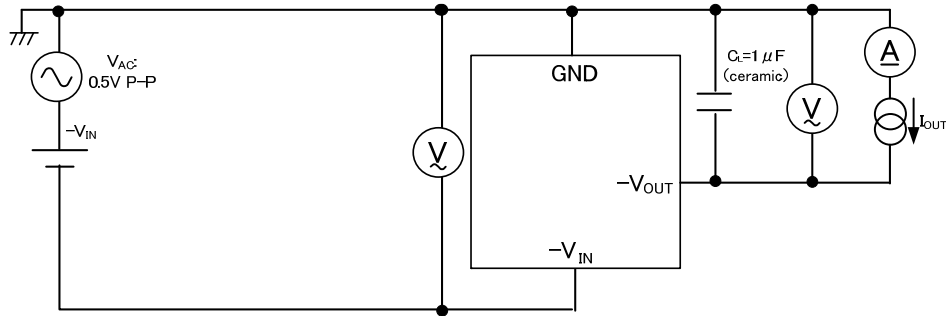

3) CIRCUIT③

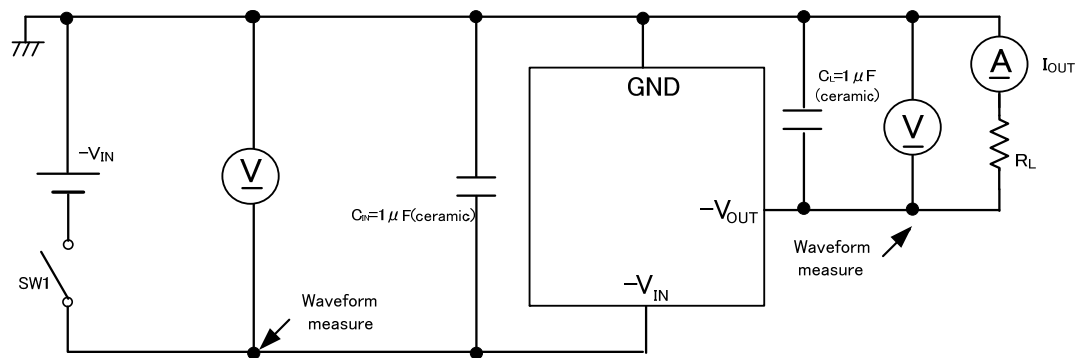

OPERATIONAL EXPLANATION

The voltage divided by resistors R1 and R2 is compared with the internal reference voltage based on ground by the error amplifier.

The driver transistor tied to the $-V_{IN}$ pin is then driven by the subsequent output signal. The output voltage at the $-V_{OUT}$ pin is controlled and stabilized by a system of negative feedback.

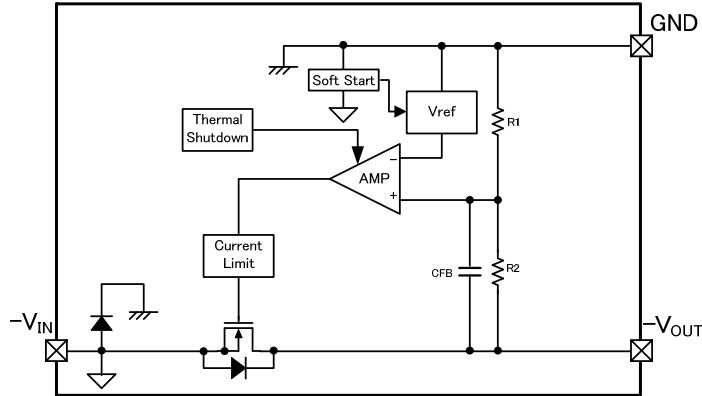

XC6902 Series

< Soft-Start Function >

The XC6902 series includes soft-start circuit. During power start-up, the inrush current from $-V_{IN}$ pin to V_{OUT} pin to charge C_L capacitor can be reduced and it makes the V_{IN} stable. Soft-start time (t_{SS}) is optimized internally.

Figure1: Soft-Start Time and Inrush Current

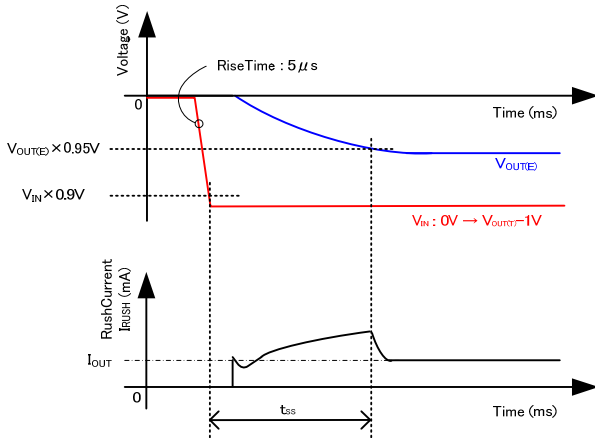

< Current Limiter, Short-Circuit Protection >

The XC6902 series fold-back circuit operates as an output current limiter and a short protection circuit for the output pin. When the output current reaches the current limit level, output voltage drops with the decrease of the output current.

There are no parasitic diode between the $-V_{OUT}$ pin and GND pin. The minimized short-circuit current is maintained even if the $-V_{OUT}$ pin voltage is pulled up toward positive.

< Thermal Shutdown >

The XC6902 Series has an internal thermal shutdown (TSD) circuit for protection against overheating.

When the junction temperature reaches the detection temperature, the driver transistor is forcibly turned off. When the junction temperature falls to the release temperature with the driver transistor still in the off state, the driver transistor turns on (automatic recovery) and restarts regulator operation.

■ OPERATIONAL EXPLANATION (Continued)

<Low ESR Capacitor>

With the XC6902 series, a stable output voltage is achievable even if used with low ESR capacitors, as a phase compensation circuit is built-in. The output capacitor (C_L) should be connected as close to V_{OUT} pin and GND pin to obtain stable phase compensation. Values required for the phase compensation are as the table below.

For a stable power input, please connect an input capacitor (C_{IN}) near power supply. In order to ensure the stable phase compensation while avoiding run-out of values, please use the capacitor (C_{IN} , C_L) which does not depend on bias or temperature too much. The table below shows recommended values of C_{IN} , C_L .

CHART 1 : Recommended Values of C_{IN} , C_L

OUTPUT VOLTAGE RANGE	INPUT CAPACITOR	OUTPUT CAPACITOR
$V_{OUT(T)}$	C_{IN}	C_L
-0.9V~-12V	1.0 μ F~	1.0 μ F~100 μ F

■ NOTES ON USE

1. Please use this IC within the stated maximum ratings. For temporary, transitional voltage drop or voltage rising phenomenon, the IC is liable to malfunction should the ratings be exceeded.
2. Where wiring impedance is high, operations may become unstable due to noise and/or phase lag depending on output current. Please keep the resistance low for the $-V_{IN}$ and GND wiring in particular.
3. Please wire the C_{IN} and C_L as close to the IC as possible.
4. Capacitances of these capacitors (C_{IN} , C_L) are decreased by the influences of bias voltage and ambient temperature. Care shall be taken for capacitor selection to ensure stability of phase compensation from the point of ESR influence.
5. Torex places an importance on improving our products and its reliability.
However, by any possibility, we would request user fail-safe design and post-aging treatment on system or equipment.

TYPICAL PERFORMANCE CHARACTERISTICS

(1) Output Voltage vs. Output Current

XC6902N331

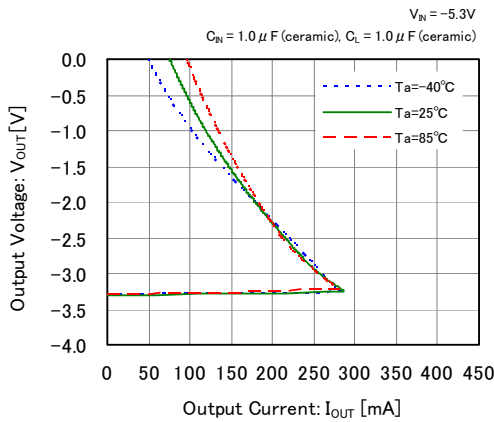

XC6902N331

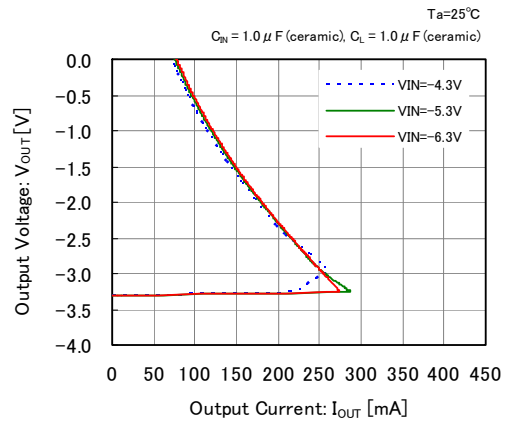

XC6902N501

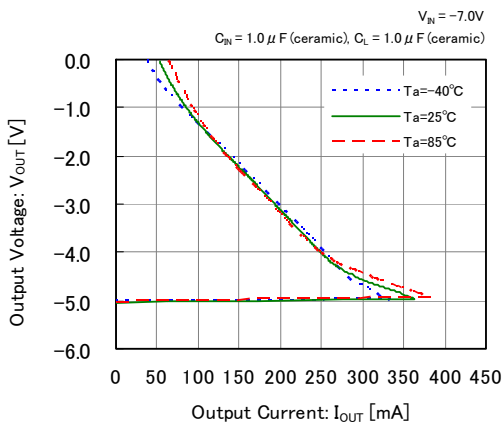

XC6902N501

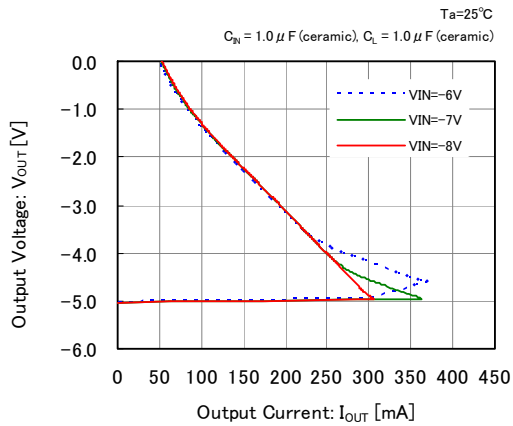

XC6902NC01

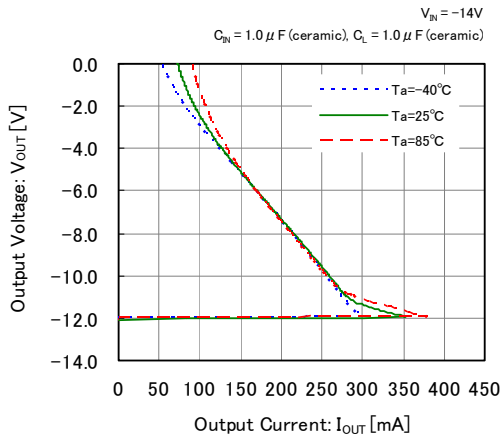

XC6902NC01

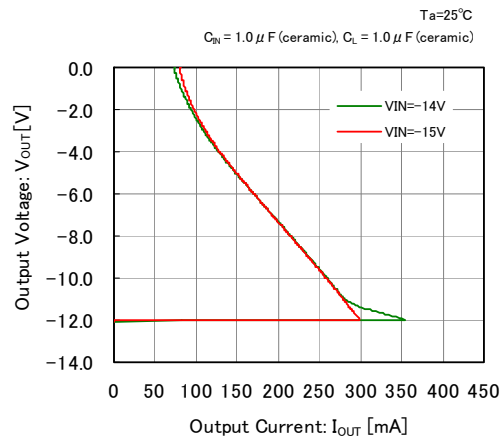

■ TYPICAL PERFORMANCE CHARACTERISTICS (Continued)

(2) Output Voltage vs. Input Voltage

XC6902N331

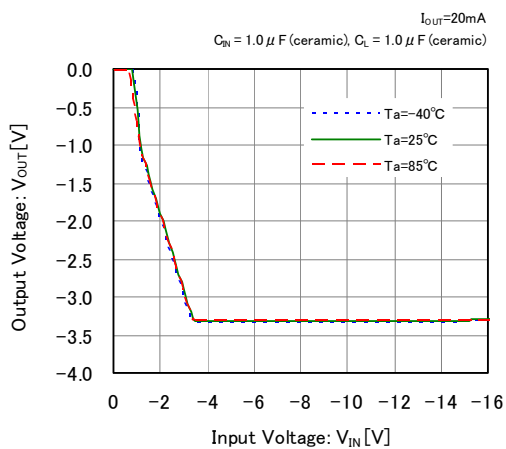

XC6902N331

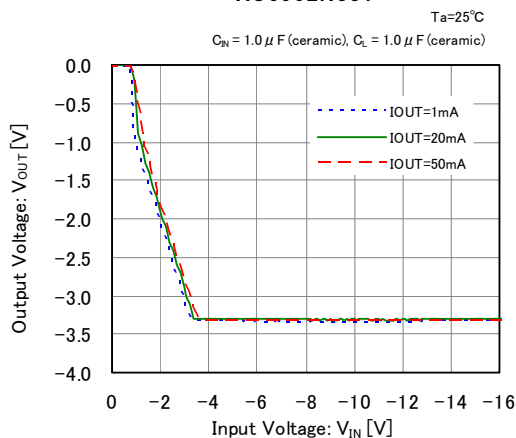

XC6902N501

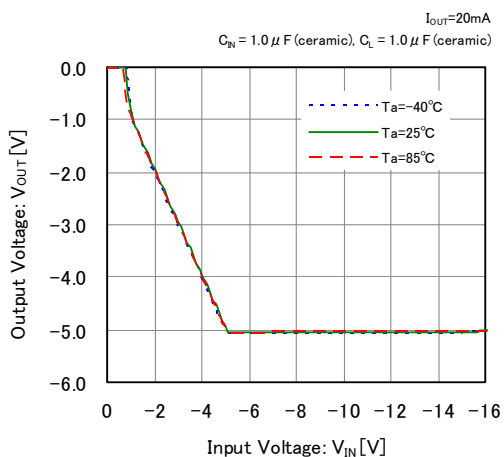

XC6902N501

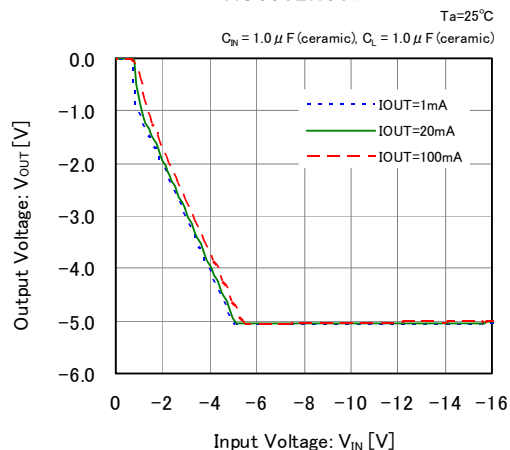

XC6902NC01

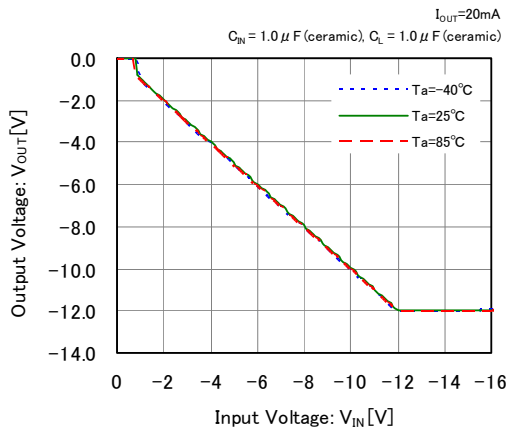

XC6902NC01

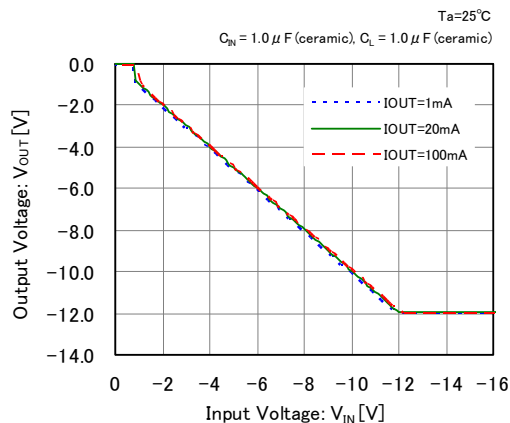

TYPICAL PERFORMANCE CHARACTERISTICS (Continued)

(3) Dropout Voltage vs. Output Current

XC6902N331

$C_N = 1.0 \mu\text{F}$ (ceramic), $C_L = 1.0 \mu\text{F}$ (ceramic)

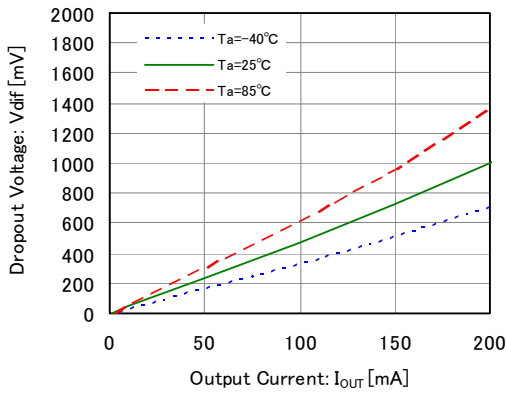

XC6902N501

$C_N = 1.0 \mu\text{F}$ (ceramic), $C_L = 1.0 \mu\text{F}$ (ceramic)

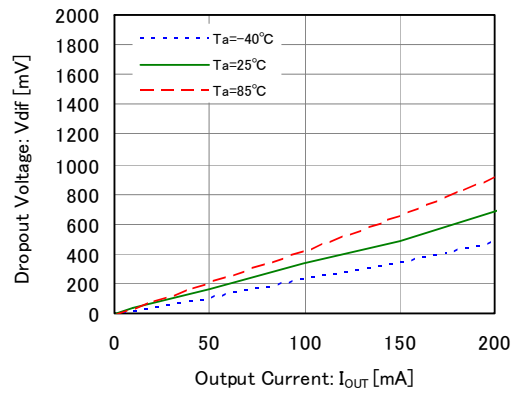

XC6902NC01

$C_N = 1.0 \mu\text{F}$ (ceramic), $C_L = 1.0 \mu\text{F}$ (ceramic)

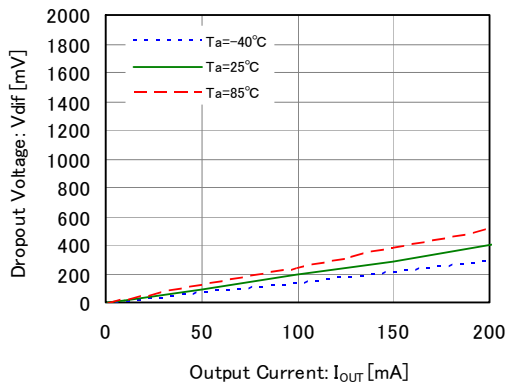

XC6902N331

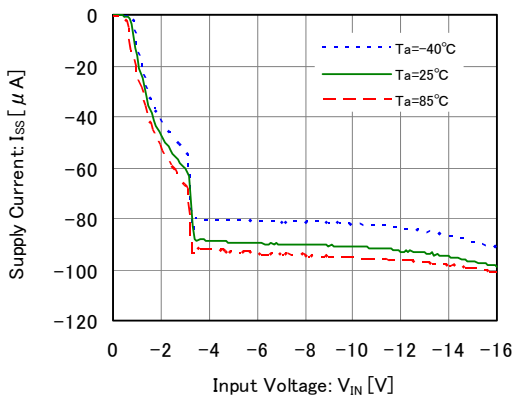

XC6902N501

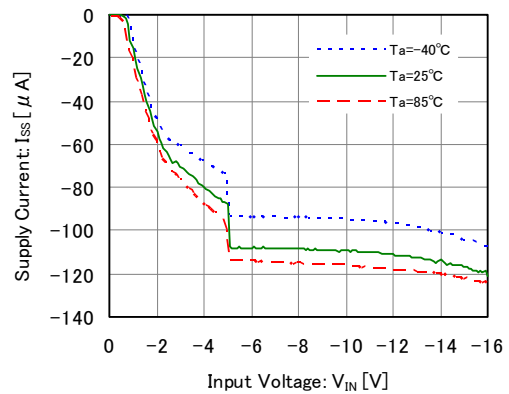

■ TYPICAL PERFORMANCE CHARACTERISTICS (Continued)

(4) Supply Current vs. Input Voltage

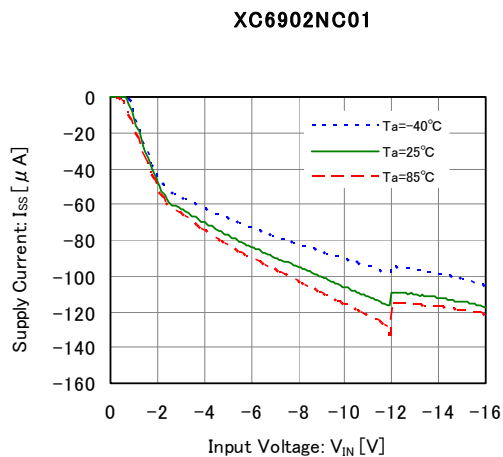

(5) Output Voltage vs. Ambient Temperature

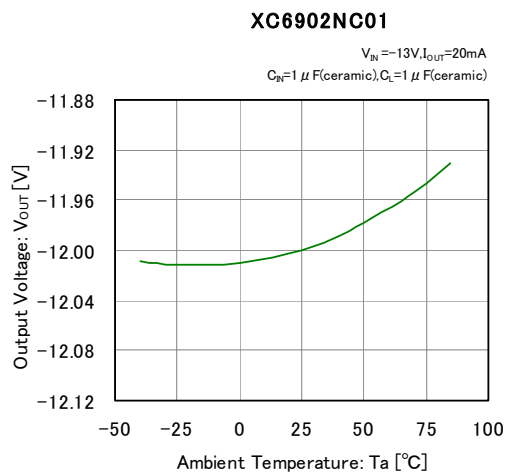
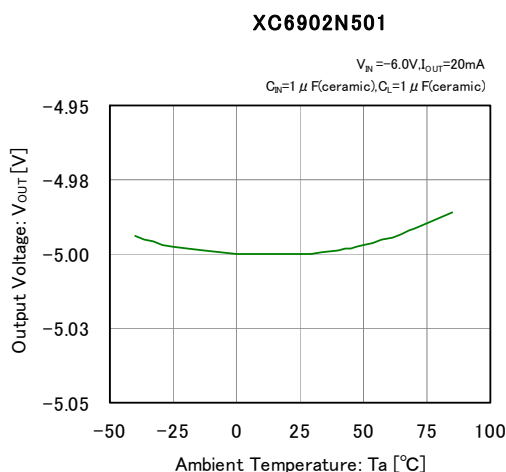
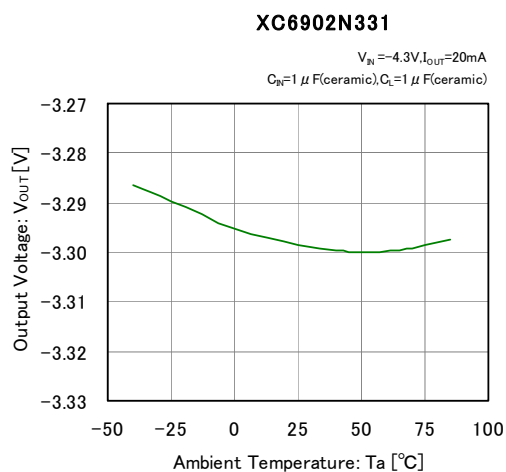

TYPICAL PERFORMANCE CHARACTERISTICS (Continued)

(6) Input Rising Response Time

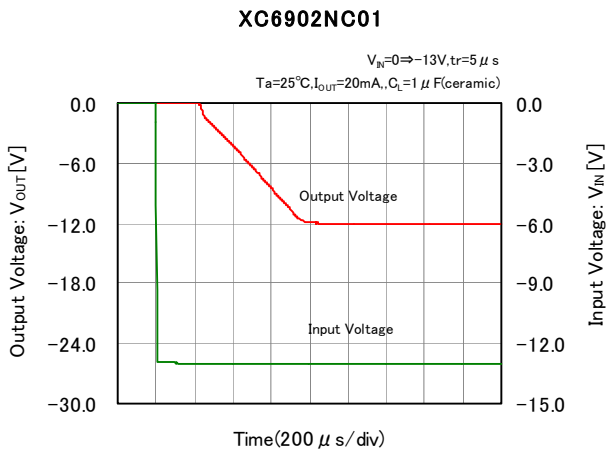
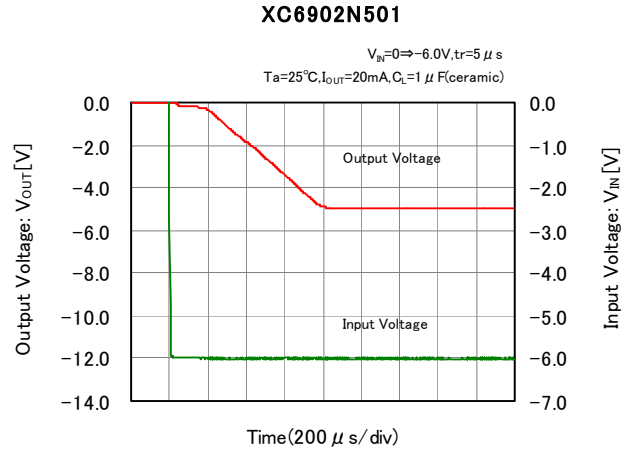
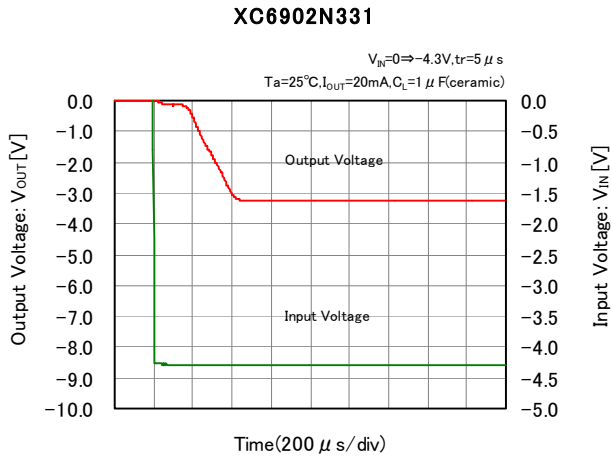

(7) Input Transient Response

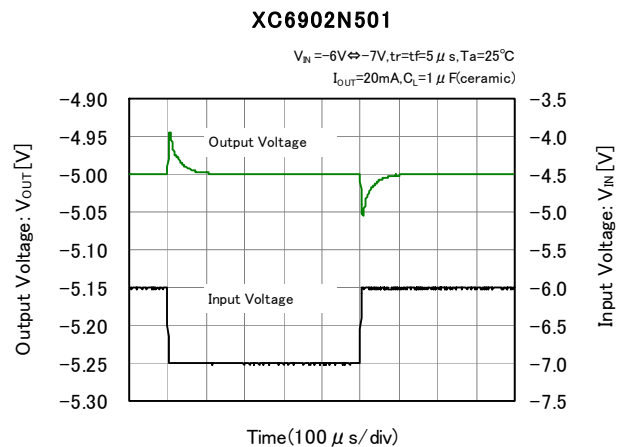
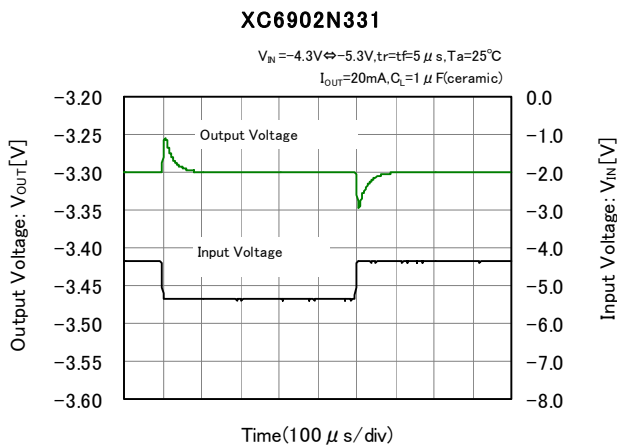

■ TYPICAL PERFORMANCE CHARACTERISTICS (Continued)

(7) Input Transient Response (Continued)

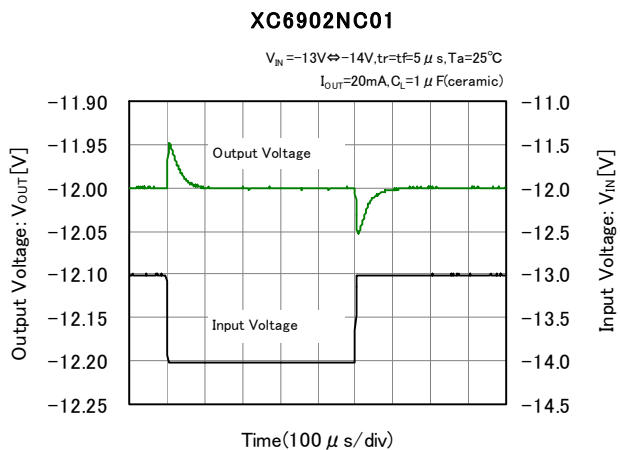

(8) Load Transient Response

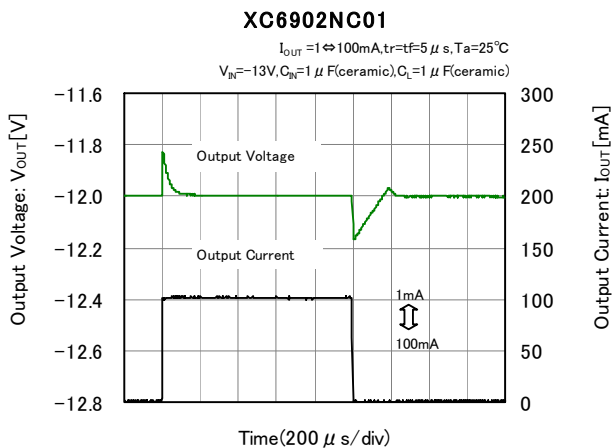
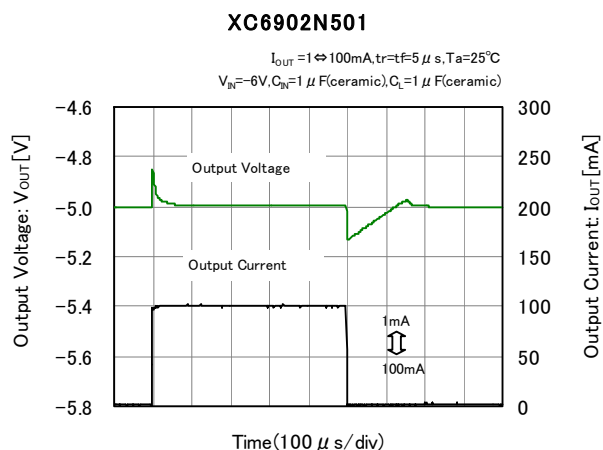
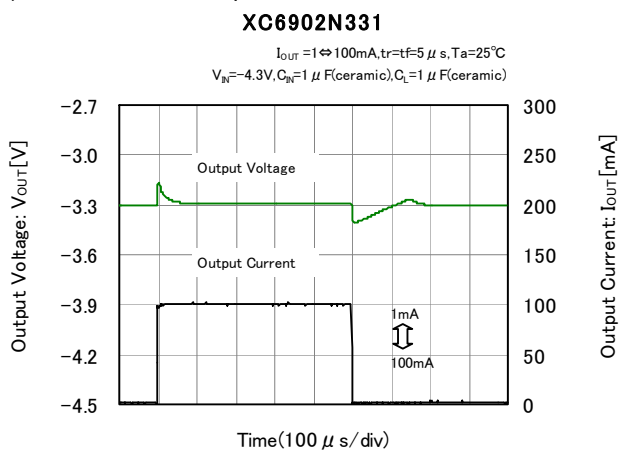

TYPICAL PERFORMANCE CHARACTERISTICS (Continued)

(9) Ripple Rejection Rate

XC6902N331

$T_a=25^\circ\text{C}$, $V_{IN}=-4.3\text{V}+0.5V_{P-PAC}$
 $C_L=1\ \mu\text{F(ceramic)}$

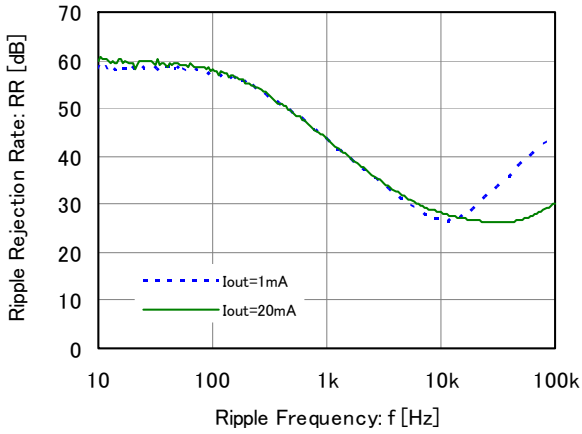

XC6902N501

$T_a=25^\circ\text{C}$, $V_{IN}=-6\text{V}+0.5V_{P-PAC}$
 $C_L=1\ \mu\text{F(ceramic)}$

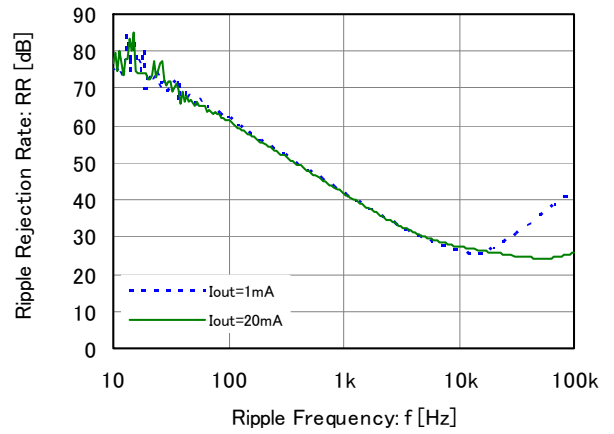

XC6902NC01

$T_a=25^\circ\text{C}$, $V_{IN}=-13\text{V}+0.5V_{P-PAC}$
 $C_L=1\ \mu\text{F(ceramic)}$

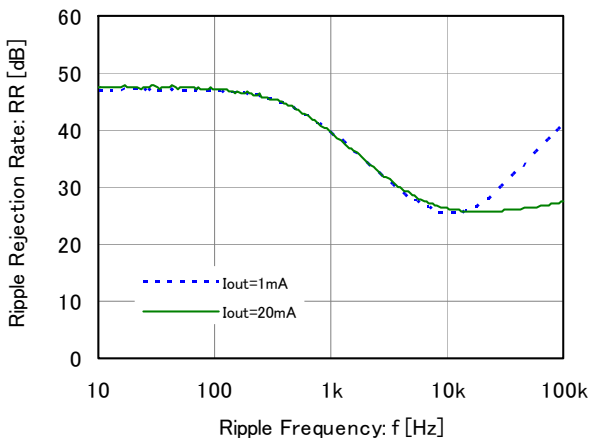

PACKAGING INFORMATION

●SOT-23

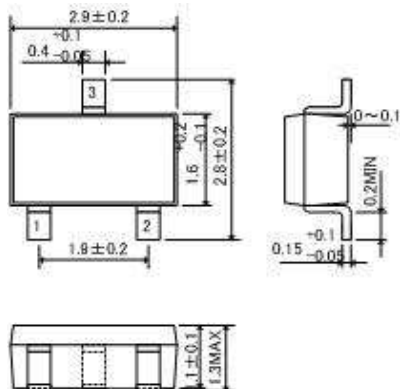

●SOT-89

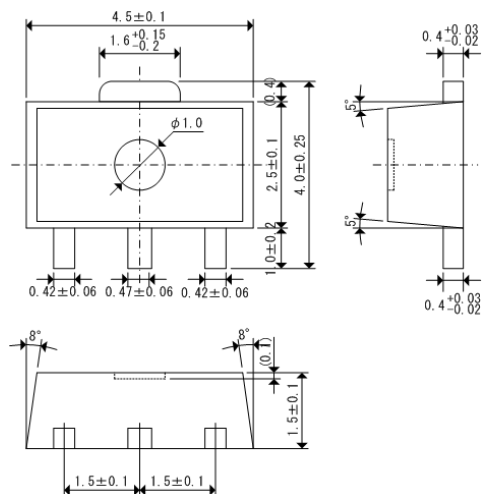

●USP-6C

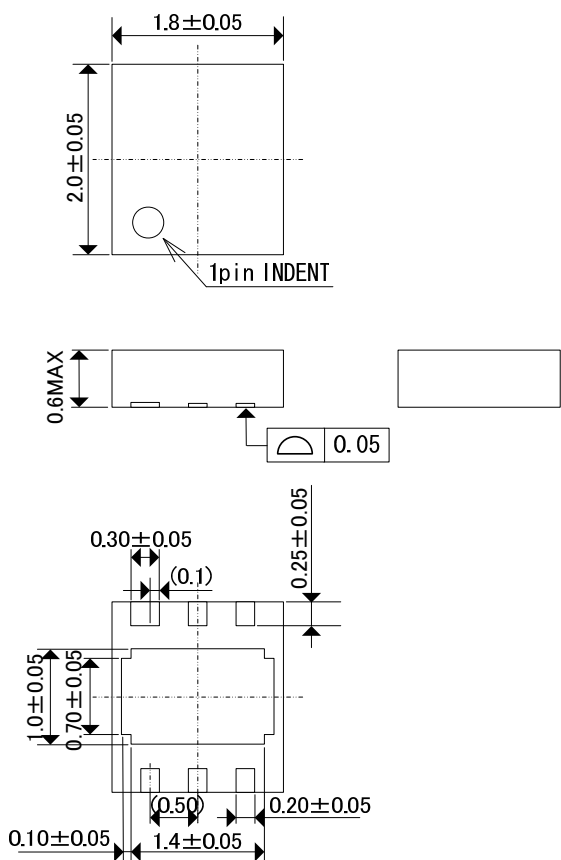

Reference Pattern Layout Dimension

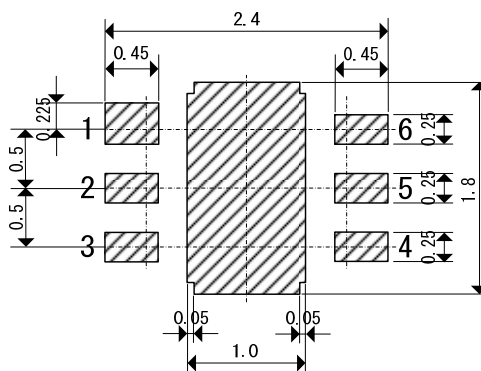

Reference Metal Mask Design

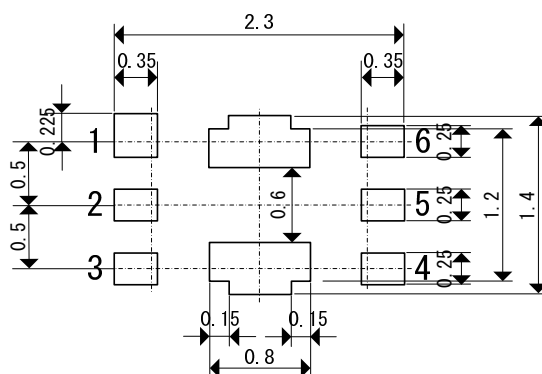

●SOT-23 Power Dissipation

Power dissipation data for the SOT-23 is shown in this page.
 The value of power dissipation varies with the mount board conditions.
 Please use this data as one of reference data taken in the described condition.

1. Measurement Condition (Reference data)

Condition : Mount on a board
 Ambient : Natural convection
 Soldering : Lead (Pb) free

Board : Dimensions 40×40mm (1600mm² in one side)
 Copper (Cu) traces occupy 50% of the board area
 In top and back faces
 Package heat-sink is tied to the copper traces
 (Board of SOT-26 is used)

Material : Glass Epoxy (FR-4)
 Thickness : 1.6mm
 Through-hole : 4 x 0.8 Diameter

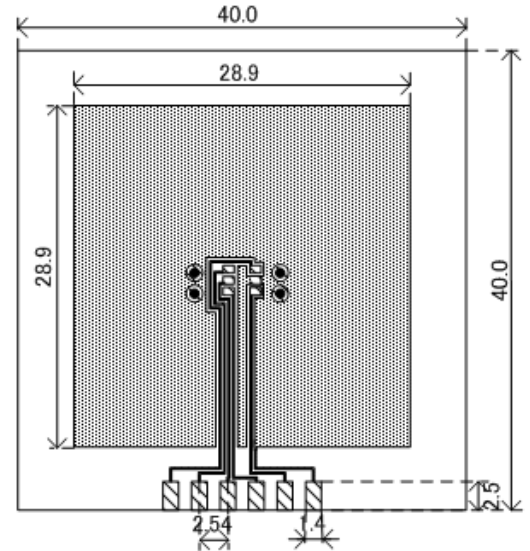

Evaluation Board (Unit: mm)

2. Power Dissipation vs. Ambient temperature

Board Mount (Tjmax=125°C)

Ambient Temperature (°C)	Power Dissipation Pd (mW)	Thermal Resistance (°C/W)
25	500	200.00
85	200	

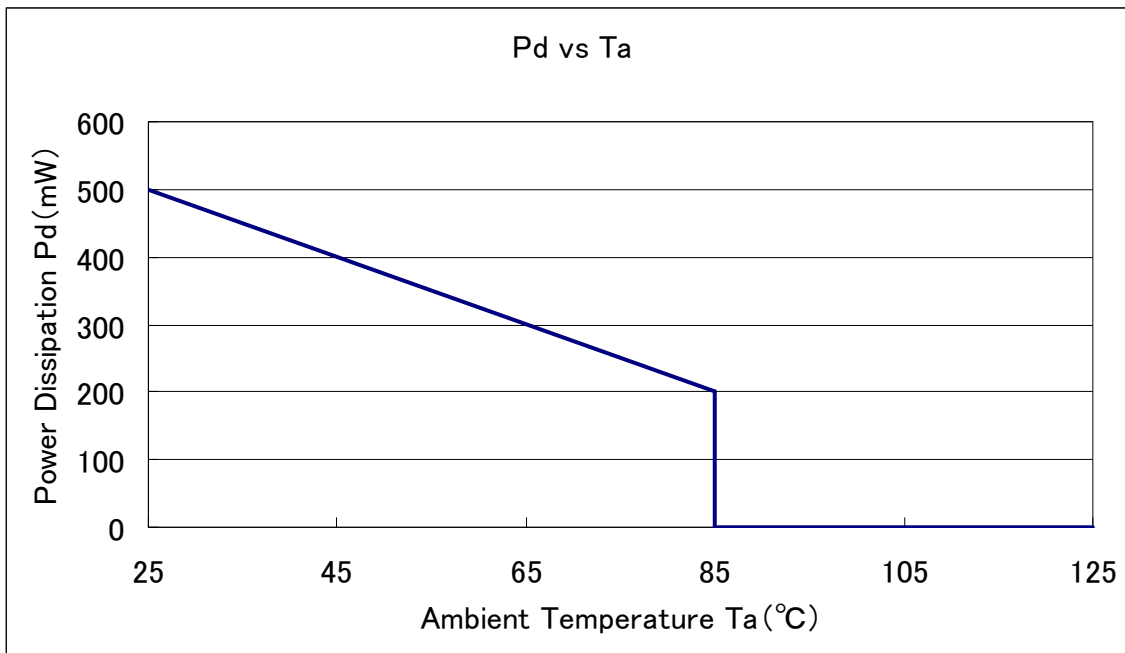

●SOT-89 Power Dissipation

Power dissipation data for the SOT-89 is shown in this page.
The value of power dissipation varies with the mount board conditions.
Please use this data as one of reference data taken in the described condition.

1. Measurement Condition (Reference data)

Condition : Mount on a board

Ambient : Natural convection

Soldering : Lead (Pb) free

Board : Dimensions 40×40mm (1600mm² in one side)

Copper (Cu) traces occupy 50% of the board area
In top and back faces

Package heat-sink is tied to the copper traces

Material : Glass Epoxy (FR-4)

Thickness : 1.6mm

Through-hole : 5 x 0.8 Diameter

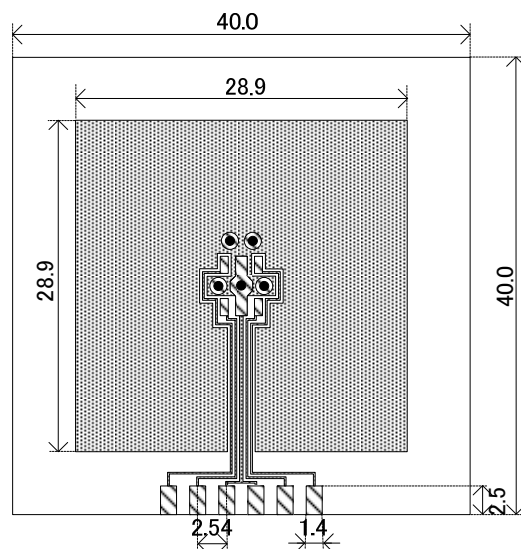

2. Power Dissipation vs. Ambient temperature

Board Mount (Tjmax=125°C)

Ambient Temperature (°C)	Power Dissipation Pd (mW)	Thermal Resistance (°C/W)
25	1000	100.00
85	400	

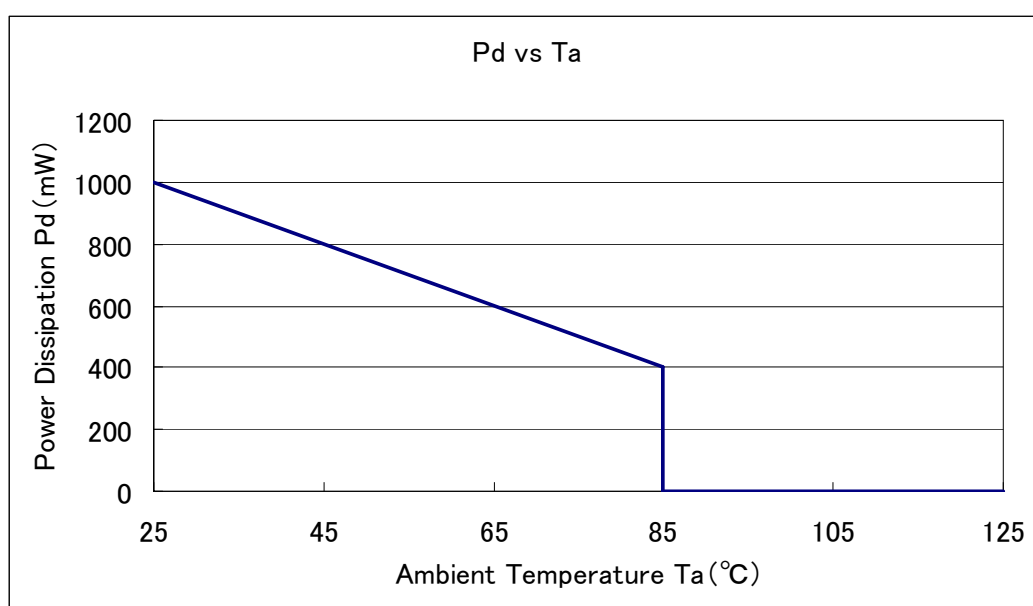

●USP-6C Power Dissipation

Power dissipation data for the USP-6C is shown in this page.
 The value of power dissipation varies with the mount board conditions.
 Please use this data as one of reference data taken in the described condition.

1. Measurement Condition (Reference data)

Condition : Mount on a board
 Ambient : Natural convection
 Soldering : Lead (Pb) free

Board : Dimensions 40mm×40mm (1600mm² in one side)

Copper (Cu) traces occupy 50% of the board area
 In top and back faces

Package heat-sink is tied to the copper traces

Material : Glass Epoxy (FR-4)

Thickness : 1.6mm

Through-hole : 4 x 0.8 Diameter

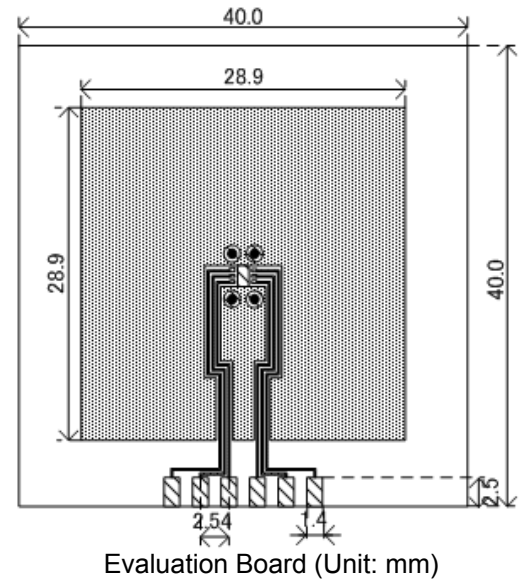

2. Power Dissipation vs. Ambient temperature (85°C)

Board Mount (Tjmax=125°C)

Ambient Temperature (°C)	Power Dissipation Pd (mW)	Thermal Resistance (°C/W)
25	1000	100.00
85	400	

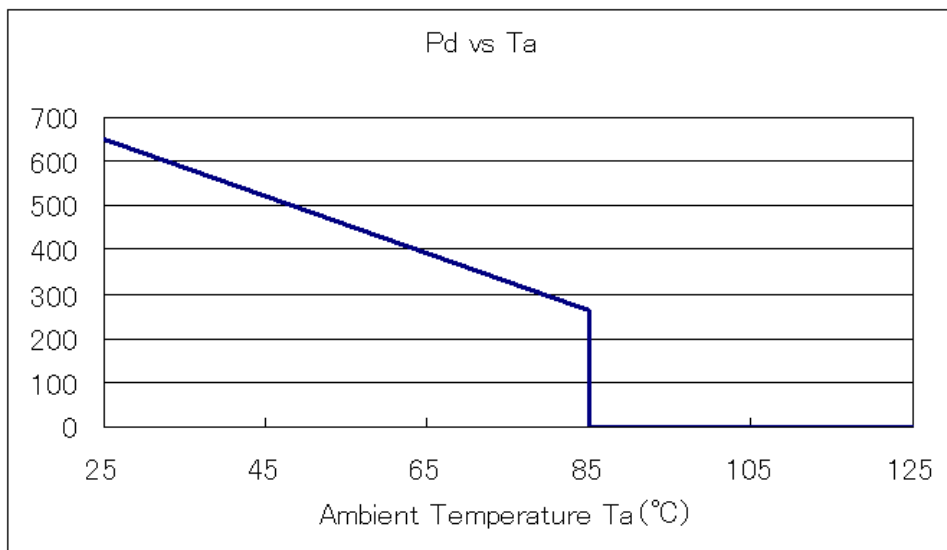

MARKING RULE

● SOT-23, SOT-89

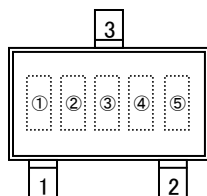

SOT-23

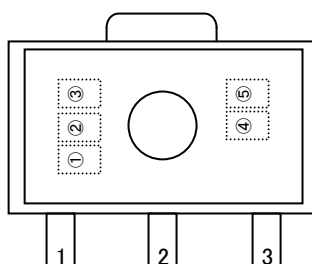

SOT-89

① represents product series

MARK	PRODUCT SERIES
E	XC6902xxxxxx-G

② represents output voltage range

MARK	VOLTAGE (V)	PRODUCT SERIES
A	-0.9 ~ -3.8	XC6902*091**-G ~ XC6902*381**-G
B	-3.9 ~ -6.8	XC6902*391**-G ~ XC6902*681**-G
C	-6.9 ~ -9.8	XC6902*691**-G ~ XC6902*981**-G
D	-9.9 ~ -12.0	XC6902*991**-G ~ XC6902*C01**-G

③ represents output voltage

MARK	OUTPUT VOLTAGE (V)				MARK	OUTPUT VOLTAGE (V)				MARK	OUTPUT VOLTAGE (V)			
0	-0.9	-3.9	-6.9	-9.9	A	-1.9	-4.9	-7.9	-10.9	N	-2.9	-5.9	-8.9	-11.9
1	-1.0	-4.0	-7.0	-10.0	B	-2.0	-5.0	-8.0	-11.0	P	-3.0	-6.0	-9.0	-12.0
2	-1.1	-4.1	-7.1	-10.1	C	-2.1	-5.1	-8.1	-11.1	R	-3.1	-6.1	-9.1	-
3	-1.2	-4.2	-7.2	-10.2	D	-2.2	-5.2	-8.2	-11.2	S	-3.2	-6.2	-9.2	-
4	-1.3	-4.3	-7.3	-10.3	E	-2.3	-5.3	-8.3	-11.3	T	-3.3	-6.3	-9.3	-
5	-1.4	-4.4	-7.4	-10.4	F	-2.4	-5.4	-8.4	-11.4	U	-3.4	-6.4	-9.4	-
6	-1.5	-4.5	-7.5	-10.5	H	-2.5	-5.5	-8.5	-11.5	V	-3.5	-6.5	-9.5	-
7	-1.6	-4.6	-7.6	-10.6	K	-2.6	-5.6	-8.6	-11.6	X	-3.6	-6.6	-9.6	-
8	-1.7	-4.7	-7.7	-10.7	L	-2.7	-5.7	-8.7	-11.7	Y	-3.7	-6.7	-9.7	-
9	-1.8	-4.8	-7.8	-10.8	M	-2.8	-5.8	-8.8	-11.8	Z	-3.8	-6.8	-9.8	-

④⑤ represents production lot number

01~09, 0A~0Z, 11~9Z, A1~A9, AA~AZ, B1~ZZ repeated.

(G, I, J, O, Q, W excluded.)

* No character inversion used.

MARKING RULE

● USP-6C

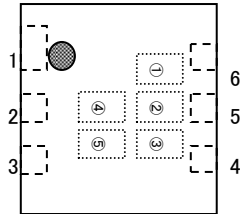

USP-6C

① represents product series

MARK	PRODUCT SERIES
T	XC6902xxxxxx-G

② represents output voltage range

MARK	VOLTAGE (V)	PRODUCT SERIES
A	-0.9 ~ -3.8	XC6902*091**-G ~ XC6902*381**-G
B	-3.9 ~ -6.8	XC6902*391**-G ~ XC6902*681**-G
C	-6.9 ~ -9.8	XC6902*691**-G ~ XC6902*981**-G
D	-9.9 ~ -12.0	XC6902*991**-G ~ XC6902*C01**-G

③ represents output voltage

MARK	OUTPUT VOLTAGE (V)				MARK	OUTPUT VOLTAGE (V)				MARK	OUTPUT VOLTAGE (V)			
0	-0.9	-3.9	-6.9	-9.9	A	-1.9	-4.9	-7.9	-10.9	N	-2.9	-5.9	-8.9	-11.9
1	-1.0	-4.0	-7.0	-10.0	B	-2.0	-5.0	-8.0	-11.0	P	-3.0	-6.0	-9.0	-12.0
2	-1.1	-4.1	-7.1	-10.1	C	-2.1	-5.1	-8.1	-11.1	R	-3.1	-6.1	-9.1	-
3	-1.2	-4.2	-7.2	-10.2	D	-2.2	-5.2	-8.2	-11.2	S	-3.2	-6.2	-9.2	-
4	-1.3	-4.3	-7.3	-10.3	E	-2.3	-5.3	-8.3	-11.3	T	-3.3	-6.3	-9.3	-
5	-1.4	-4.4	-7.4	-10.4	F	-2.4	-5.4	-8.4	-11.4	U	-3.4	-6.4	-9.4	-
6	-1.5	-4.5	-7.5	-10.5	H	-2.5	-5.5	-8.5	-11.5	V	-3.5	-6.5	-9.5	-
7	-1.6	-4.6	-7.6	-10.6	K	-2.6	-5.6	-8.6	-11.6	X	-3.6	-6.6	-9.6	-
8	-1.7	-4.7	-7.7	-10.7	L	-2.7	-5.7	-8.7	-11.7	Y	-3.7	-6.7	-9.7	-
9	-1.8	-4.8	-7.8	-10.8	M	-2.8	-5.8	-8.8	-11.8	Z	-3.8	-6.8	-9.8	-

④⑤ represents production lot number

01~09, 0A~0Z, 11~9Z, A1~A9, AA~AZ, B1~ZZ repeated.

(G, I, J, O, Q, W excluded.)

* No character inversion used.

1. The products and product specifications contained herein are subject to change without notice to improve performance characteristics. Consult us, or our representatives before use, to confirm that the information in this datasheet is up to date.
2. We assume no responsibility for any infringement of patents, patent rights, or other rights arising from the use of any information and circuitry in this datasheet.
3. Please ensure suitable shipping controls (including fail-safe designs and aging protection) are in force for equipment employing products listed in this datasheet.
4. The products in this datasheet are not developed, designed, or approved for use with such equipment whose failure or malfunction can be reasonably expected to directly endanger the life of, or cause significant injury to, the user.
(e.g. Atomic energy; aerospace; transport; combustion and associated safety equipment thereof.)
5. Please use the products listed in this datasheet within the specified ranges.
Should you wish to use the products under conditions exceeding the specifications, please consult us or our representatives.
6. We assume no responsibility for damage or loss due to abnormal use.
7. All rights reserved. No part of this datasheet may be copied or reproduced without the prior permission of TOREX SEMICONDUCTOR LTD.

TOREX SEMICONDUCTOR LTD.