

PART NUMBER	SML-LXL8047USBCTR3	REV.	
DATE	E.C.N. NUMBER AND REVISION COMMENTS		REV.
06.15.10	E.C.N. #: 11647 & REDRAWN		A

ELECTRO-OPTICAL CHARACTERISTICS $T_A=25^{\circ}\text{C}$ $I_f=700\text{mA}$

PARAMETER	MIN	TYP	MAX	UNITS	TEST COND
DOM. WAVELENGTH		454		nm	
FORWARD VOLTAGE	4.0	4.6	5.2	V_f	$I_f = 700\text{mA}$
REVERSE VOLTAGE	5.0			V_r	$I_r = 100\mu\text{A}$
AXIAL INTENSITY	17	20	29	lm	$I_f = 700\text{mA}$
VIEWING ANGLE		100		2x theta	
EMITTED COLOR:	BLUE				
EPOXY LENS FINISH:	WATER CLEAR				

LIMITS OF SAFE OPERATION AT 25°C

PARAMETER	MAX	UNITS
PEAK FORWARD CURRENT*	1000	mA
STEADY CURRENT	700	mA
LED JUNCTION TEMPERATURE	130	°C
DERATE FROM 25°C	-1.2	mW/°C
OPERATING, STORAGE TEMP.	-40 TO +100	°C

* $t < 10\mu\text{s}$

[A] NOTE:

- WE RECOMMEND THAT THE DEVICES MUST BE BAKED BEFORE SOLDERING IF THEY ARE REMOVED FROM THE ORIGINAL PACKAGE, AND ARE EXPOSED TO ENVIRONMENTAL CONDITIONS FOR LONGER THAN THE DURATIONS, (UNIT: DAYS) DEFINED IN THE TABLE BELOW.
- RECOMMENDED BAKING CONDITIONS ARE 24 HOURS AT 80°C

[A]

TEMPERATURE	MAXIMUM PERCENT RELATIVE HUMIDITY						
	30%	40%	50%	60%	70%	80%	90%
30°C	9	5	4	3	1	1	1
25°C	12	7	5	4	2	1	1
20°C	17	9	7	6	2	2	1

LEAD FREE REFLOW PROFILE

10 SEC. MAX.

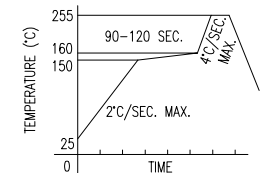

TOTAL TIME ABOVE 220°C IS 60 SECONDS MAX.

CAUTION: MOISTURE SENSITIVE DEVICE
PER JEDEC LEVEL 3 STANDARDS

CAUTION: STATIC SENSITIVE DEVICE
FOLLOW PROPER E.S.D. HANDLING PROCEDURES
WHEN WORKING WITH THIS PART.

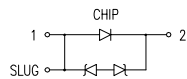
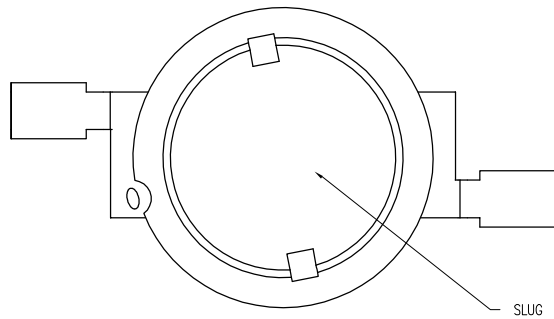
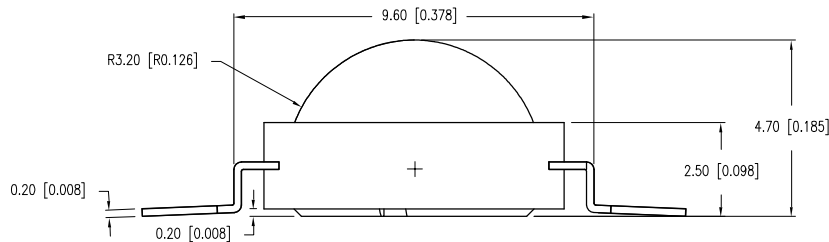
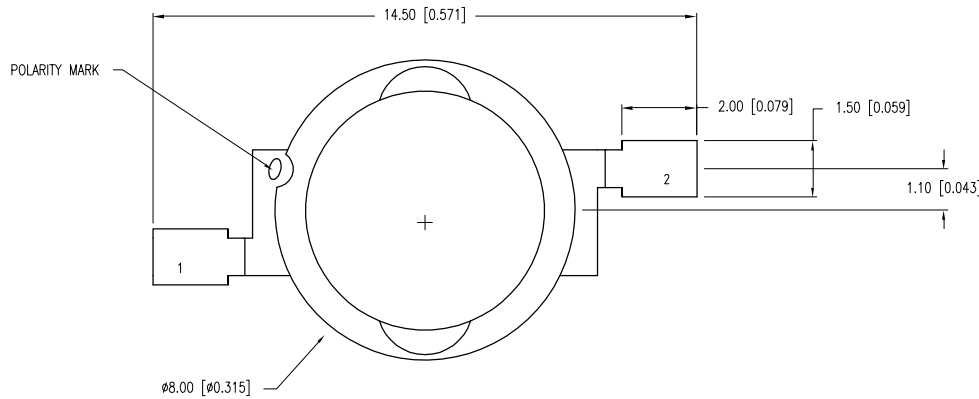

PAD LAYOUT

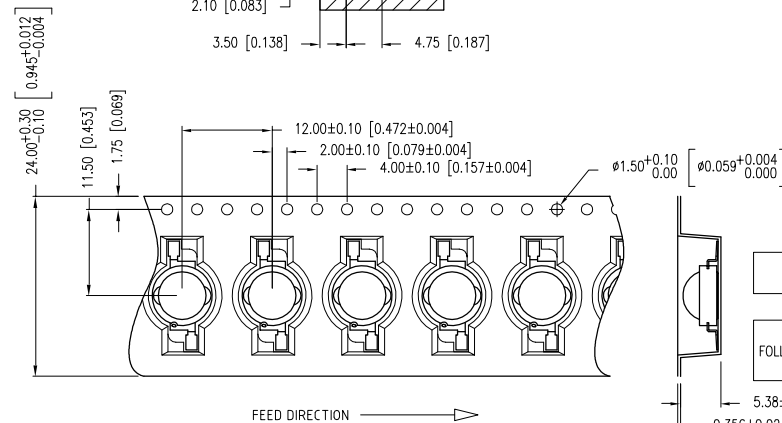
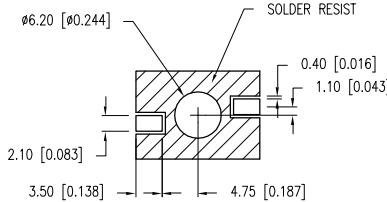

FEED DIRECTION

*UNLESS OTHERWISE SPECIFIED TOLERANCES PER DECIMAL PRECISION ARE: X=±1 (±0.039), X.X=±0.5 (±0.020), X.XX=±0.25 (±0.010), X.XXX=±0.127 (±0.005). LEAD SIZE=±0.05 (±0.002), LEAD LENGTH=±0.75 (±0.030). MIN= ^{+DECIMAL PRECISION} _{-0.00} MAX.= ^{+0.00} _{-DECIMAL PRECISION}



290 E. HELEN ROAD
PALATINE, IL 60067-6976
PHONE: +1.847.359.2790
FAX: +1.847.359.6538
WEB: WWW.LUMEX.COM

8mm ROUND TOP DOME SMT HI POWER LED BLUE 3W.

THE SPECIFICATIONS MAY CHANGE AT ANY TIME WITHOUT NOTICE DUE TO NEW MATERIALS OR PRODUCT IMPROVEMENT.

CONFIDENTIAL INFORMATION
THE INFORMATION CONTAINED IN THIS DOCUMENT IS THE PROPERTY OF LUMEX INC. EXCEPT AS SPECIFICALLY AUTHORIZED IN WRITING BY LUMEX INC., THE HOLDER OF THIS DOCUMENT SHALL KEEP ALL INFORMATION CONTAINED HEREIN CONFIDENTIAL AND SHALL PROTECT SAME IN WHOLE OR IN PART FROM DISCLOSURE AND DISSEMINATION TO ALL THIRD PARTIES.

DATE:	03.12.10	DRAWN BY:	JN
PAGE:	1 OF 1	CHKD BY:	SS
SCALE:	N/A	APRVD BY:	KF
UNIT:	mm [INCH]		