

UNCONTROLLED DOCUMENT

PART NUMBER  
SSL-LX25783GD

REV.  
C

REV.	E.C.N. NUMBER AND REVISION COMMENTS	DATE
A	CHANGED PEAK WAVELENGTH.	9.23.92
B	UPDATED SPECS.	3.6.95
C	E.C.N. #10702.	1.10.01

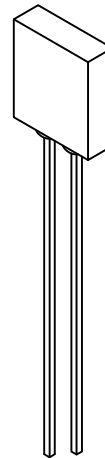
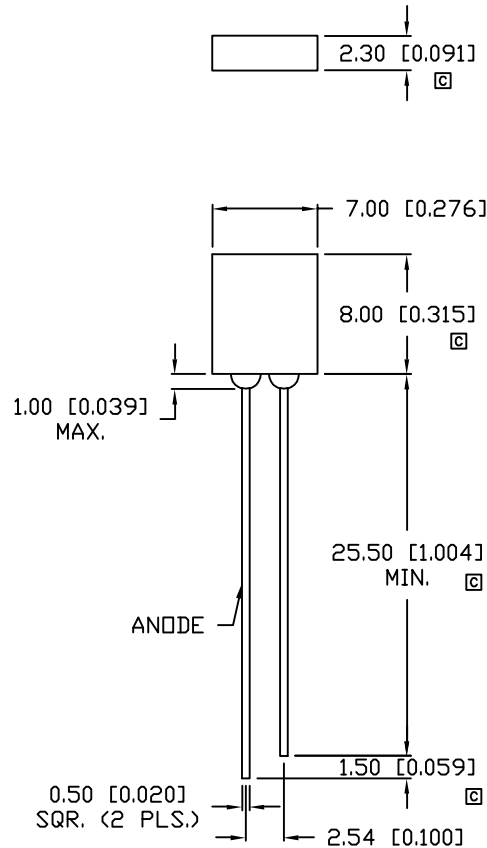

ELECTRO-OPTICAL CHARACTERISTICS  $T_A=25^\circ\text{C}$   $I_f=20\text{mA}$

PARAMETER	MIN	TYP	MAX	UNITS	TEST COND
PEAK WAVELENGTH		565		nm	
FORWARD VOLTAGE		2.0	2.8	$V_f$	
REVERSE VOLTAGE	5.0			$V_r$	$I_r=100\mu\text{A}$
AXIAL INTENSITY		9		mcd	$I_f=20\text{mA}$
VIEWING ANGLE		110		$2x$ theta	
EMITTED COLOR:	GREEN				
EPOXY LENS FINISH:	GREEN DIFFUSED				

LIMITS OF SAFE OPERATION AT  $25^\circ\text{C}$  PER DIE

PARAMETER	MAX	UNITS
PEAK FORWARD CURRENT*	150	mA
STEADY CURRENT	25	mA
POWER DISSIPATION	105	mW
DERATE FROM $25^\circ\text{C}$	-1.2	mW/ $^\circ\text{C}$
OPERATING, STORAGE TEMP.	-40 TO +85	$^\circ\text{C}$
SOLDERING TEMP.	+260	$^\circ\text{C}$
2.0mm FROM BODY		3 SEC. MAX

\*  $t < 10\mu\text{s}$

\*UNLESS OTHERWISE SPECIFIED TOLERANCES PER DECIMAL PRECISION ARE: X= $\pm 1$  ( $\pm 0.039$ ), X.X= $\pm 0.5$  ( $\pm 0.020$ ), X.XX= $\pm 0.25$  ( $\pm 0.010$ ), X.XXX= $\pm 0.127$  ( $\pm 0.005$ ). LEAD SIZE= $\pm 0.05$  ( $\pm 0.002$ ), LEAD LENGTH= $\pm 0.75$  ( $\pm 0.030$ ). MIN= +DECIMAL PRECISION -0.00, MAX= +0.00 -DECIMAL PRECISION

UNCONTROLLED DOCUMENT

REV. C	PART NUMBER SSL-LX25783GD
-----------	------------------------------

**CONFIDENTIAL INFORMATION**  
THE INFORMATION CONTAINED IN THIS DOCUMENT IS THE PROPERTY OF LUMEX INC. EXCEPT AS SPECIFICALLY AUTHORIZED IN WRITING BY LUMEX INC., THE HOLDER OF THIS DOCUMENT SHALL KEEP ALL INFORMATION CONTAINED HEREIN CONFIDENTIAL AND SHALL PROTECT SAME IN WHOLE OR IN PART FROM DISCLOSURE AND DISSEMINATION TO ALL THIRD PARTIES.



290 E. HELEN ROAD  
PALATINE, IL 60067-6976  
PHONE: +1.847.359.2790  
US WEB: www.lumex.com  
TW WEB: www.lumex.com.tw

2.3mm x 8mm RECTANGULAR LED, GREEN DIFFUSED.

**RELIABILITY NOTE**  
OUR MANY YEARS OF EXPERIENCE DATA ACCUMULATION INDICATE THAT SOLDER HEAT IS A MAJOR CAUSE OF EARLY AND FUTURE FAILURE. PLEASE PAY ATTENTION TO YOUR SOLDERING PROCESS.

DRAWN BY: CT	CHECKED BY:	APPROVED BY:	DATE: 4.26.90
			PAGE: 1 OF 1
			SCALE: N/A