

UNCONTROLLED DOCUMENT

PART NUMBER  
SSI-LXR1612GD-150

REV.  
D

REV.	E.C.N. NUMBER AND REVISION COMMENTS	DATE
A	CHG'D NOTE SIX TO SPECIFY BLACK INSUL.	3.2.93
B	UPDATED SAFE OPER. SPECS AND NOTES.	9.19.94
C	UPDATED DWG. & NOTES.	5.22.95
D	E.C.N. #10BRDR. & REDRAWN IN 3D.	10.16.01

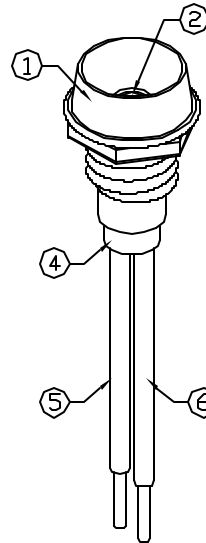
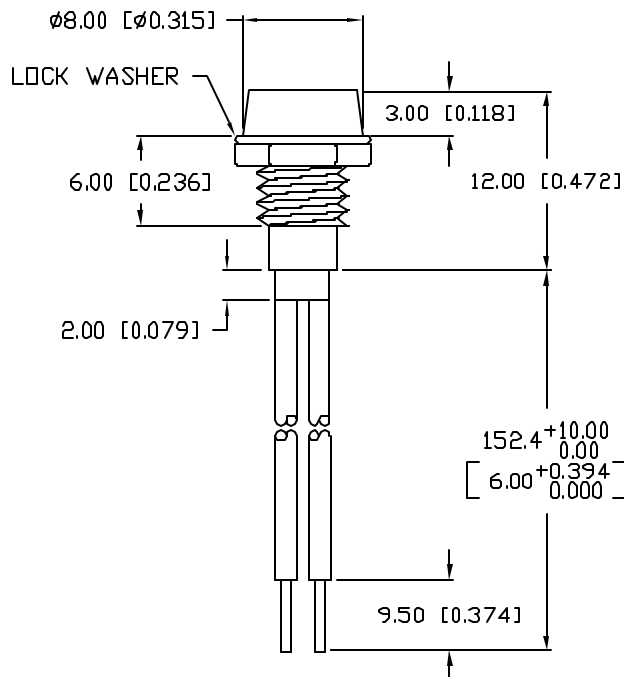

PANEL CUTOUT

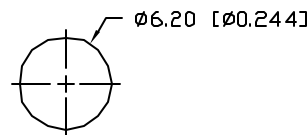

ELECTRO-OPTICAL CHARACTERISTICS  $T_A=25^\circ\text{C}$   $I_f=20\text{mA}$

PARAMETER	MIN	TYP	MAX	UNITS	TEST COND
PEAK WAVELENGTH		565		nm	
FORWARD VOLTAGE		2.2	2.6	V <sub>f</sub>	
REVERSE VOLTAGE	5.0			V <sub>r</sub>	I <sub>r</sub> =100μA
AXIAL INTENSITY		30		med	I <sub>f</sub> =20mA
VIEWING ANGLE		60		2x theta	
EMITTED COLOR:	GREEN				
EPOXY LENS FINISH:	GREEN DIFFUSED				

LIMITS OF SAFE OPERATION AT 25°C

PARAMETER	MAX	UNITS
PEAK FORWARD CURRENT*	150	mA
STEADY CURRENT	25	mA
POWER DISSIPATION	105	mW
DERATE FROM 25°C	-1.6	mW/°C
OPERATING, STORAGE TEMP.	-40 TO +85	°C
SOLDERING TEMP.	+260	°C
2.0mm FROM BODY		3 SEC. MAX

\*  $t < 10\mu\text{s}$

NOTES:

1. SSI-LXR1612, CHROME HOUSING.
2. SSL-LX3054GD, GREEN LED. TRIM LEADS TO 5mm.
3. SOLDER WIRE LEADS TO LED LEADS.
4. SSH-LXH1612BSG, BUSHING. INSERT AND CRIMP.
5. ANODE LEAD: LXP-WST26RDT0C, 26 AWG, STRANDED, RED INSULATION. CUT 157mm LONG, STRIP END 2mm & 9.5mm.
6. CATHODE LEAD: LXP-WST26BLT0C, 26 AWG, STRANDED, BLACK INSULATION. CUT 157mm LONG, STRIP END 2mm & 9.5mm.

UNCONTROLLED DOCUMENT

\*UNLESS OTHERWISE SPECIFIED TOLERANCES PER DECIMAL PRECISION ARE: X=±1 (±0.039), XX=±0.5 (±0.020), XXX=±0.25 (±0.010), XXXX=±0.127 (±0.005). LEAD SIZE=±0.05 (±0.002), LEAD LENGTH=±0.75 (±0.030), MIN.=<sup>+DECIMAL PRECISION</sup><sub>-0.00</sub> MAX.=<sup>+0.00</sup><sub>-DECIMAL PRECISION</sub>

REV.  
D

PART NUMBER  
SSI-LXR1612GD-150

CONFIDENTIAL INFORMATION  
THE INFORMATION CONTAINED IN THIS DOCUMENT IS THE PROPERTY OF LUMEX INC. EXCEPT AS SPECIFICALLY AUTHORIZED IN WRITING BY LUMEX INC, THE HOLDER OF THIS DOCUMENT SHALL KEEP ALL INFORMATION CONTAINED HEREIN CONFIDENTIAL AND SHALL PROTECT SAME IN WHOLE OR IN PART FROM DISCLOSURE AND DISSEMINATION TO ALL THIRD PARTIES.



290 E. HELEN ROAD  
PALATINE, IL 60067-6976  
PHONE: +1.847.359.2790  
US WEB: www.lumex.com  
TW WEB: www.lumex.com.tw

T-3mm (T-1) 565nm GREEN LED PANEL INDICATOR,  
GREEN DIFFUSED LENS, 6" WIRE LEADS.

RELIABILITY NOTE  
OUR MANY YEARS OF EXPERIENCE DATA ACCUMULATION INDICATE THAT SOLDER HEAT IS A MAJOR CAUSE OF EARLY AND FUTURE FAILURE. PLEASE PAY ATTENTION TO YOUR SOLDERING PROCESS.

DRAWN BY: BC	CHECKED BY:	APPROVED BY:	DATE: 6.3.92
			PAGE: 1 OF 1
			SCALE: N/A