

CAUTION: STATIC SENSITIVE DEVICE
FOLLOW PROPER E.S.D. HANDLING PROCEDURES
WHEN WORKING WITH THIS PART.

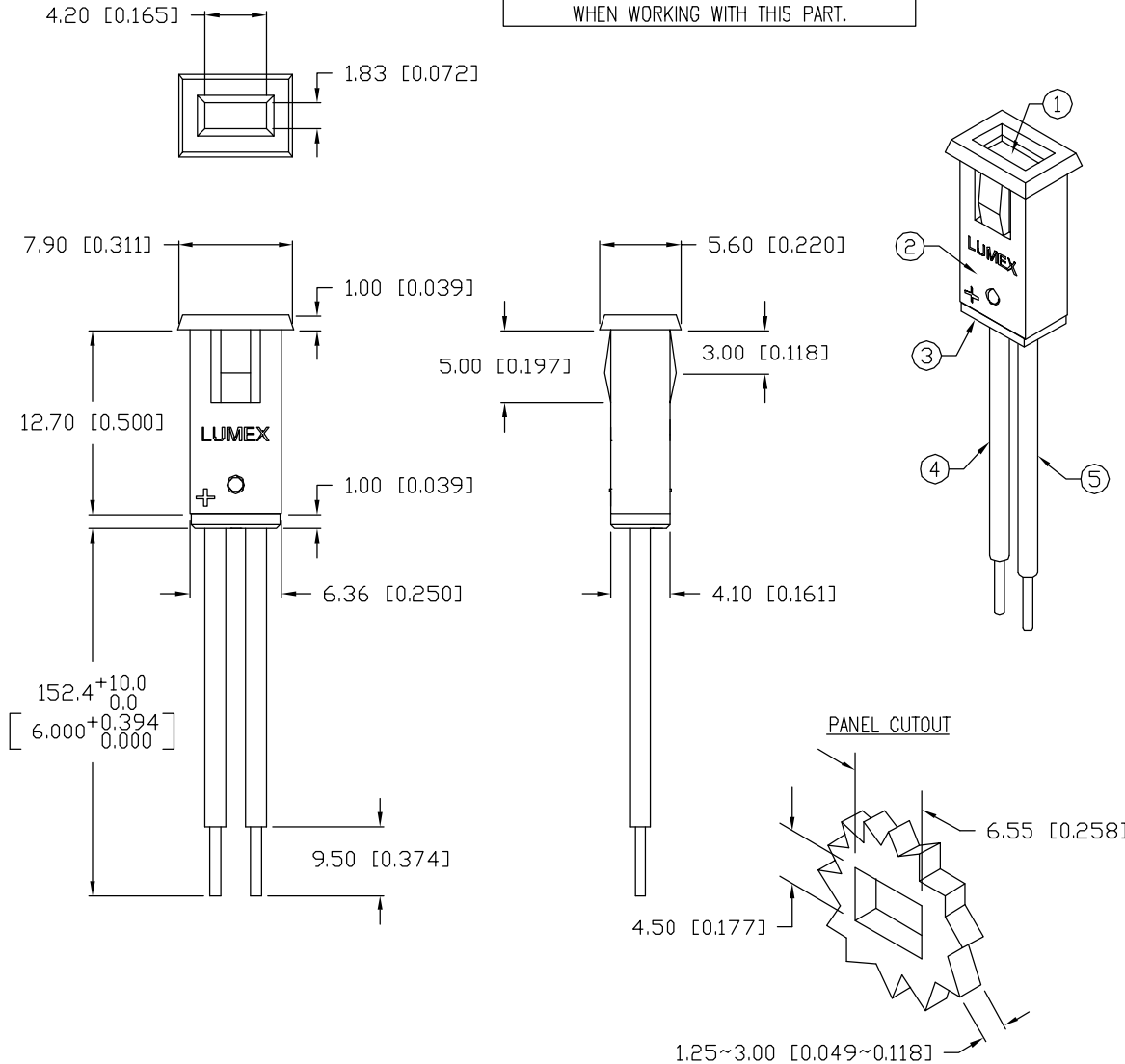

ELECTRO-OPTICAL CHARACTERISTICS $T_A=25^{\circ}\text{C}$ $I_f=20\text{mA}$

| PARAMETER | MIN | TYP | MAX | UNITS | TEST COND |
|--------------------|---------------|-----|-----|----------|----------------------|
| PEAK WAVELENGTH | | 470 | | nm | |
| FORWARD VOLTAGE | | 3.5 | 4.0 | V_f | |
| REVERSE VOLTAGE | 5.0 | | | V_r | $I_f=100\mu\text{A}$ |
| AXIAL INTENSITY | | 50 | | mcd | $I_f=20\text{mA}$ |
| VIEWING ANGLE | | 110 | | 2x theta | |
| EMITTED COLOR: | BLUE | | | | |
| EPOXY LENS FINISH: | BLUE DIFFUSED | | | | |

LIMITS OF SAFE OPERATION AT 25°C

| PARAMETER | MAX | UNITS |
|--------------------------|------------|-------|
| PEAK FORWARD CURRENT* | 100 | mA |
| STEADY CURRENT | 30 | mA |
| POWER DISSIPATION | 98 | mW |
| DERATE FROM 25°C | -1.2 | mW/°C |
| OPERATING, STORAGE TEMP. | -40 TO +85 | °C |

* $t < 10\mu\text{s}$

NOTES:

1. SSL-LX2573USBD, BLUE LED. TRIM LEADS TO 3~4mm LONG.
2. SSH-LXMP059-HSG, BLACK HOLDER.
3. SSH-LXMP059-BSG2, BUSHING.
4. ANODE LEAD: LXP-WST24RDT0C, RED INSULATED, 24 AWG., CUT 155mm, STRIP 3mm & 9.5mm.
5. CATHODE LEAD: LXP-WST24BLT0C, BLACK INSULATED, 24 AWG., CUT 155mm, STRIP 3mm & 9.5mm.
6. CRIMP OR SOLDER LEAD WIRES TO LED AND ASSEMBLE INTO HOUSING.

*UNLESS OTHERWISE SPECIFIED TOLERANCES PER DECIMAL PRECISION ARE: X=±1 (±0.039), X.X=±0.5 (±0.020), X.XX=±0.25 (±0.010), X.XXX=±0.127 (±0.005). LEAD SIZE=±0.05 (±0.002), LEAD LENGTH=±0.75 (±0.030). MIN.= +DECIMAL PRECISION MAX.= +0.00 -DECIMAL PRECISION

REV.

PART NUMBER

SSI-LXMP059USBD150

470nm InGaN/SiC BLUE RECTANGULAR LED PANEL INDICATOR,
BLUE DIFFUSED LENS, 6" WIRE LEADS.

CONFIDENTIAL INFORMATION

THE INFORMATION CONTAINED IN THIS DOCUMENT IS THE PROPERTY OF LUMEX INC. EXCEPT AS SPECIFICALLY AUTHORIZED IN WRITING BY LUMEX INC., THE HOLDER OF THIS DOCUMENT SHALL KEEP ALL INFORMATION CONTAINED HEREIN CONFIDENTIAL AND SHALL PROTECT SAME IN WHOLE OR IN PART FROM DISCLOSURE AND DISSEMINATION TO ALL THIRD PARTIES.

RELIABILITY NOTE

OUR MANY YEARS OF EXPERIENCE DATA ACCUMULATION INDICATE THAT SOLDER HEAT IS A MAJOR CAUSE OF EARLY AND FUTURE FAILURE. PLEASE PAY ATTENTION TO YOUR SOLDERING PROCESS.



290 E. HELEN ROAD
PALATINE, IL 60067-6976
PHONE: +1.847.359.2790
US WEB: www.lumex.com
TW WEB: www.lumex.com.tw

| | | | |
|-----------------|-------------|--------------|--------------|
| DRAWN BY: BC | CHECKED BY: | APPROVED BY: | DATE: 1.7.02 |
| | | | PAGE: 1 OF 1 |
| | | | SCALE: N/A |