

PART NUMBER <b>LDS-AA406RI</b>		REV.
REV.	E.C.N. NUMBER AND REVISION COMMENTS	DATE

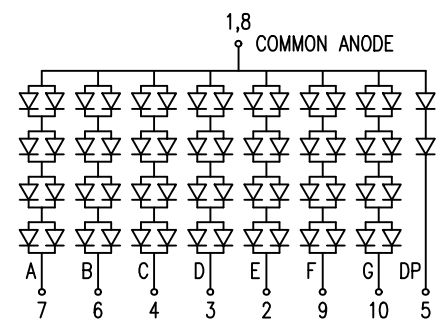
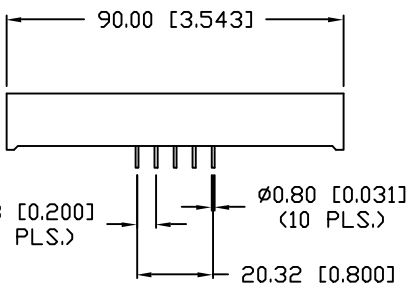
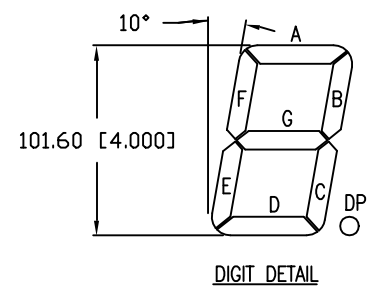
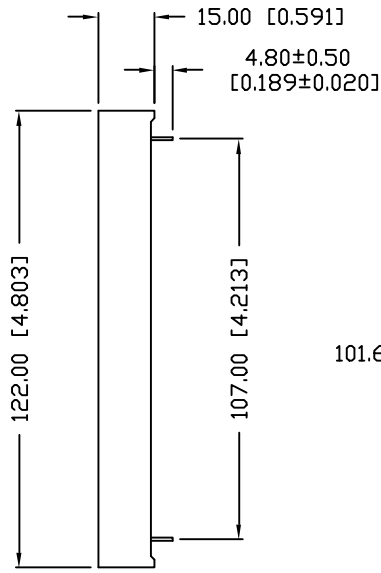
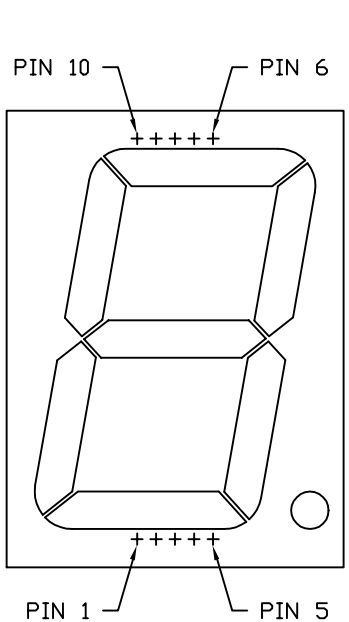

ELECTRO-OPTICAL CHARACTERISTICS  $T_A=25^\circ\text{C}$   $I_f=10\text{mA}$

PARAMETER	MIN	TYP	MAX	UNITS	TEST COND
PEAK WAVELENGTH		660 (RED)		nm	
FORWARD VOLTAGE*		7.2/3.6	9.2/4.6	$V_f$	
REVERSE VOLTAGE	4.0			$V_r$	$I_r=100\mu\text{A}$
AXIAL INTENSITY		20,000		$\mu\text{cd}$	$I_f=10\text{mA}$
EMITTED COLOR:	SUPER RED				
FACE COLOR:	GRAY				
SEGMENT COLOR:	MILKY WHITE DIFFUSED				

\* SECOND VALUE FOR TWO CHIPS IN DECIMAL POINT.

LIMITS OF SAFE OPERATION AT 25°C PER DIE

PARAMETER	MAX	UNITS
PEAK FORWARD CURRENT*	150	mA
STEADY CURRENT	30	mA
POWER DISSIPATION	100	mW
DERATE FROM 25°C	-1.2	mW/°C
OPERATING, STORAGE TEMP.	-20 TO +80	°C
SOLDERING TEMP.	+260	°C
2.0mm FROM BODY		3 SEC. MAX

\*  $t < 10\mu\text{s}$

REV.	PART NUMBER <b>LDS-AA406RI</b>
4.0" SINGLE DIGIT, SEVEN SEGMENT DISPLAY, 660nm SUPER RED CHIPS, GRAY FACE, MILKY WHITE DIFFUSED SEGMENTS, COMMON ANODE.	

**CONFIDENTIAL INFORMATION**  
THE INFORMATION CONTAINED IN THIS DOCUMENT IS THE PROPERTY OF LUMEX INC. EXCEPT AS SPECIFICALLY AUTHORIZED IN WRITING BY LUMEX INC., THE HOLDER OF THIS DOCUMENT SHALL KEEP ALL INFORMATION CONTAINED HEREIN CONFIDENTIAL AND SHALL PROTECT SAME IN WHOLE OR IN PART FROM DISCLOSURE AND DISSEMINATION TO ALL THIRD PARTIES.

**RELIABILITY NOTE**  
OUR MANY YEARS OF EXPERIENCE DATA ACCUMULATION INDICATE THAT SOLDER HEAT IS A MAJOR CAUSE OF EARLY AND FUTURE FAILURE. PLEASE PAY ATTENTION TO YOUR SOLDERING PROCESS.

**LUMEX INCORPORATED**  
290 E. HELLEN ROAD  
PALATINE, ILLINOIS 60067  
PHONE: 1-847-359-2790  
WEB: HTTP://WWW.LUMEX.COM

DRAWN BY:	CHECKED BY:	APPROVED BY:	DATE: 10-19-99
TM/DU			PAGE: 1 OF 1 SCALE: N/A