

UNCONTROLLED DOCUMENT

PART NUMBER
SSL-LXA228GC-TR21

REV.
C

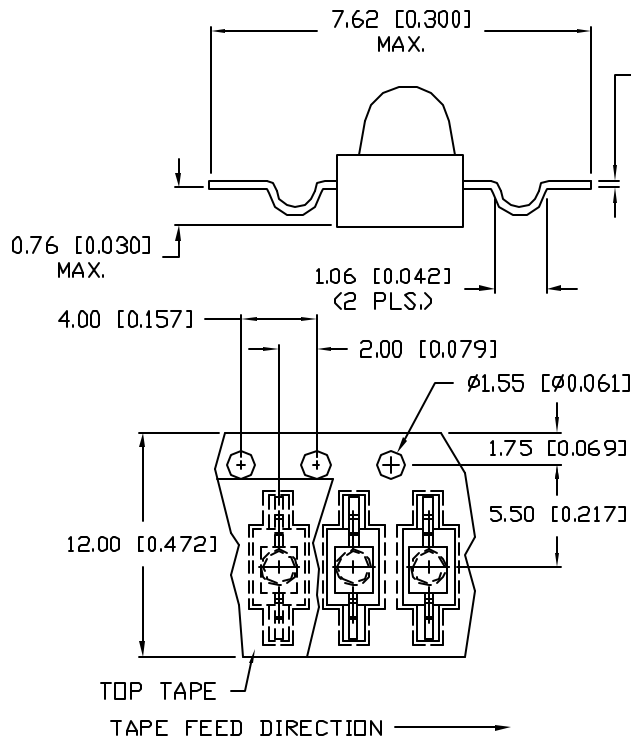
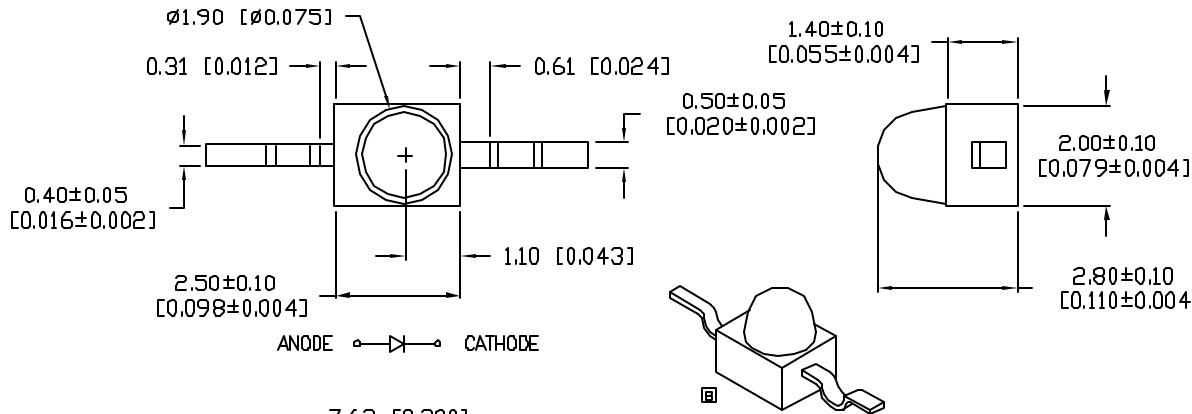

0.15±0.02
[0.006±0.001]

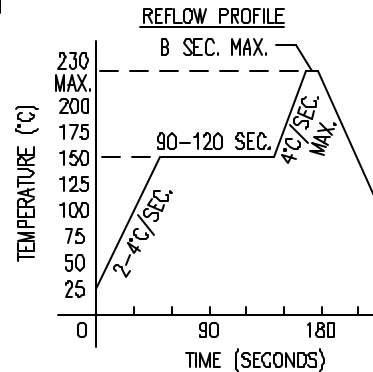

RECOMMENDED SOLDER PAD LAYOUT

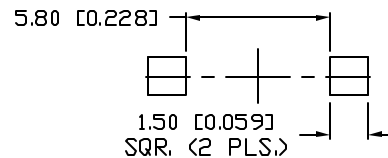

| REV. | E.C.N. NUMBER AND REVISION COMMENTS | DATE |
|------|-------------------------------------|----------|
| A | CHG'D WHERE NOTED. | 11.29.94 |
| B | E.C.N. #10695. | 1.5.01 |
| C | E.C.N. #11148 | 11.14.06 |

ELECTRO-OPTICAL CHARACTERISTICS $T_A=25^\circ\text{C}$ $I_f=20\text{mA}$

| PARAMETER | MIN | TYP | MAX | UNITS | TEST COND |
|--------------------|-------------|-----|-----|----------|----------------------|
| PEAK WAVELENGTH | | 565 | | nm | |
| FORWARD VOLTAGE | | 2.1 | 2.8 | V_f | |
| REVERSE VOLTAGE | 5.0 | | | V_r | $I_f=100\mu\text{A}$ |
| AXIAL INTENSITY | | 30 | | mcd | $I_f=20\text{mA}$ |
| VIEWING ANGLE | | 25 | | 2x theta | |
| EMITTED COLOR: | GREEN | | | | |
| EPOXY LENS FINISH: | WATER CLEAR | | | | |

LIMITS OF SAFE OPERATION AT 25°C

| PARAMETER | MAX | UNITS |
|--------------------------|------------|-------|
| PEAK FORWARD CURRENT* | 160 | mA |
| STEADY CURRENT | 30 | mA |
| POWER DISSIPATION | 100 | mW |
| DERATE FROM 25°C | -1.2 | mW/°C |
| OPERATING, STORAGE TEMP. | -40 TO +85 | °C |

* $t < 10\mu\text{s}$

NOTES:

- 1,000 PIECES PER REEL
- THE CATHODE IS ORIENTED TOWARDS THE TAPE SPROCKET HOLE.



*UNLESS OTHERWISE SPECIFIED TOLERANCES PER DECIMAL PRECISION ARE: X=±1 (±0.038), XX=±0.5 (±0.020), XXX=±0.25 (±0.010), XXXX=±0.127 (±0.005). LEAD SIZE=±0.05 (±0.002), LEAD LENGTH=±0.75 (±0.030), MIN=+DECIMAL PRECISION MAX=-DECIMAL PRECISION

| | | | |
|------------------------------------------------------------|----------------------------------|---------------------------------------------------------------------------------------------------------------------------------------------------------------------------------------------------------------------------------------------------------------------------------------------------------------------------------------------------------|-----------------------------------------------------------------------------------------------------------------------------|
| REV. C | PART NUMBER SSL-LXA228GC-TR21 | CONFIDENTIAL INFORMATION THE INFORMATION CONTAINED IN THIS DOCUMENT IS THE PROPERTY OF LUMEX INC. EXCEPT AS SPECIFICALLY AUTHORIZED IN WRITING BY LUMEX INC, THE HOLDER OF THIS DOCUMENT SHALL KEEP ALL INFORMATION CONTAINED HEREIN CONFIDENTIAL AND SHALL PROTECT SAME IN WHOLE OR IN PART FROM DISCLOSURE AND DISSEMINATION TO ALL THIRD PARTIES. | 290 E. HELEN ROAD PALATINE, IL 60067-6976 PHONE: +1.847.359.2790 US WEB: www.lumex.com TW WEB: www.lumex.com.tw |
| 565nm GREEN AXIAL LEADED LED, YOKE LEAD, TAPE AND REEL. | | RELIABILITY NOTE OUR MANY YEARS OF EXPERIENCE DATA ACCUMULATION INDICATE THAT SOLDER HEAT IS A MAJOR CAUSE OF EARLY AND FUTURE FAILURE. PLEASE PAY ATTENTION TO YOUR SOLDERING PROCESS. | DRAWN BY: JC CHECKED BY: APPROVED BY: DATE: 11.14.06 PAGE: 1 OF 1 SCALE: N/A |

UNCONTROLLED DOCUMENT