

PART NUMBER	SML-LX2832GC-TR	REV.	E
DATE	E.C.N. NUMBER AND REVISION COMMENTS		REV.
03.14.03	E.C.N. #10967.		A
02.08.05	E.C.N. #11148.		B
03.16.07	E.C.N. #11402.		C
10.17.07	E.C.N. #11450.		D
05.04.10	E.C.N. #11627.		E

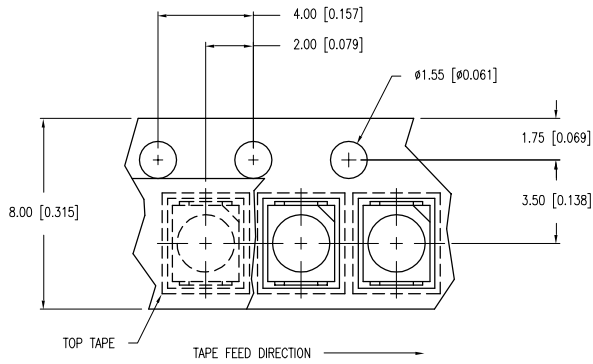

RECOMMENDED SOLDER PAD LAYOUT

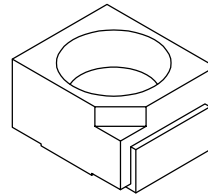
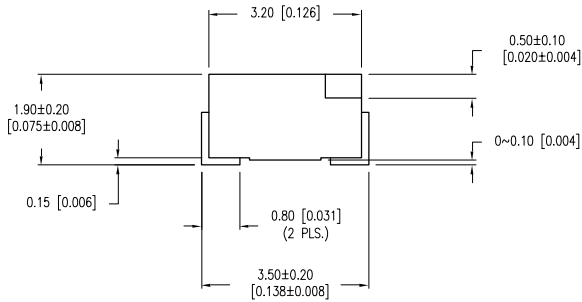
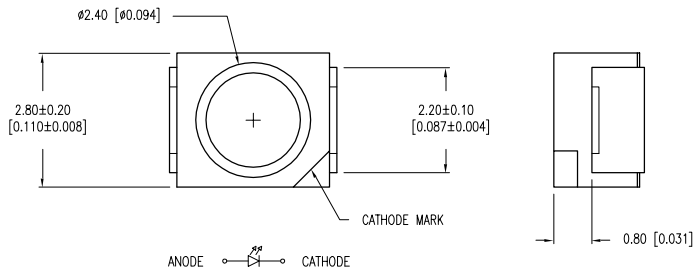
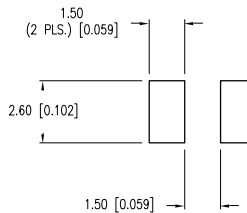

ELECTRO-OPTICAL CHARACTERISTICS  $T_A=25^\circ\text{C}$   $I_f=20\text{mA}$

PARAMETER	MIN	TYP	MAX	UNITS	TEST COND
PEAK WAVELENGTH		565		nm	
FORWARD VOLTAGE		2.1	2.8	V <sub>f</sub>	
REVERSE VOLTAGE	5			V <sub>r</sub>	I <sub>r</sub> = 100µA
AXIAL INTENSITY	10	25		mcd	I <sub>f</sub> = 20mA
VIEWING ANGLE		120		2x theta	
EMITTED COLOR:	GREEN				
EPOXY LENS FINISH:	WATER CLEAR				

LIMITS OF SAFE OPERATION AT 25°C

PARAMETER	MAX	UNITS
PEAK FORWARD CURRENT*	160	mA
STEADY CURRENT	25	mA
POWER DISSIPATION	100	mW
DERATE FROM 25°C	- 1.2	mW/°C
OPERATING TEMP.	-40 TO +85	°C
STORAGE TEMP.	-40 TO +85	°C
SOLDERING TEMP.	+260	°C
2.0mm FROM BODY	3	SEC. MAX

\* t < 10µs

LEAD FREE REFLOW PROFILE  
10 SEC. MAX.

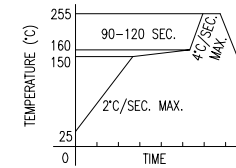

TOTAL TIME ABOVE 220°C IS 60 SECONDS MAX.

NOTES:

- THE POLARITY MARK IS ORIENTED TOWARDS THE TAPE SPROCKET HOLE.

CAUTION: MOISTURE SENSITIVE DEVICE PER JEDEC LEVEL 2 STANDARDS

\*UNLESS OTHERWISE SPECIFIED TOLERANCES PER DECIMAL PRECISION ARE: X=±1 (±0.039), X.X=±0.5 (±0.020), X.XX=±0.25 (±0.010), X.XXX=±0.127 (±0.005). LEAD SIZE=±0.05 (±0.002), LEAD LENGTH=±0.75 (±0.030), MIN.= +DECIMAL PRECISION -0.00, MAX.= +0.00 -DECIMAL PRECISION UNCONTROLLED DOCUMENT



290 E. HELEN ROAD  
PALATINE, IL 60067-6976  
PHONE: +1.847.359.2790  
FAX: +1.847.359.6538  
WEB: WWW.LUMEX.COM

2.8mm X 3.2mm SML /W REFLECTOR, 565nm LED, WATER CLEAR LENS, 2,000 PCS PER TAPE & REEL.

\*\*THE SPECIFICATIONS MAY CHANGE AT ANY TIME WITHOUT NOTICE DUE TO NEW MATERIALS OR PRODUCT IMPROVEMENT.\*\*

CONFIDENTIAL INFORMATION  
THE INFORMATION CONTAINED IN THIS DOCUMENT IS THE PROPERTY OF LUMEX INC. EXCEPT AS SPECIFICALLY AUTHORIZED IN WRITING BY LUMEX INC., THE HOLDER OF THIS DOCUMENT SHALL KEEP ALL INFORMATION CONTAINED HEREIN CONFIDENTIAL AND SHALL PROTECT SAME IN WHOLE OR IN PART FROM DISCLOSURE AND DISSEMINATION TO ALL THIRD PARTIES.

DATE:	01.11.01	DRAWN BY:	JC
PAGE:	1 OF 1	CHKD BY:	SS
SCALE:	N/A	APRVD BY:	KF
UNIT:	mm [INCH]		