

\* PATENT PENDING

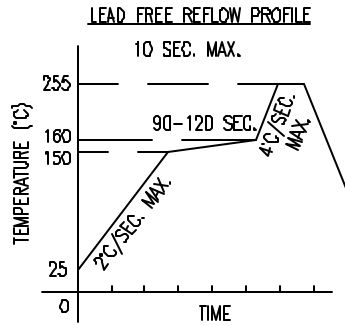

TOTAL TIME ABOVE 220°C IS 60 SECONDS MAX.

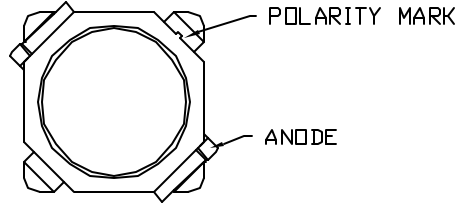
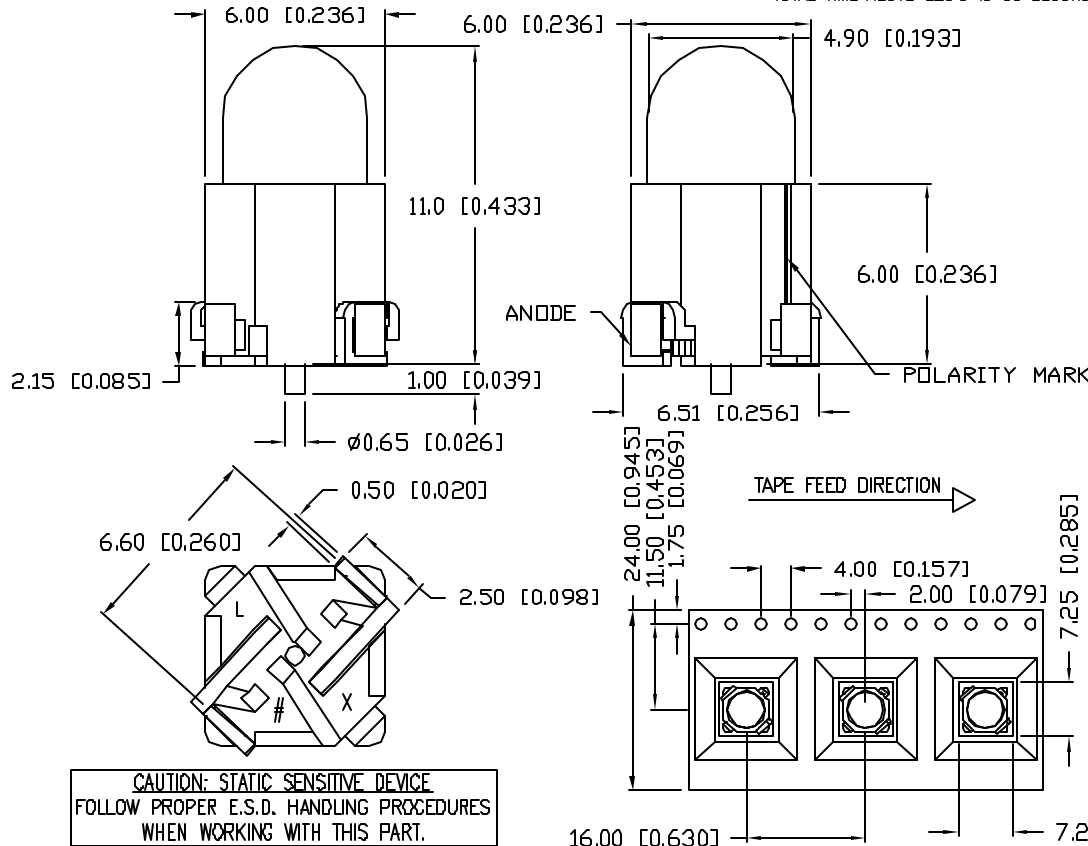

CAUTION: STATIC SENSITIVE DEVICE  
FOLLOW PROPER E.S.D. HANDLING PROCEDURES  
WHEN WORKING WITH THIS PART.

PART NUMBER	REV.
SML-H1505UWC-TR	

ELECTRO-OPTICAL CHARACTERISTICS  $T_A=25^\circ\text{C}$   $I_f=20\text{MA}$

PARAMETER	MIN	TYP	MAX	UNITS	TEST COND
FORWARD VOLTAGE		3.3	4.0	$V_f$	
REVERSE VOLTAGE	5.0			$V_r$	$I_f=100\mu\text{A}$
AXIAL INTENSITY	7000	14000		mcd	$I_f=20\text{MA}$
CHROMATICITY X	0.2020	-	0.3622		$I_f=20\text{mA}$
COORDINATES(*1)Y	0.1530	-	0.3939		
VIEWING ANGLE		30			2x theta
EMITTED COLOR:	WHITE				
EPOXY LENS FINISH:	WATER CLEAR				

\*1. THE ICI STANDARD COLORIMETRIC SYSTEM.  
LIMITS OF SAFE OPERATION AT 25°C PER DIE

PARAMETER	MAX	UNITS
PEAK FORWARD CURRENT*	100	mA
STEADY CURRENT	20	mA
POWER DISSIPATION	80	mW
DERATE FROM 25°C	-1.2	mW/°C
OPERATING TEMP.	-20 TO +80	°C
STORAGE TEMP.	-30 TO +100	°C
SOLDERING TEMP.	+260	°C
2.0mm FROM BODY		5 SEC. MAX

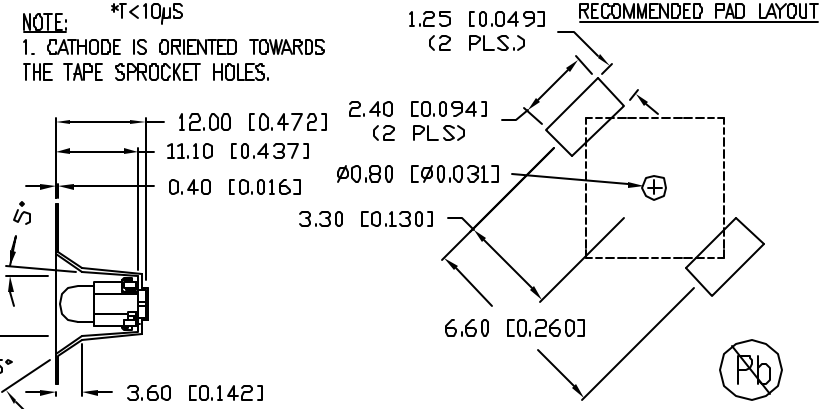

\*UNLESS OTHERWISE SPECIFIED TOLERANCES PER DECIMAL PRECISION ARE: X=±1 (±0.039), XX=±0.5 (±0.020), XXX=±0.25 (±0.010), XXXX=±0.127 (±0.005), LEAD SIZE=±0.05 (±0.002), LEAD LENGTH=±0.75 (±0.030). MIN.=+DECIMAL PRECISION -0.00, MAX.=+0.00 -DECIMAL PRECISION

REV.	PART NUMBER
	SML-H1505UWC-TR
5mm SURFACE MOUNTED DOME LED, ULTRA WHITE LED, WATER CLEAR.	

CONFIDENTIAL INFORMATION  
THE INFORMATION CONTAINED IN THIS DOCUMENT IS THE PROPERTY OF LUMEX INC. EXCEPT AS SPECIFICALLY AUTHORIZED IN WRITING BY LUMEX INC., THE HOLDER OF THIS DOCUMENT SHALL KEEP ALL INFORMATION CONTAINED HEREIN CONFIDENTIAL AND SHALL PROTECT SAME IN WHOLE OR IN PART FROM DISCLOSURE AND DISSEMINATION TO ALL THIRD PARTIES.

RELIABILITY NOTE  
OUR MANY YEARS OF EXPERIENCE DATA ACCUMULATION INDICATE THAT SOLDER HEAT IS A MAJOR CAUSE OF EARLY AND FUTURE FAILURE. PLEASE PAY ATTENTION TO YOUR SOLDERING PROCESS.

		290 E. HELEN ROAD PALATINE, IL 60067-6976 PHONE: +1.847.359.2790 US WEB: www.lumex.com TW WEB: www.lumex.com.tw
DRAWN BY:	CHECKED BY:	APPROVED BY:
JN		
DATE: 04.25.08		PAGE: 1 OF 1
SCALE: N/A		