

UNCONTROLLED DOCUMENT

PART NUMBER
SSA-LXB525ID

REV.
D

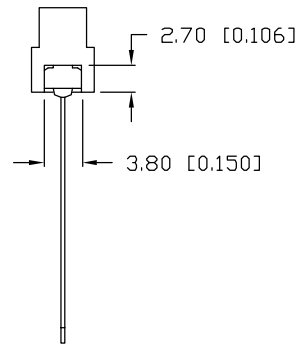
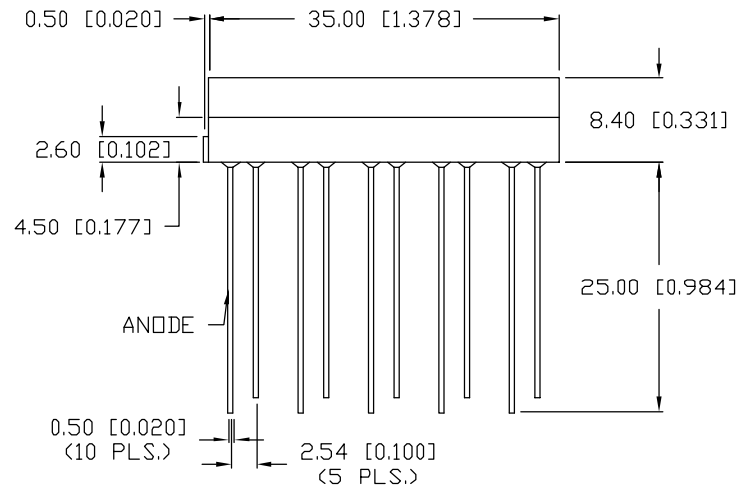
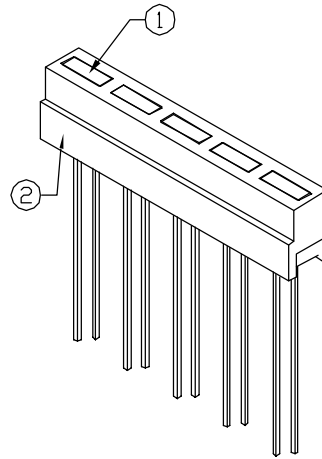
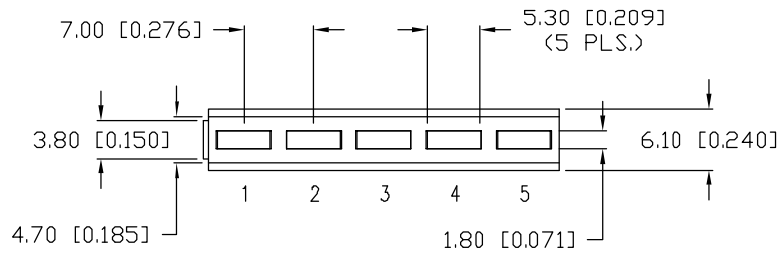

REV.	E.C.N. NUMBER AND REVISION COMMENTS	DATE
A	REDRAWN. ADDED B.O.M.	11.25.92
B	REDRAWN. UPDATED SPECS.	5.22.95
C	E.C.N. #10210.	7.17.96
D	E.C.N. #10BRDR. & REDRAWN.	6.4.01

ELECTRO-OPTICAL CHARACTERISTICS $T_A=25^{\circ}\text{C}$ $I_f=20\text{mA}$

PARAMETER	MIN	TYP	MAX	UNITS	TEST COND
PEAK WAVELENGTH		635		nm	
FORWARD VOLTAGE		2.0	2.5	V_f	
REVERSE VOLTAGE	5.0			V_r	$I_f=100\mu\text{A}$
AXIAL INTENSITY		12		mcd	$I_f=20\text{mA}$
VIEWING ANGLE		110		2x theta	
EMITTED COLOR:	RED				
EPOXY LENS FINISH:	RED DIFFUSED				

▣ LIMITS OF SAFE OPERATION AT 25°C PER DIE

PARAMETER	MAX	UNITS
PEAK FORWARD CURRENT*	150	mA
STEADY CURRENT	30	mA
POWER DISSIPATION	105	mW
DERATE FROM 25°C	-1.2	mW/°C
OPERATING, STORAGE TEMP.	-40 TO +85	°C
SOLDERING TEMP.	+260	°C
2.0mm FROM BODY		3 SEC. MAX

* $t < 10\mu\text{s}$

▣ NOTES:

1. SSL-LX2583ID, LED. (5 PCS.)
2. SSH-LXH525, HOLDER.
3. BACKFILL BOTTOM OF HOLDER WITH U.V. GLUE TO SECURE LEDS.

*UNLESS OTHERWISE SPECIFIED TOLERANCES PER DECIMAL PRECISION ARE: X=±1 (±0.039), X.X=±0.5 (±0.020), X.XX=±0.25 (±0.010), X.XXX=±0.127 (±0.005). LEAD SIZE=±0.05 (±0.002), LEAD LENGTH=±0.75 (±0.030). MIN= +DECIMAL PRECISION MAX= +0.00 -DECIMAL PRECISION

UNCONTROLLED DOCUMENT

REV. D	PART NUMBER SSA-LXB525ID
1.8mm x 5.3mm 5 UNIT LED ARRAY, 635nm HIGH INTENSITY RED LEDS, RED DIFFUSED LENS.	

CONFIDENTIAL INFORMATION
THE INFORMATION CONTAINED IN THIS DOCUMENT IS THE PROPERTY OF LUMEX INC. EXCEPT AS SPECIFICALLY AUTHORIZED IN WRITING BY LUMEX INC., THE HOLDER OF THIS DOCUMENT SHALL KEEP ALL INFORMATION CONTAINED HEREIN CONFIDENTIAL AND SHALL PROTECT SAME IN WHOLE OR IN PART FROM DISCLOSURE AND DISSEMINATION TO ALL THIRD PARTIES.

RELIABILITY NOTE
OUR MANY YEARS OF EXPERIENCE DATA ACCUMULATION INDICATE THAT SOLDER HEAT IS A MAJOR CAUSE OF EARLY AND FUTURE FAILURE. PLEASE PAY ATTENTION TO YOUR SOLDERING PROCESS.



290 E. HELEN ROAD
PALATINE, IL 60067-6976
PHONE: +1.847.359.2790
US WEB: www.lumex.com
TW WEB: www.lumex.com.tw

DRAWN BY: CT	CHECKED BY:	APPROVED BY:	DATE: 6.27.90 PAGE: 1 OF 1 SCALE: N/A
-----------------	-------------	--------------	---------------------------------------------