

PART NUMBER	SSL-LX3044UWC	REV.	C
DATE	E.C.N. NUMBER AND REVISION COMMENTS		REV.
04.27.99	E.C.N. #10509.		A
01.06.06	E.C.N. #11283.		B
04.03.12	E.C.N. #11814 & 10BRDR. & REDRAWN.		C

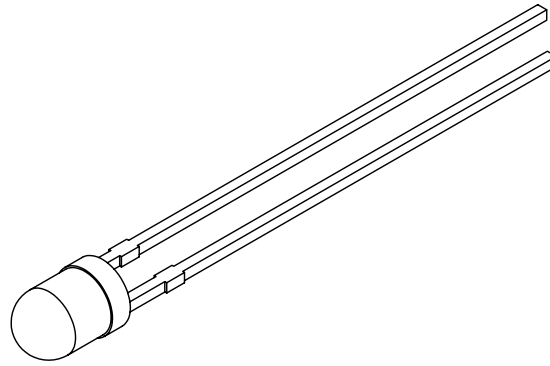
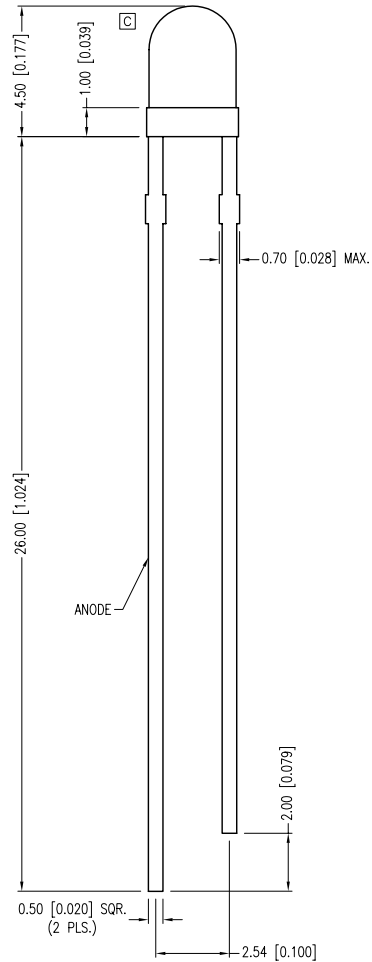
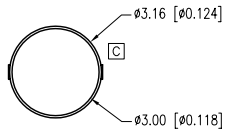

[C] [A] ELECTRO-OPTICAL CHARACTERISTICS $T_a=25^{\circ}\text{C}$ $I_f=20\text{mA}$

PARAMETER	MIN	TYP	MAX	UNITS	TEST COND
PEAK WAVELENGTH		550		nm	
FORWARD VOLTAGE		3.6	4.0	Vf	$I_f=20\text{mA}$
REVERSE VOLTAGE	5.0			Vr	$I_r=10\mu\text{A}$
AXIAL INTENSITY	1400		2000	mcd	$I_f=10\text{mA}$
CHROMATICITY (X)	0.26		0.30		
COORDINATES (Y)**	0.27		0.31		$I_f=20\text{mA}$
VIEWING ANGLE		60		2x theta	
EMITTED COLOR:	WHITE				
LENS FINISH:	WATER CLEAR				

*AXIAL INTENSITY TESTING CONDITION 550nm WAVELENGTH.
 **THE ICI STANDARD COLORIMETRIC SYSTEM.

LIMITS OF SAFE OPERATION AT 25°C

PARAMETER	SYMBOL	MAX	UNITS
PULSE FORWARD CURRENT*	IP	100	mA
STEADY CURRENT	IF	10	mA
POWER DISSIPATION	Id	170	mW
OPERATING TEMP.	TOPR	-40 TO +80	°C
STORAGE TEMP.	SSTG	-40 TO +85	°C
SOLDERING TEMP.		+260	°C
2.0mm FROM BODY		3	SEC. MAX

*DUTY 1/10 PULSE WIDTH 10ms

CAUTION: STATIC SENSITIVE DEVICE
 FOLLOW PROPER E.S.D. HANDLING PROCEDURES
 WHEN WORKING WITH THIS PART.

*UNLESS OTHERWISE SPECIFIED TOLERANCES PER DECIMAL PRECISION ARE: X=±1 (±0.039), X.X=±0.5 (±0.020), X.XX=±0.25 (±0.010), X.XXX=±0.127 (±0.005). LEAD SIZE=±0.05 (±0.002), LEAD LENGTH=±0.75 (±0.030). MIN= ^{+DECIMAL PRECISION} _{-0.00} MAX.= ^{+0.00} _{-DECIMAL PRECISION}

LUMEX
 Creating LED and LCD Solutions Together™

290 E. HELEN ROAD
 PALATINE, IL 60067-6976
 PHONE: +1.847.359.2790
 FAX: +1.847.359.6538
 WEB: WWW.LUMEX.COM
 MEMBER OF ITW PHOTONICS GROUP

T-3mm (T-1) ULTRA WHITE LED, WATER CLEAR LENS.

THE SPECIFICATIONS MAY CHANGE AT ANY TIME WITHOUT NOTICE DUE TO NEW MATERIALS OR PRODUCT IMPROVEMENT.

CONFIDENTIAL INFORMATION
 THE INFORMATION CONTAINED IN THIS DOCUMENT IS THE PROPERTY OF LUMEX INC. EXCEPT AS SPECIFICALLY AUTHORIZED IN WRITING BY LUMEX INC., THE HOLDER OF THIS DOCUMENT SHALL KEEP ALL INFORMATION CONTAINED HEREIN CONFIDENTIAL AND SHALL PROTECT SAME IN WHOLE OR IN PART FROM DISCLOSURE AND DISSEMINATION TO ALL THIRD PARTIES.

DATE:	04.03.12	DRAWN BY:	AB
PAGE:	1 OF 1	CHKD BY:	KF
SCALE:	NTS	APRVD BY:	KF
UNIT:	mm [INCH]		Ⓟ