

CUSTOMER DRAWING

P/N: 7501188-7501468

REV
A

PART NO.	"A" MIN. Ø	SLEEVE COLOR	WIRE SIZE	STUD SIZE
7501188	.142	RED	22-18	#0
7501228	.197	BLUE	16-14	
7501268	.142	RED	22-18	#2
7501308	.197	BLUE	16-14	
7501348	.142	RED	22-18	#4
7501388	.197	BLUE	16-14	
7501428	.142	RED	22-18	#6
7501468	.197	BLUE	16-14	

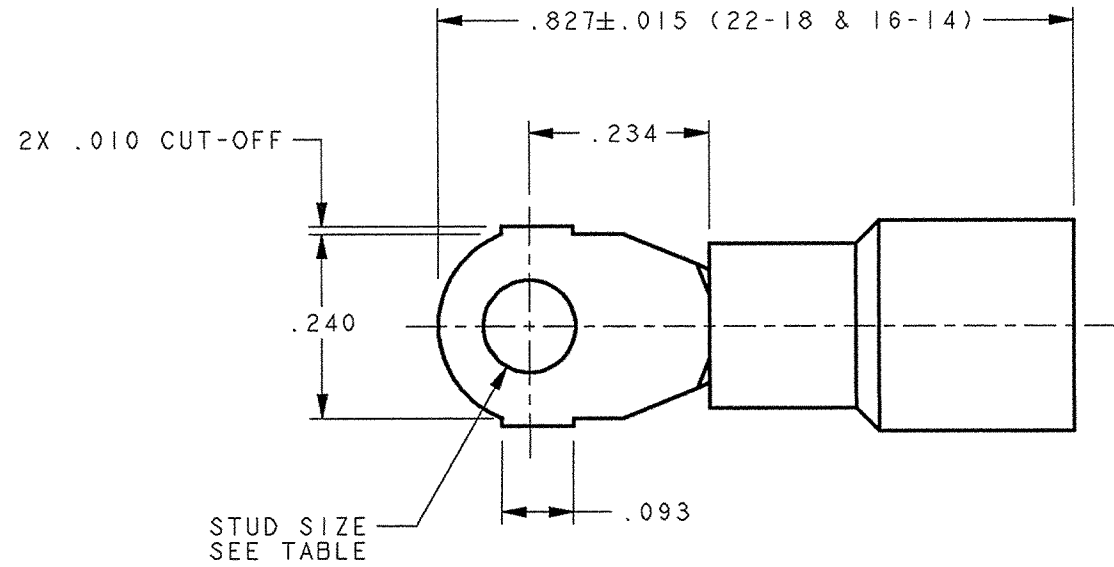

- NOTES:
 1. MATERIAL:
 TERMINAL: .031 THICK COPPER
 PRE-ELECTRO-TIN PLATE: (22-18 & 16-14AWG)
 SLEEVE: 6/6 NYLON
 2. RECOMMENDED STRIP LENGTH: 9/32 ± 1/32 (22-18 & 16-14)
 3. FOR LOOSE PIECE PARTS, ADD SUFFIX 1 TO PART NUMBER (e.g. 75011881)
 4. FOR STANDARD REELING SEE FIGURE 1.

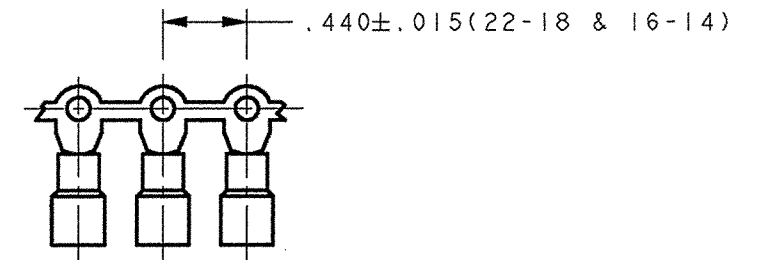
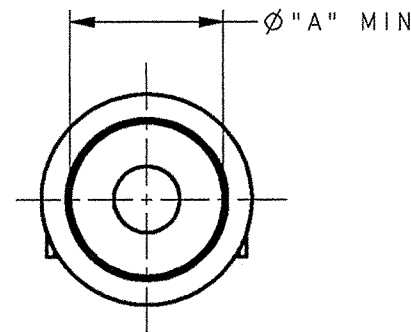
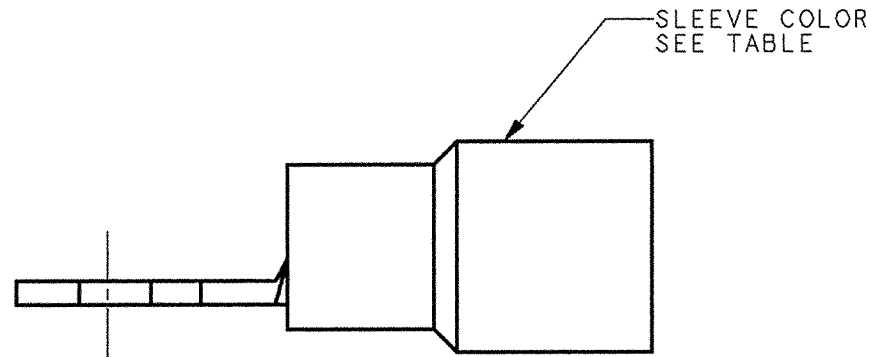

FABRICATED TERMINAL STRIP
SCALE 1X

ARK-LES
UNCONTROLLED

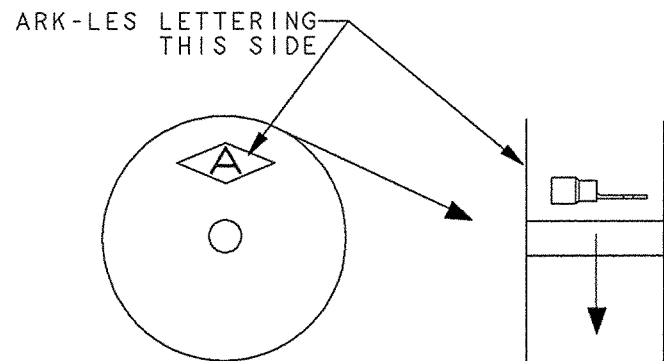

FIGURE 1
REELING DIAGRAM

				PRINT DIST.	PROD. REL. ECR12541	8-1-03	CHK'D	TOLERANCES UNLESS OTHERWISE SPECIFIED	 STOUGHTON, MA
				DEPT #	QUOTE REL.		RWT 6-18-03	DECIMALS ±.010	
				ENG 1	DRAWN BY	BJC 6/10/03	APP.	NETRIC ±0.25mm	ORIGINAL RED
				SALES	SUPERSEDES DWG. DATED:		2/2-03	ANGLES ±1°	PART .240 PRE-INSULATED NAME RING TERMINAL
				STO 8	SCALE 4X	DO NOT SCALE PRINT			CAD#: .240RING-ASSY
A	PROD. REL. PER ECR #12541	6/10/03	BJC	RAL	MATERIAL: SEE NOTE 1				
REV.	DESCRIPTION	DATE	DR.	JZ	FINISH: SEE NOTE 1				
				CHINA					
									 3RD ANGLE PROJECTION
P/N: 7501188-7501468									REV A