

High Precision TCXO / VCTCXO Oscillators

CONNOR WINFIELD

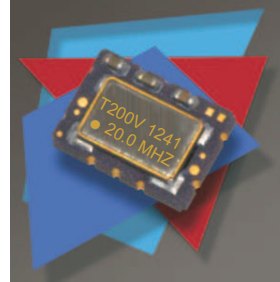

2111 Comprehensive Drive
Aurora, Illinois 60505
Phone: 630-851-4722
Fax: 630-851-5040
www.conwin.com
US Headquarters:
630-851-4722
European Headquarters:
+353-61-472221



Description:

The Connor-Winfield's T100/T200 and the TV100/TV200 series have very high frequency stability with excellent phase noise performance. Available in a 5x7mm surface mount package. These TCXO's and VCTCXO's through the use of Analog Temperature Compensation are capable of holding sub 100-ppb or 200-ppb stabilities over the commercial or industrial temperature ranges. The surface mount package is designed for high-density mounting and is optimum for mass production.

Applications:

Basestation, Communications, DSL / ADSL, Femtocell, IP Timing, LTE, Precision GPS, SONET / SDH, WiMAX / WiBro, WLAN.

Features:

Models:

T100 / T200-Series
TV100 / TV200-Series

Package

T100-T200 Series 5 x 7mm 10 Pad
TV100-TV200 Series 5 x 7mm 4 Pad

Frequencies Available: 10, 12.8, 19.2 or 20 MHz
3.3 Vdc Operation

Output Logic: LVCMOS

Frequency Stability:

T100 / TV100: +/-100 ppb, 0 to 70°C

T200 / TV200: +/-200 ppb, -40 to 85°C

Fixed Frequency - TCXO

Optional Control Voltage - VCTCXO

Low Jitter <0.50 ps RMS

Low Phase Noise

Tri-State Enable/Disable:

Available on T100 / T200 Models.

Tape and Reel Packaging

RoHS Compliant / Lead Free

Ordering Information

T	200	V	- 20.0M
Type / Package TCXO / VCTCXO Series T = 5.0x7.0 mm 10 Pads TV = 5.0x7.0 mm 4 Pads	Frequency Stability and Temperature Range 100 = ±100 ppb, 0 to 70°C 200 = ±200 ppb, -40 to 85°C Supply Voltage = 3.3 Vdc Output Logic = LVCMOS	TCXO or VCTCXO F = TCXO V = VCTCXO	Output Frequency Frequency Format -xxx.xM Min -xxx.xxxxxM Max *Amount of numbers after the decimal point. M = MHz

Example: Part Number

T100F-019.2M = 5x7mm 10 pad package, ±100 ppb, 0 to 70°C, 3.3 Vdc, LVCMOS Output, TCXO, 19.2 MHz
 T200V-020.0M = 5x7mm 10 pad package, ±200 ppb, -40 to 85°C, 3.3 Vdc, LVCMOS Output, VCTCXO, 20.0 MHz
 TV100F-010.0M = 5x7mm 4 pad package, ±100 ppb, 0 to 70°C, 3.3 Vdc, LVCMOS Output, TCXO, 10.0 MHz
 TV200V-012.8M = 5x7mm 4 pad package, ±200 ppb, -40 to 85°C, 3.3 Vdc, LVCMOS Output, VCTCXO, 12.8 MHz



Bulletin **Tx350**
Page **1 of 6**
Revision **04**
Date **09 Jan 2013**

Absolute Maximum Ratings

Parameter	Minimum	Nominal	Maximum	Units	Notes
Storage Temperature	-40	-	85	°C	
Supply Voltage (Vcc)	-0.5	-	4.6	Vdc	
Input Voltage (Vc)	-0.5	-	Vcc + 0.5	Vdc	

Operating Specifications

Parameter	Minimum	Nominal	Maximum	Units	Notes
Output Frequency (Fo)	-	10, 12.8, 19.2 or 20	-	MHz	
Frequency Calibration @ 25 °C	-1.0	-	1.0	ppm	1
Frequency Stability (See Ordering Information for full part number)					
Model T100x, TV100x	-100	-	100	ppb	2
Model T200x, TV200x	-200	-	200	ppb	2
Frequency vs. Load Stability	-0.20	-	0.20	ppm	±5%
Frequency vs. Voltage Stability	-0.20	-	0.20	ppm	±5%
Static Temperature Hysteresis	-	-	0.40	ppm	3
Freq. shift after reflow soldering	-1.0	-	1.0	ppm	4
Long Term Stability	-1.0	-	1.0	ppm	5
Aging					
per Life (20 Years)	-3.0	-	3.0	ppm	
per Day	-40	-	40	ppb	
per Second	-	4.63E-13			
Operating Temperature Range (See Ordering Information for full part number)					
Model T100x, TV100x	0	-	70	°C	
Model T200x, TV200x	-40	-	85	°C	
Supply Voltage (Vcc)	3.135	3.30	3.465	Vdc	
Supply Current (Icc)	-	-	2.1	mA	
Jitter:					
Period Jitter	-	3.0	5.0	ps RMS	
Integrated Phase Jitter (12K to 20M)	-	0.3	1.0	ps RMS	6
SSB Phase Noise for Fo=10.0 MHz					
@ 1 Hz offset	-	-60	-	dBc/Hz	
@ 10 Hz offset	-	-98	-	dBc/Hz	
@ 100 Hz offset	-	-126	-	dBc/Hz	
@ 1 KHz offset	-	-143	-	dBc/Hz	
@ 10 KHz offset	-	-151	-	dBc/Hz	
@ 100 KHz offset	-	-152	-	dBc/Hz	
@ 1 MHz offset	-	-155	-	dBc/Hz	
Start-Up Time		-	-	10	ms



Control Voltage Input Characteristics

Parameter	Minimum	Nominal	Maximum	Units	Notes
Control Voltage	0.3	1.65	3.0	V	
Frequency Pullability	±10	-	-	ppm	
Control Voltage Slope		Positive Slope			
Monotonic Linearity	-	-	10	%	
Input Impedance	100K	-	-	Ohm	
Modulation Bandwidth (3dB)	10	-	-	KHz	

Enable /Disable Input Characteristics (Pad 8) (Models T100F, T200F, T100V and T200V Only)

Parameter	Minimum	Nominal	Maximum	Units	Notes
Enable Input Voltage -(Vih)	70%Vcc	-	-	Vdc	7
Disable Input Voltage - (Vil)	-	-	30%Vcc	Vdc	7

Function	Output
Low:	Disabled (High Impedance)
High or Open:	Enabled

LVC MOS Output Characteristics

Parameter	Minimum	Nominal	Maximum	Units	Notes
Load (CL)	-	15	-	pF	8
Voltage (High) (Voh)	90%Vcc	-	-	Vdc	
(Low) (Vol)	-	-	10%Vcc	Vdc	
Duty Cycle at 50% of Vcc	45	50	55	%	
Rise / Fall Time 10% to 90%	-	4	8	ns	

Package Characteristics

Package	Hermetically sealed ceramic package with grounded metal cover
---------	---

Environmental Characteristics

Vibration:	Vibration per Mil Std 883E Method 2007.3 Test Condition A.
Shock:	Mechanical Shock per Mil Std 883E Method 2002.4 Test Condition B.
Soldering Process:	RoHS compliant lead free. See soldering profile on page 2.

Notes:

1. Initial calibration @ 25°C. ±2°C, for VCTCXO's Vc = 1.65V. Specifications at time of shipment after 48 hours of operation.
2. Frequency stability vs. change in temperature. $[\pm(F_{max}-F_{min})/2.F_0]$. For VCTCXO's - Vc = 1.65V
3. Frequency change after reciprocal temperature ramped over the operating range. Frequency measured before and after at 25°C
4. Two consecutive reflows after 1 hour recovery @ 25°C.
5. Frequency drift over 1 year @ 25°C.
6. BW = 12 KHz to 20 MHz
7. Leave Pad 8 on models, T100F, T200F, T100V, T200V unconnected if enable / disable function is not required. When tri-stated, the output stage is disabled but the oscillator and compensation circuit are still active (current consumption < 1 mA).
8. Attention: To achieve optimal frequency stability, and in some cases to meet the specification stated on this data sheet, it is required that the circuit connected to this TCXO output must have the equivalent input capacitance that is specified by the nominal load capacitance. Deviations from the nominal load capacitance will have a graduated effect on the stability of approximately 20 ppb per pF load difference..

Bulletin	Tx350
Page	3 of 6
Revision	04
Date	09 Jan 2013



T100/T200 Package Outline

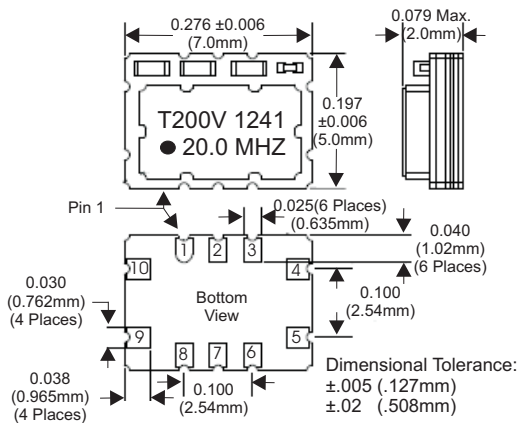

T100/T200 Suggested Pad Layout

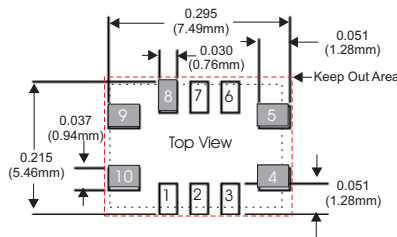

* Do not route any traces in the keep out area. It is recommended the next layer under the keep out area is to be ground plane.

T100/T200 Pad Connections

- 1: Do Not Connect
- 2: Do Not Connect
- 3: Do Not Connect
- 4: Ground
- 5: Output
- 6: Do Not Connect
- 7: Do Not Connect
- 8: Enable / Disable
- 9: Supply Voltage (Vcc)
- 10: VCTCXO: Control Voltage (Vc)
TCXO: N/C

TV100/TV200 Package Outline

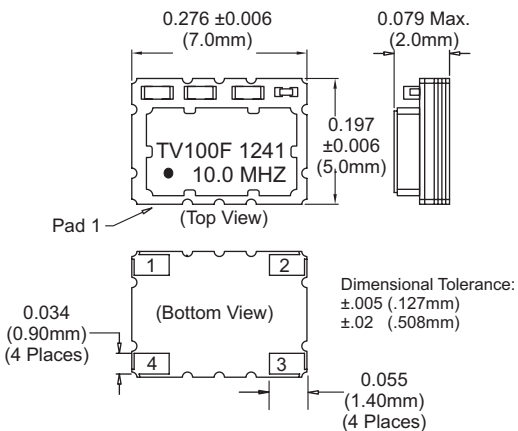

TV100/TV200 Suggested Pad Layout

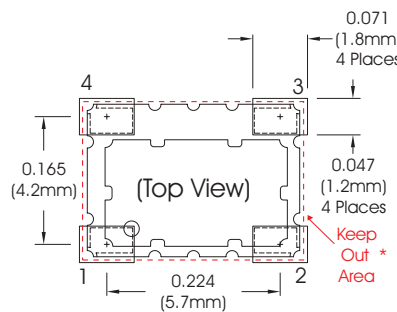

* Do not route any traces in the keep out area. It is recommended the next layer under the keep out area is to be ground plane.

TV100/TV200 Pad Connections

- 1: VCTCXO: Voltage Control (Vc)
TCXO: N/C
- 2: Ground
- 3: Output
- 4: Supply (Vcc)

T100 / T200 Design Recommendations

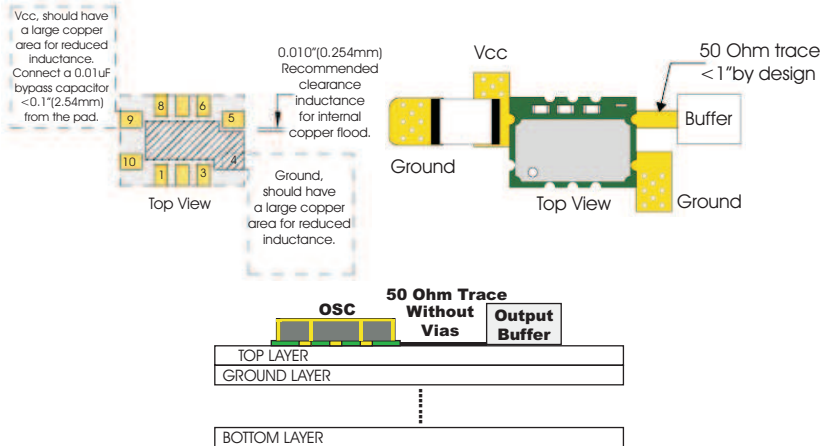

T100 / T200 Test Circuit

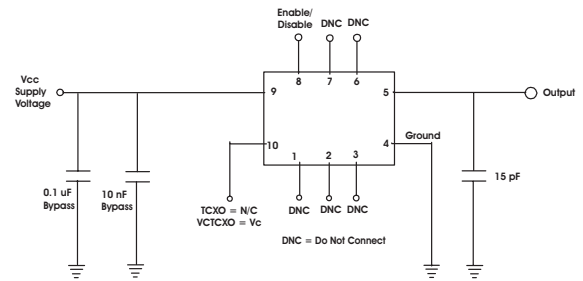

TV100 / TV200 Design Recommendations

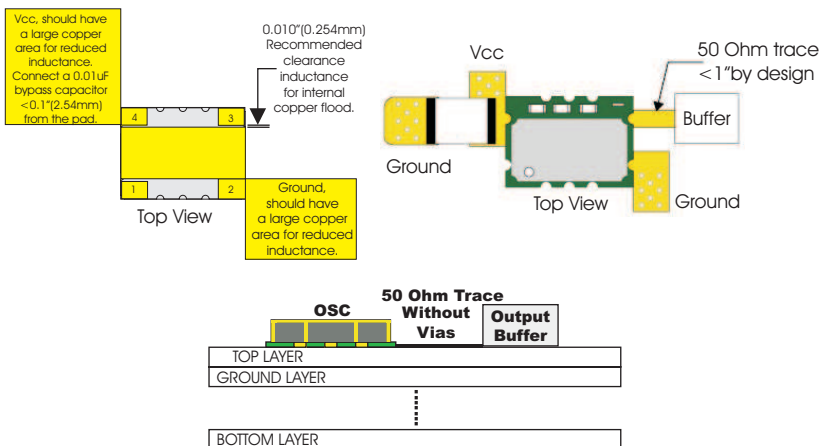

TV100 / TV200 Test Circuit

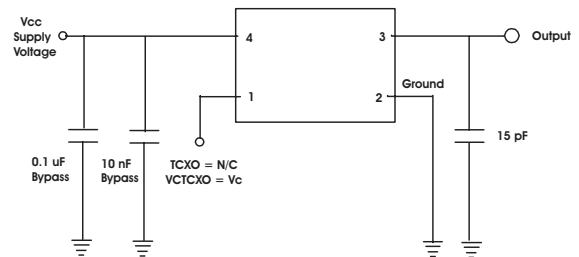

Attention: To achieve optimal frequency stability, and in some cases to meet the specification stated on this data sheet, it is required that the circuit connected to this TCXO output must have the equivalent input capacitance that is specified by the nominal load capacitance. Deviations from the nominal load capacitance will have a graduated effect on the stability of approximately 20 ppb per pF load difference.

LVCMOS Output Waveform

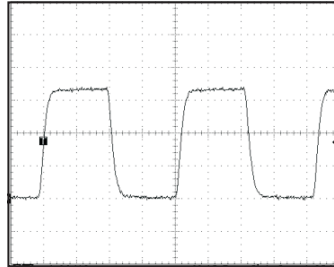

Phase Noise Information

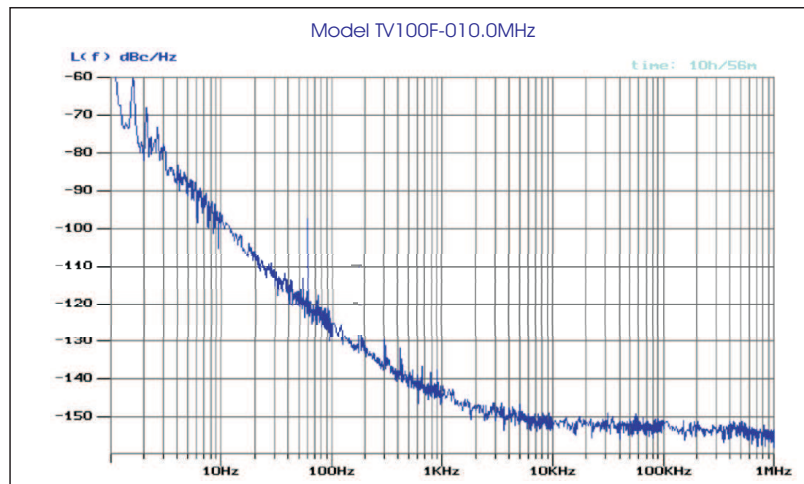

5x7 mm Tape and Reel Information

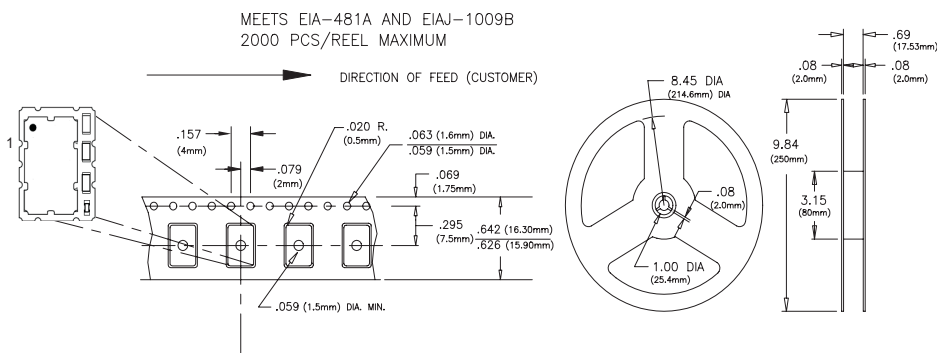

Solder Profile

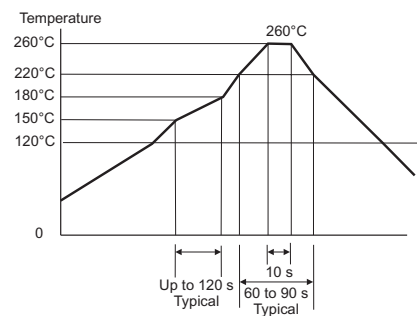

Meets IPC/JEDEC J-STDP-020C

Revision History

Revision A00	Advanced information data sheet released 12/05/11
Revision A01	Added 12.8 MHz and +/-50ppb 0 to 70 °C Models 04/24/12
Revision A02	Updated integrated phase jitter to 0.3 ps RMS nominal. 04/26/12
Revision 03	Removed M series 10/12/12
Revision 04	Updated phase noise information 01/09/13

Bulletin	Tx350
Page	6 of 6
Revision	04
Date	09 Jan 2013