

Improved Performance 5x7mm TCXO / VCTCXO



2111 Comprehensive Drive
Aurora, Illinois 60505
Phone: 630-851-4722
Fax: 630-851-5040
www.conwin.com
US Headquarters:
630-851-4722
European Headquarters:
+353-61-472221

Description:

Connor-Winfield's TBxxx and TVBxxx series are 5x7mm TCXO and VCTCXO products with exceptional frequency stability and low phase noise. Through the use of analog temperature compensation, these products are capable of holding Stratum 3 level temperature stabilities of ± 0.28 ppm over the commercial and industrial temperature ranges. Available in 4-pad or 10-pad surface mount footprints.

These products are designed for such applications as IEEE 1588 PTP or Synchronous Ethernet.

Using the latest analog TCXO technology, the TBxxx and TVBxxx series have improved phase noise and frequency stability performance.

Applications:

- IEEE 1588 Applications
- Synchronous Ethernet slave clocks, ITU-T G.8262 EEC options 1 & 2
- Compliant to Stratum 3, GR-1244-CORE & GR-253-CORE
- Wireless Communications
- Small Cells
- Test and Measurement

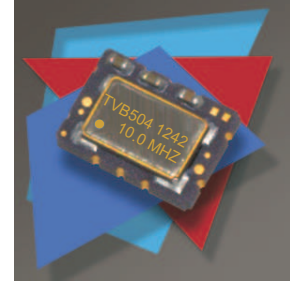

Features:

- Frequency Stabilities Available:
 ± 0.28 ppm (10 to 54 MHz)
 ± 0.50 ppm, ± 1.00 ppm or ± 2.00 ppm (10 to 100 MHz)
- Temperature Ranges Available:
 0 to 85°C, 0 to 70°C, -40 to 85°C or -20 to 70°C
- Packages Available:
 TB - Series: 5 x 7mm - 10 Pad
 TVB - Series: 5 x 7mm - 4 Pad
- 3.3 Vdc Operation
 Output Logic: LVCMOS or Clipped Sinewave
 Fixed Frequency - TCXO
 Voltage Controlled - VCTCXO
 Low Jitter <math>< 0.50 \text{ ps RMS}</math>
 Low Phase Noise
 Tri-State Enable/Disable: (TB - Model Series Only)
 Tape and Reel Packaging
 RoHS Compliant / Lead Free

Standard Frequencies Available *

* 10.0 MHz, 12.8 MHz, 19.2 MHz, 19.44 MHz, 20.0 MHz, 25.0 MHz, 38.88 MHz, 40 MHz and 50 MHz
 Available frequencies from the factory for small quantity orders or quick delivery.
 Additional frequencies are available.

Ordering Information

TVB	5	0	4	- 010.0M
Type / Package TCXO / VCTCXO Series TB = 5.0x7.0 mm 10 Pads TVB = 5.0x7.0 mm 4 Pads	Temperature Range 3 = 0 to 85 °C 5 = 0 to 70°C 6 = -40 to 85°C 7 = -20 to 70°C	Frequency Stability 0 = ± 0.28 ppm 1 = ± 0.50 ppm 2 = ± 1.00 ppm 3 = ± 2.00 ppm	Features 2 = TCXO, LVCMOS, 3.3 Vdc 3 = TCXO, Clipped Sinewave, 3.3 Vdc 4 = VCTCXO, LVCMOS, 3.3 Vdc 5 = VCTCXO, Clipped Sinewave, 3.3 Vdc	Output Frequency Frequency Format -xxx.xM Min -xxx.xxxxxxM Max *Amount of numbers after the decimal point. M = MHz

Example: Part Number

TVB504-010.0M = 5x7mm 4 pad package, ± 0.28 ppm, 0 to 70°C, 3.3 Vdc, LVCMOS Output, VCTCXO
 TB715-012.8M = 5x7mm 10 pad package, ± 0.50 ppm, -20 to 70°C, 3.3 Vdc, Clipped Sinewave Output, VCTCXO
 TB622-050.0M = 5x7mm 10 pad package, ± 1.0 ppm, -40 to 85°C, 3.3 Vdc, LVCMOS Output, TCXO
 TVB602-010.0M = 5x7mm 4 pad package, ± 0.28 ppm, -40 to 85°C, 3.3 Vdc, LVCMOS Output, TCXO



Bulletin **Tx380**
 Page **1 of 6**
 Revision **02**
 Date **25 Feb 2013**

Absolute Maximum Ratings

Parameter	Minimum	Nominal	Maximum	Units	Notes
Storage Temperature	-55	-	125	°C	
Supply Voltage (Vcc)	-0.5	-	6.0	Vdc	
Input Voltage (Vc)	-0.5	-	Vcc + 0.5	Vdc	

Operating Specifications

Parameter	Minimum	Nominal	Maximum	Units	Notes
Output Frequency (Fo)					
Models TBx0x, TVBx0x	10	-	50	MHz	
Models TBx1x, TVBx1x	10	-	100	MHz	
Models TBx2x, TVBx2x	10	-	100	MHz	
Models TBx3x, TVBx3x	10	-	100	MHz	
Operating Temperature Range	(See Ordering Information for full part number)				
Models TB3xx, TVB3xx	0	-	85	°C	
Models TB5xx, TVB5xx	0	-	70	°C	
Models TB6xx, TVB6xx	-40	-	85	°C	
Models TB7xx, TVB7xx	-20	-	70	°C	
Frequency Calibration @ 25 °C	-1.0	-	1.0	ppm	1
Frequency Stability (See Ordering Information for full part number)	Per STRATUM 3 GR-1244-CORE				
Models TBx0x, TVBx0x	-0.28	-	0.28	ppm	2
Holdover Stability	-0.32	-	0.32	ppm	3
Frequency Stability	(See Ordering Information for full part number)				
Models TBx1x, TVBx1x	-0.50	-	0.50	ppm	2
Models TBx2x, TVBx2x	-1.00	-	1.00	ppm	2
Models TBx3x, TVBx3x	-2.00	-	2.00	ppm	2
Frequency vs. Load Stability	-0.20	-	0.20	ppm	±5%
Frequency vs. Voltage Stability	-0.20	-	0.20	ppm	±5%
Static Temperature Hysteresis	-	-	0.40	ppm	4
Freq. shift after reflow soldering	-1.0	-	1.0	ppm	5
Long Term Stability	-1.0	-	1.0	ppm	6
Aging					
per Life (20 Years)	-3.0	-	3.0	ppm	
per Day	-40	-	40	ppb	
per Second	-	4.63E-13	-		
Supply Voltage (Vcc)	3.135	3.30	3.465	Vdc	
Supply Current (Icc)					
LVCMOS	-	2.1	6.0	mA	
Clipped Sinewave	-	1.3	2.9	mA	
Jitter:					
Period Jitter	-	3.0	5.0	ps RMS	
Integrated Phase Jitter (12K to Fo/2)	-	0.5	1.0	ps RMS	7
Typical SSB Phase Noise					
For Fo	10.0 MHz	50.0 MHz	100.0 MHz		
@ 10 Hz offset	-98	-70	-60	dBc/Hz	
@ 100 Hz offset	-125	-100	-91	dBc/Hz	
@ 1 KHz offset	-143	-122	-119	dBc/Hz	
@ 10 KHz offset	-151	-145	-142	dBc/Hz	
@ 100 KHz offset	-152	-150	-153	dBc/Hz	
@ 1 MHz offset	-155	-152	-153	dBc/Hz	
Start-Up Time	-	-	-	10	ms



Control Voltage Input Characteristics

Parameter	Minimum	Nominal	Maximum	Units	Notes
Control Voltage	0.3	1.65	3.0	V	
Frequency Pullability	±10	-	-	ppm	
Control Voltage Slope		Positive Slope			
Monotonic Linearity	-	-	10	%	
Input Impedance	100K	-	-	Ohm	
Modulation Bandwidth (3dB)	10	-	-	KHz	

Enable /Disable Input Characteristics (Pad 8)

TB Series only

Parameter	Minimum	Nominal	Maximum	Units	Notes
Enable Input Voltage -(Vih)	70%Vcc	-	-	Vdc	8
Disable Input Voltage - (Vil)	-	-	30%Vcc	Vdc	8

Function	Output
Low:	Disabled (High Impedance)
High or Open:	Enabled

LVC MOS Output Characteristics

Parameter	Minimum	Nominal	Maximum	Units	Notes
Load (CL)	-	15	-	pF	9
Voltage (High) (Voh)	90%Vcc	-	-	Vdc	
Voltage (Low) (Vol)	-	-	10%Vcc	Vdc	
Duty Cycle at 50% of Vcc	45	50	55	%	
Rise / Fall Time 10% to 90%	-	4	8	ns	

Clipped Sinewave Output Characteristics

Parameter	Minimum	Nominal	Maximum	Units	Notes
Load (CL)					
Output Load Resistance	-	10K	-	Ohm	
Output Load Capacitance	-	10	-	pF	
Output Voltage(≤ 40 MHz)	1.0	1.2	-	V	pk-pk
Output Voltage(>40 MHz)	0.8	1.0	-	V	pk-pk

Package Characteristics

Package	Hermetically sealed ceramic package with grounded metal cover
---------	---

Environmental Characteristics

Vibration:	Vibration per Mil Std 883E Method 2007.3 Test Condition A.
Shock:	Mechanical Shock per Mil Std 883E Method 2002.4 Test Condition B.
Soldering Process:	RoHS compliant lead free. See soldering profile on page 2.

Notes:

1. Initial calibration @ 25°C. ±2°C, for VCTCXO's Vc = 1.65V. Specifications at time of shipment after 48 hours of operation.
2. Frequency stability vs. change in temperature. $[\pm(F_{max}-F_{min})/(2*F_0)]$. For VCTCXO's - Vc = 1.65V
3. Inclusive of frequency stability, supply voltage change (±1%), aging, for 24 hours. Per STRATUM 3 GR-1244-CORE.
4. Frequency change after reciprocal temperature ramped over the operating range. Frequency measured before and after at 25°C
5. Two consecutive solder reflows after 1 hour recovery @ 25°C.
6. Frequency drift over 1 year @ 25°C.
7. BW = 12 KHz to 20 MHz
8. Leave Pad 8 on the TB Series unconnected if enable / disable function is not required. When tri-stated, the output stage is disabled but the oscillator and compensation circuit are still active (current consumption < 1 mA).
9. Attention: To achieve optimal frequency stability, and in some cases to meet the specification stated on this data sheet, it is required that the circuit connected to this TCXO output must have the equivalent input capacitance that is specified by the nominal load capacitance. Deviations from the nominal load capacitance will have a graduated effect on the stability of approximately 20 ppb per pF load difference..

Bulletin	Tx380
Page	3 of 6
Revision	02
Date	25 Feb 2012



TB Series Package Outline

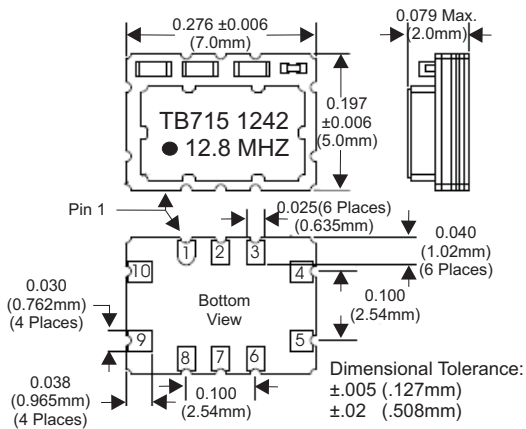

TB Series Suggested Pad Layout

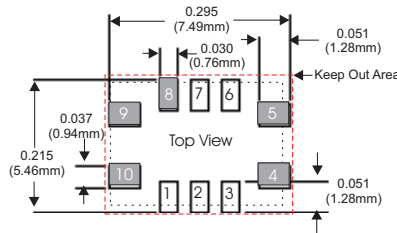

* Do not route any traces in the keep out area. It is recommended the next layer under the keep out area is to be ground plane.

TB Series Pad Connections

- 1: Do Not Connect
- 2: Do Not Connect
- 3: Do Not Connect
- 4: Ground
- 5: Output
- 6: Do Not Connect
- 7: Do Not Connect
- 8: Enable / Disable
- 9: Supply Voltage (Vcc)
- 10: VCTCXO: Control Voltage (Vc)
TCXO: N/C

TVB Series Package Outline

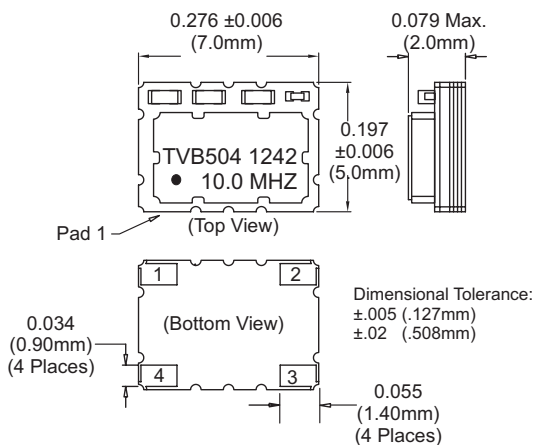

TVB Series Suggested Pad Layout

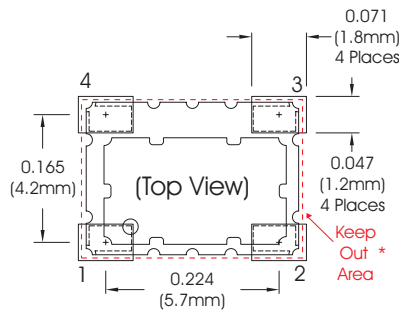

* Do not route any traces in the keep out area. It is recommended the next layer under the keep out area is to be ground plane.

TVB Series Pad Connections

- 1: VCTCXO: Voltage Control (Vc)
TCXO: N/C
- 2: Ground
- 3: Output
- 4: Supply (Vcc)

TB Series Design Recommendations

TVB Series Design Recommendations

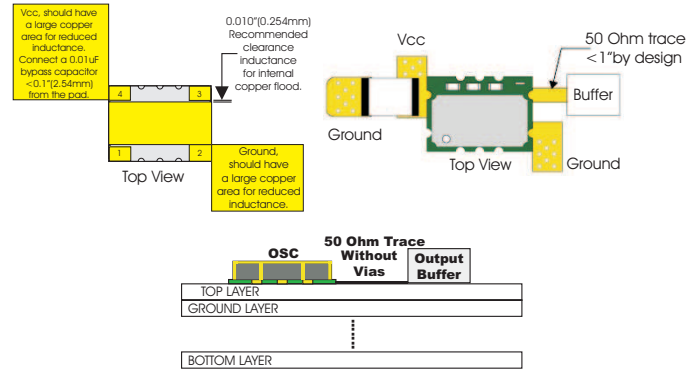
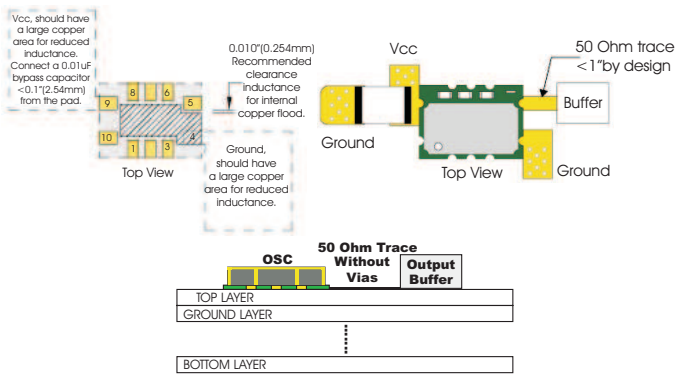

TB Series LVC MOS Test Circuit

TVB Series LVC MOS Test Circuit

LVC MOS Output Waveform

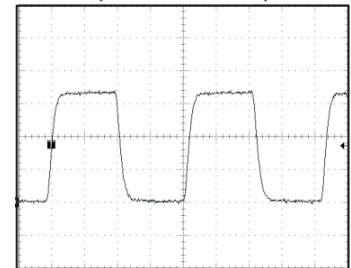
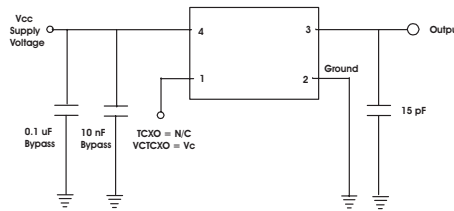
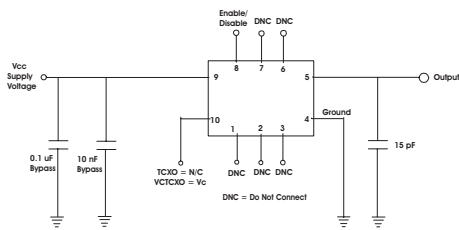

TB Series Clipped Sinewave Test Circuit

TVB Series Clipped Sinewave Test Circuit

Clipped Sinewave Output Waveform

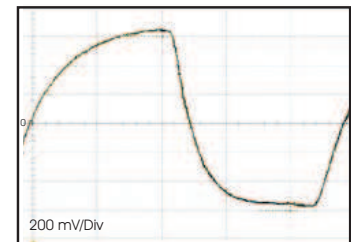
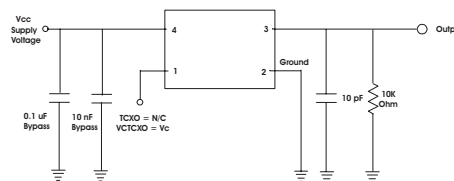
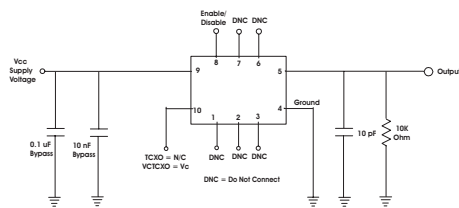

Phase Noise Information

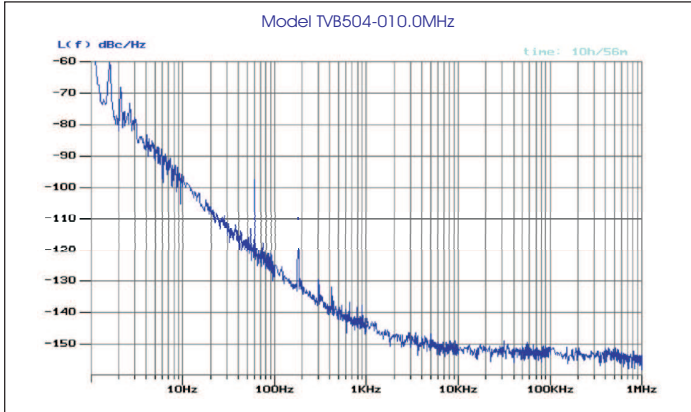

TIE

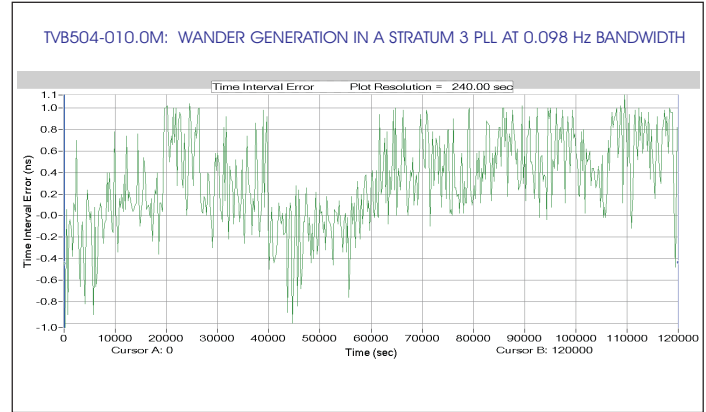

MTIE

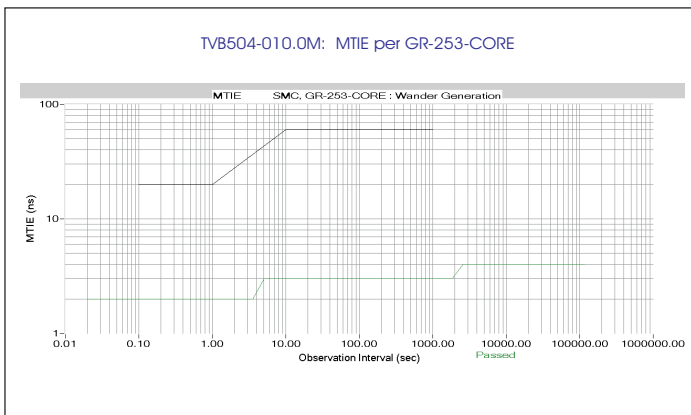

TDEV

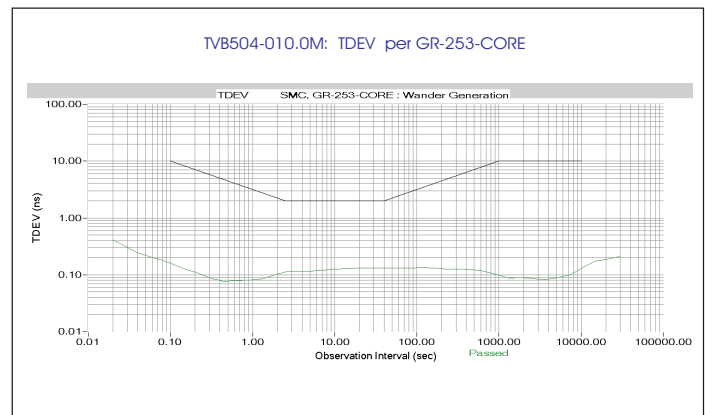

5x7mm Tape and Reel Information

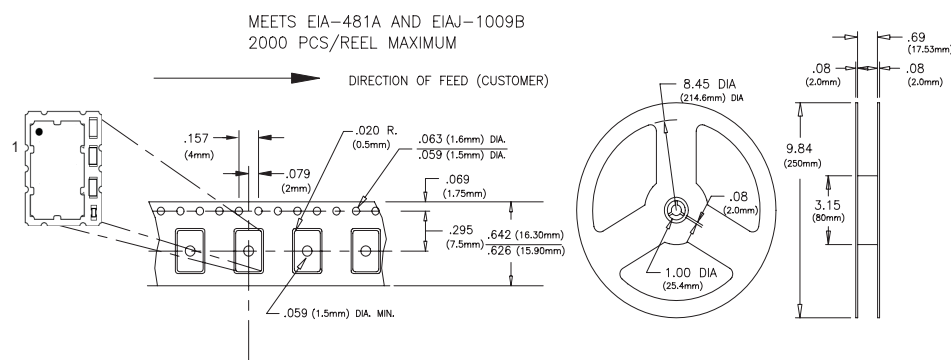

Solder Profile

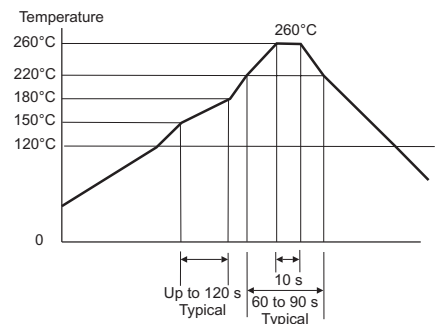

Meets IPC/JEDEC J-STD-020C

Revision History

Revision 00	Data sheet released 10/23/12
Revision 01	Added Digi-Key 11/29/12.
Revision 02	Increased frequency range to 100 MHz 02/25/13

Bulletin	Tx380
Page	6 of 6
Revision	02
Date	25 Feb 2013