

CRYSTAL CONTROLLED OSCILLATORS

3.3V 5 x 7mm SURFACE MOUNT HIGH FREQUENCY LVPECL VCXO OSCILLATOR

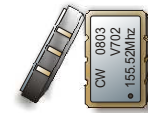

V702

ABSOLUTE MAXIMUM RATINGS

TABLE 1.0

PARAMETER	UNITS	MINIMUM	NOMINAL	MAXIMUM	UNITS	NOTE
Storage Temperature		-55	-	125	°C	
Supply Voltage	(Vcc)	-0.5	-	4.6	Vdc	
Control Voltage	(Vc)	-0.5	-	Vcc+0.5	Vdc	

OPERATING SPECIFICATIONS

TABLE 2.0

PARAMETER		MINIMUM	NOMINAL	MAXIMUM	UNITS	NOTE
Center Frequency	(Fo)	20	-	200	MHz	
Operating Temperature Range		0	-	70	°C	
Supply Voltage	(Vcc)	3.135	3.3	3.465	Vdc	
Supply Current	(Icc)	-	-	100	mA	
Period Jitter RMS		-	3	5	ps rms	
Integrated Phase Jitter (BW=12kHz to 20MHz)		-	0.3	1.0	ps rms	
Typical Phase Noise for 155.52MHz						
SSB Phase Noise at 10Hz offset		-	-60	-	dBc/Hz	
SSB Phase Noise at 100Hz offset		-	-90	-	dBc/Hz	
SSB Phase Noise at 1KHz offset		-	-120	-	dBc/Hz	
SSB Phase Noise at 10KHz offset		-	-140	-	dBc/Hz	
SSB Phase Noise at 100KHz offset		-	-145	-	dBc/Hz	

INPUT CHARACTERISTICS

TABLE 3.0

PARAMETER		MINIMUM	NOMINAL	MAXIMUM	UNITS	NOTE
Control Voltage Range	(Vc)	0.3	1.65	3.0	Vdc	
Typical Slope (Fo = 155.52MHz)		-	75	-	ppm/V	
Absolute Pull Range (APR)		±50	-	-	ppm	1
Monotonic Linearity		-10	-	10	%	
DC Input Resistance (Pad 1)		-	60K	-	Ohm	
Modulation Bandwidth (3dB)		25	-	-	KHz	
Enable Input Voltage (Low)	(Vil)	-	-	1.68	Vdc	2
Disable Input Voltage (High)	(Vih)	2.275	-	-	Vdc	2

LVPECL OUTPUT CHARACTERISTICS

TABLE 4.0

PARAMETER		MINIMUM	NOMINAL	MAXIMUM	UNITS	NOTE
LOAD		-	-	50	Ohms	3
Voltage (High)	(Voh)	2.275	-	-	Vdc	
(Low)	(Vol)	-	-	1.68	Vdc	
Duty Cycle at 50% Level		45	50	55	%	
Rise / Fall Time 20% to 80%		-	0.6	1.5	ns	

PACKAGE CHARACTERISTICS

TABLE 5.0

Package	Hermetically sealed ceramic package with grounded metal cover
Soldering Process	RoHS compliant / lead free, see solder profile on page 2.

ORDERING INFORMATION

V 7	0	2	-	155.52M
Type: LVPECL VCXO 5.0x7.0mm Package	Temperature Range: 0 = 0 to 70° C.	APR and Supply Voltage: 2 = ± 50 ppm 3.3 Vdc		Output Frequency: Frequency Format -xxx.xM Minimum* -xxx.xxxxxM Maximum* *Amount of numbers after the decimal point. M = MHz

DESCRIPTION

The Connor-Winfield V702 is a 3.3V Voltage Controlled Crystal Oscillator (VCXO) with LVPECL Differential outputs and enable/disable function. The V702 is designed for use with applications utilizing a PLL system requiring low jitter and tight frequency stability. No multiplication schemes are used in this oscillator design. The surface mount package is designed for high-density mounting and is optimum for mass production.

FEATURES

20 to 200 MHz

3.3V OPERATION

LOW JITTER <1ps RMS

ABSOLUTE PULL RANGE (APR): ±50ppm

TEMPERATURE RANGE: 0 to 70°C

DIFFERENTIAL LVPECL OUTPUTS

ENABLE / DISABLE FUNCTION

SURFACE MOUNT PACKAGE

TAPE AND REEL PACKAGING

RoHS COMPLIANT / LEAD FREE

Example: To order an V702 with an output frequency of:
25 MHz = V702-025.0M
44.736 MHz = V702-044.736M
155.52 MHz = V702-155.52M

Specifications subject to change without notice.



CRYSTAL CONTROLLED OSCILLATORS

Notes

- 1.0 Absolute pull range (APR) is the minimum guaranteed pull range of the VCXO under all conditions over the lifetime operation. Including calibration @ 25°C, frequency vs. change in temperature, frequency vs. change in supply voltage, frequency vs. change in load, shock and vibration and aging for ten years. The APR is referenced to Fo. Positive Transfer Function.
- 2.0 Outputs are enabled with no connection on pad 2. When oscillator is disabled both outputs are in a high impedance state.
- 3.0 50 ohm termination into Vcc-2V or Thevein equivalent.

Pad Connections

TABLE 6.0	
Pad	Pad Connection
1	Control Voltage
2	Enable / Disable
3	Ground (Case)
4	Output Q
5	Output Q
6	Vcc

Enable / Disable Function

Output Enable Function		TABLE 7.0
Enable / Disable Function (Pad 2)	Output	
No Connection	Enable	
Low	Enable	
High	Disable (High Impedance)	

Package Outline

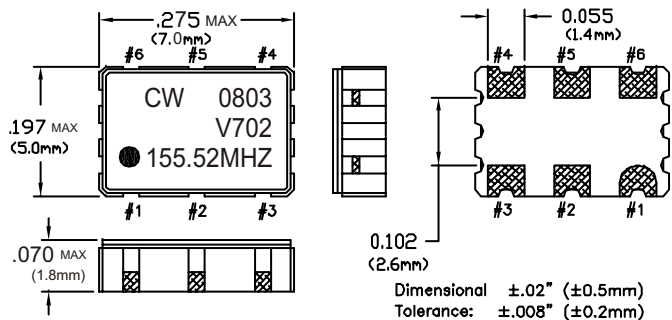

Output Waveform

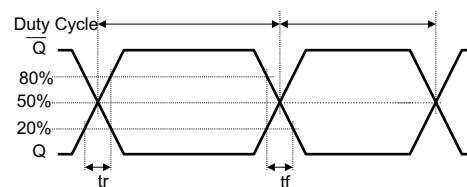

Suggested Pad Layout

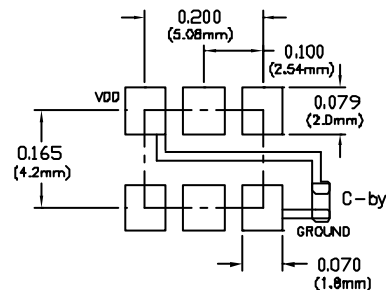

Bypass capacitor, C-by, should be ceramic capacitor $\geq .01\mu\text{f}$.

Test Circuit

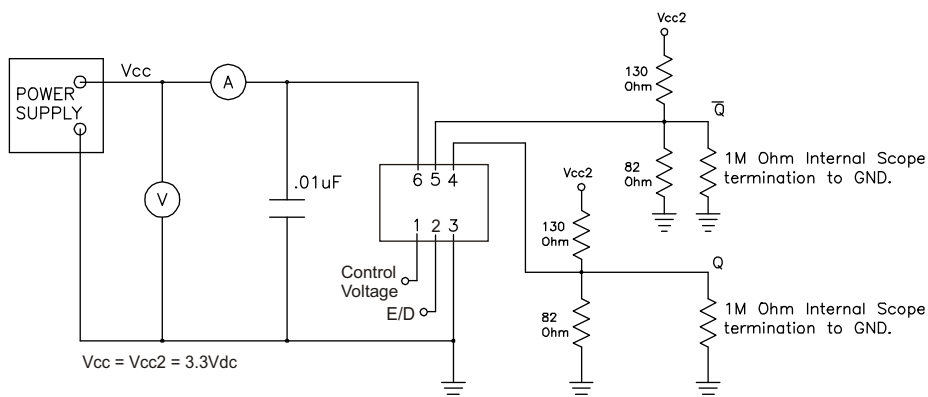

Solder Profile

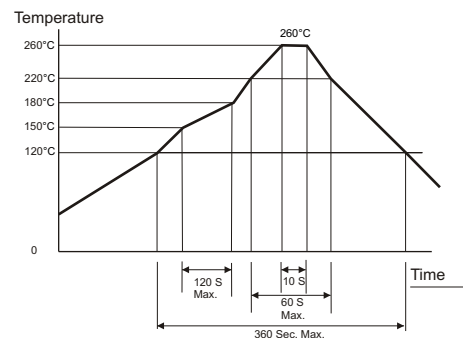

Specifications subject to change without notice.