

MSTM-S3-TR Stratum 3 Timing Module



2111 Comprehensive Drive
Aurora, Illinois 60505
Phone: 630-851-4722
Fax: 630-851-5040
www.conwin.com



Application

The Connor-Winfield MSTM-S3-TR Simplified Control Timing Module acts as a complete system clock module for Stratum 3 timing applications in accordance with GR-1244, Issue 2 and GR-253, Issue 3.

Connor Winfield's Stratum 3 timing modules helps reduce the cost of your design by minimizing your development time and maximizing your control of the system clock with our simplified design.

Features

- 5V Miniature Timing Module
- Redundant References
- 2 Synchronous Outputs Available From 8 kHz to 77.76MHz
- 40 sec., Filtered, Hold Over History
- Operational Status Flags

Bulletin	TM027
Page	1 of 16
Revision	P05
Date	02 DEC 02
Issued By	MBatts

General Description

The Connor-Winfield Stratum 3 Simplified Control Timing Module acts as a complete system clock module for general Stratum 3 timing applications. The MSTM is designed to replace similar units from TF Systems (TF118B) and Raltron (SY0001B).

Full external control input allows for selection and monitoring of any of four possible operating states: 1) Holdover, 2) External Reference #1, 3) External Reference #2, and 4) Free Run. Table #1 illustrates the control signal inputs and corresponding operational states.

In the absence of External Control Inputs (A,B), the MSTM enters the Free Run mode and signals an External Alarm. The MSTM will enter other operating modes upon application of a proper control signal. Mode 1 operation (A=1, B=0) results in an output signal that is phase locked to the External Reference Input #1. Mode 2 operation (A=0, B=1) results in an output signal that is phase locked to External Reference Input #2. Hold-over mode operation (A=1, B=1) results in an output signal at or near the frequency as determined by the latest (last) locked-signal input values and the holdover performance of the MSTM. Free Run Mode/Free Run mode operation (A=0, B=0) is a guaranteed output of 4.6 ppm of the nominal frequency.

Alarm signals are generated at the Alarm Output during Hold-over and Free Run operation. Alarm Signals are also generated by Loss-of-Lock and Loss-of-Reference conditions. A high level indicates an alarm condition. Real-time indication of the operational mode is available at unique operating mode outputs on pins 1-4.

Control loop 0.1 Hz filters effectively attenuate any reference jitter, smooth out phase transients, comply with wander transfer and jitter tolerances.

Functional Block Diagram

Figure 1

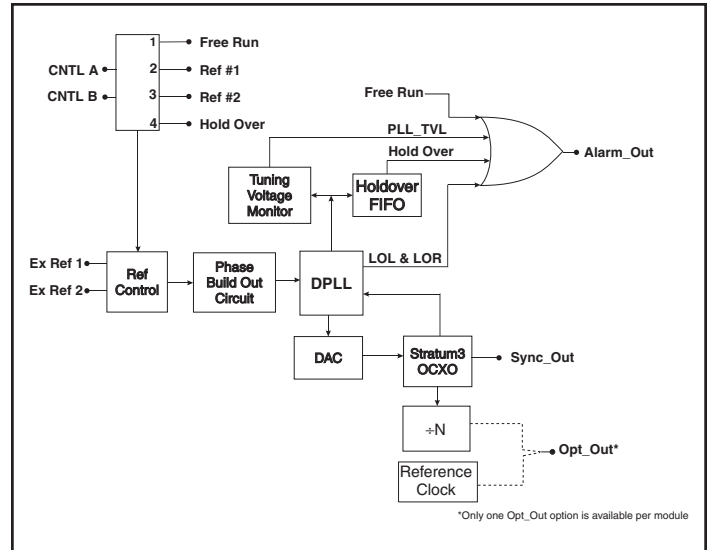

Function Control Table

Table 1

CNTL A	CNTL B	Operational Mode	Ref 1	Ref 2	Hold Over	Free Run	PLL Unlock	Alarm Out
0	0	Free Run (Default Mode)	0	0	0	1	0	1
1	0	External Reference #1						
		Normal	1	0	0	0	0	0
		PLL_Unlock	1	0	0	0	1	0
		LOR	0	0	1	0	0	1
0	1	External Reference #2						
		Normal	0	1	0	0	0	0
		PLL_Unlock	0	1	0	0	1	0
		LOR	0	0	1	0	0	1
1	1	Hold Over	0	0	1	0	0	1

Absolute Maximum Rating

Table 2

Symbol	Parameter	Minimum	Nominal	Maximum	Units	Notes
V _{CC}	Power Supply Voltage	-0.5		7.0	Volts	1.0
V _I	Input Voltage	-0.5		V _{CC} + 0.5	Volts	1.0
T _s	Storage Temperature	-55		100	deg. C	1.0

Recommended Operating Conditions

Table 3

Symbol	Parameter	Minimum	Nominal	Maximum	Units	Notes
V _{CC}	Power supply voltage	4.75	5.00	5.25	Volts	
V _{TH}	Reset threshold voltage	4.25		4.5	Volts	
V _{IH}	High level input voltage - TTL	2.0		V _{CC}	Volts	
V _{IL}	Low level input voltage - TTL	0		0.8	Volts	
t _{IN}	Input signal transition - TTL			250	ns	
C _{IN}	Input capacitance			15	pF	
V _{OH}	High level output voltage, I _{OH} = -4.0mA, V _{CC} = min.	2.4		5.25	Volts	2.0
V _{OL}	Low level output voltage, I _{OL} = 12.0 mA, V _{CC} = min.			0.4	Volts	
t _{TRANS}	Clock output transition time		4.0		ns	
t _{PULSE}	8kHz input reference pulse width(positive or negative)	30			ns	
T _{OP}	Operating temperature	0		70	°C	

Specifications

Table 4

Parameter	Specifications	Notes
Frequency Range (Sync_Out)	8 kHz to 77.76 MHz	
Frequency Range (Opt_Out)	8 kHz to 77.76 MHz	
Supply Current	250 mA typical, 400 mA during warm-up (Maximum)	
Timing Reference Inputs	8 kHz - 19.44 MHz	3.0
Jitter, Wander and Phase Transient Tolerances	GR-1244-CORE 4.2-4.4, GR-253-CORE 5.4.4.3.6	
Wander Generation	GR-1244-CORE 5.3, GR-253-CORE 5.4.4.3.2	
Wander Transfer	GR-1244-CORE 5.4	
Jitter Generation	GR-1244-CORE 5.5, GR-253-CORE 5.6.2.3	
Jitter Transfer	GR-1244-CORE 5.5, GR-253-CORE 5.6.2.1	
Phase Transients	GR-1244-CORE 5.6, GR-253-CORE 5.4.4.3.3	
Free Run Accuracy	4.6 ppm over T _{OP}	
Hold Over Stability	±0.37 ppm for initial 24 hrs	4.0
Initial Offset	±0.05 ppm	
Temperature	±0.28 ppm	
Drift	±0.04 ppm	
Maximum Hold Over History	40 seconds	
Pull-in/ Hold-in Range	±13.8 ppm minimum	5.0
Lock Time	30 seconds typical	
DPLL Bandwidth	< 0.1 Hz	

NOTES:

- 1.0: Stresses beyond those listed under Absolute Maximum Rating may cause damage to the device. Operation beyond Recommended Conditions is not implied.
- 2.0: Logic is 3.3V CMOS
- 3.0 GR-1244-CORE 3.2.1

- 4.0: Hold Over stability is the cumulative fractional frequency offset as described by GR-1244-CORE, 5.2
- 5.0: Pull-in Range is the maximum frequency deviation from nominal clock rate on the reference inputs to the timing module that can be overcome to pull into synchronization with the reference



Pin Description

Table 5

Pin #	Connection	Description
1	Hold Over	Indicator output. High output when Hold Over mode is selected by control pins.
2	Ref 1	Indicator output. High output when Ref 1 mode is selected by control pins.
3	Ref 2	Indicator output. High output when Ref 2 mode is selected by control pins.
4	Free Run	Indicator output. High output when Free Run mode is selected by control pins.
5	GND	Ground
6	Alarm_Out	Alarm output. High output if module is in Free Run, or Hold Over, or LOR.
7	CNTL A	Mode control input
8	CNTL B	Mode control input
9	PLL_Unlock	Indicates that the PLL is not locked to a reference.
10	Tri-State/GND	0 = Normal operation, 1= Tri-State. Pin is pulled low internally. Ground pin for normal operation.
11	Sync_Out	Primary timing output signal. Signal is synchronized to reference.
12	GND	Ground
13	Opt_Out	Secondary output signal. Signal is derived from Sync_Out or from an internal reference clock depending upon the chosen configuration.
14	GND	Ground
15	Ex_Ref_2	External Input Reference #2
16	GND	Ground
17	Ex_Ref_1	External Input Reference #1
18	Vcc	+5V dc supply

Ordering Information

MSTM-S3-TR-(Input Reference Frequency)(Opt_Out Frequency)-(Primary Output)

1= 1.544 MHz
 2= 2.048 MHz
 8= 8 kHz
 9= 19.44 MHz
 S= Other

Primary Output + N option:
 2= 2.048 MHz
 8= 8 kHz
 N= No output
 S= Other

Reference Clock Out option:
 6= 16.384 MHz
 9= 19.44 MHz

02.048M = 2.048MHz
 016.384M = 16.384 MHz
 019.44M = 19.44 MHz
 032.768M = 32.768 MHz
 038.88 M = 38.88 MHz
 077.76 M = 77.76 MHz

Example: MSTM-S3-TR-88-038.88M

Typical Application

Figure 2

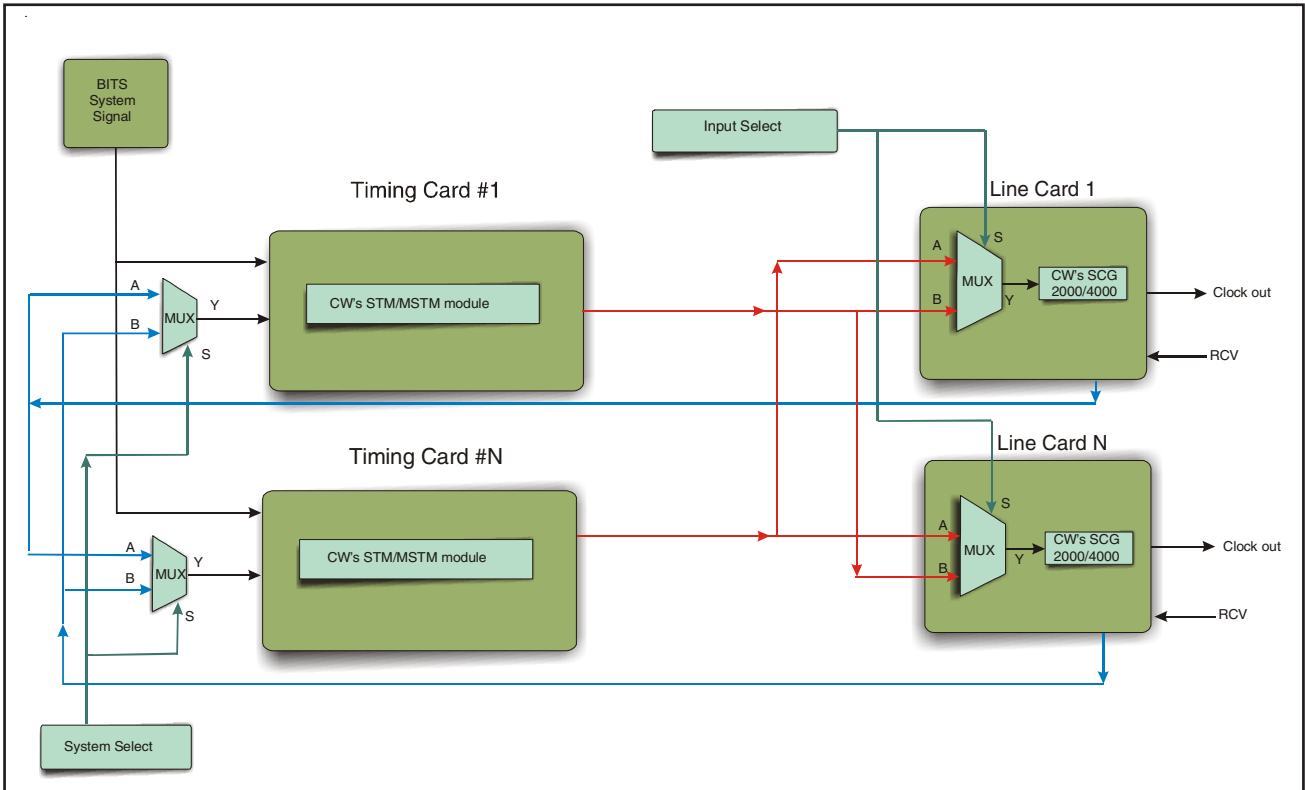

Typical System Test Set-up

Figure 3

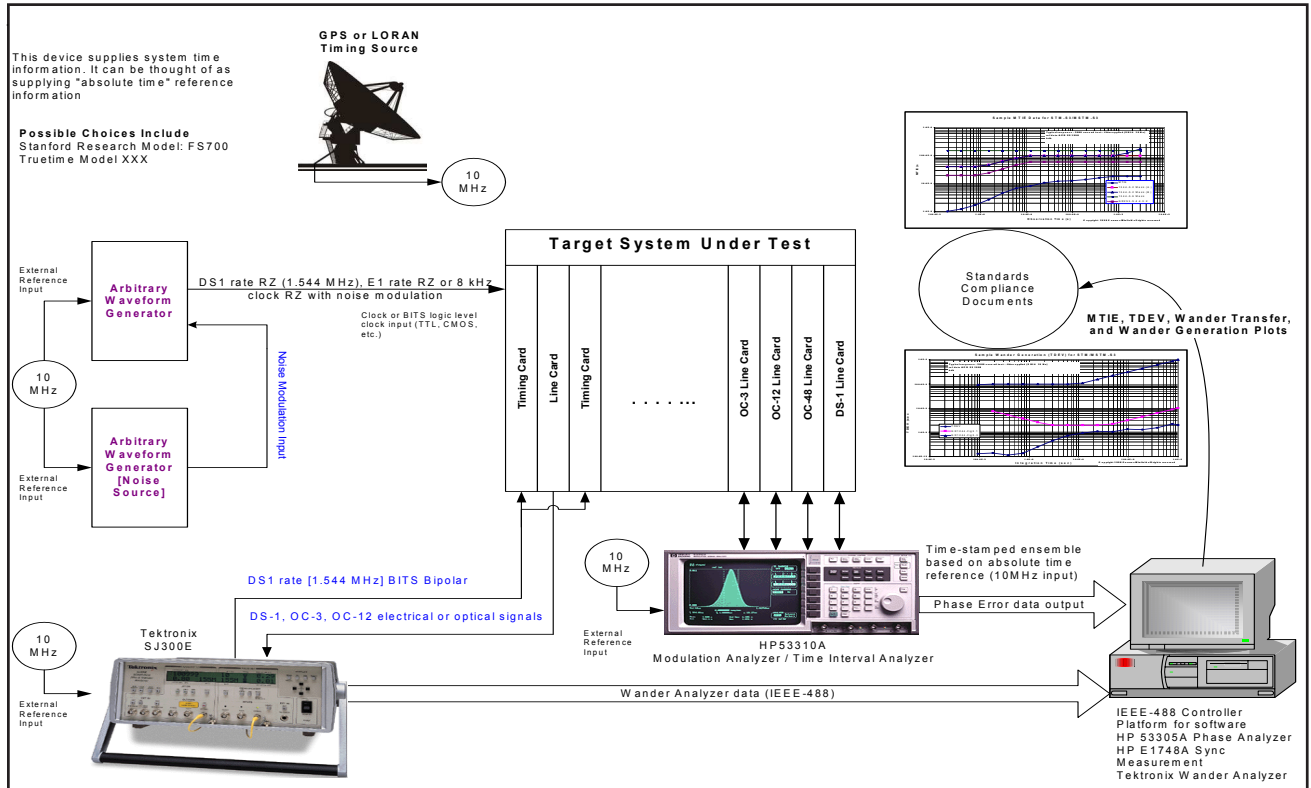

MSTM-S3-TR Typical Current Draw

Figure 4

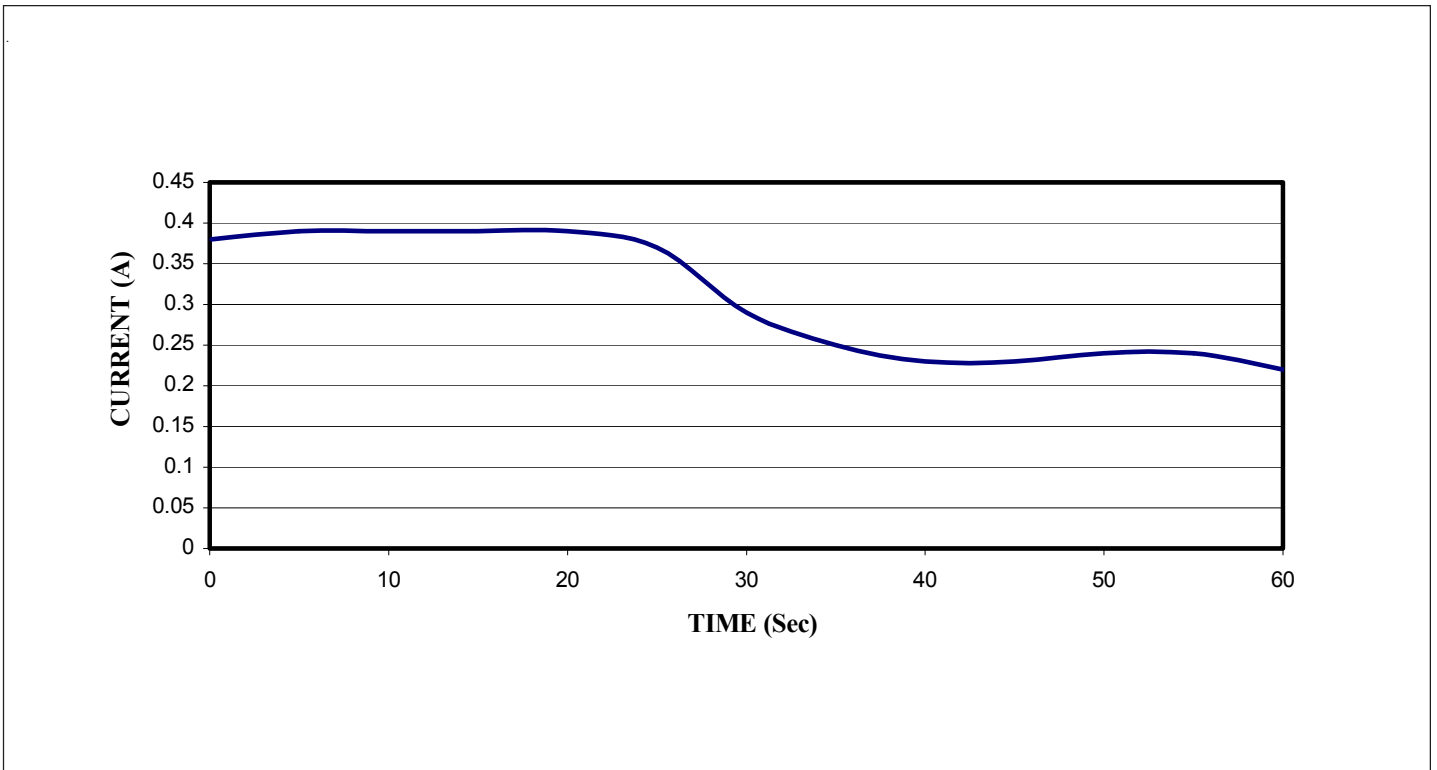

Typical Calibrated Wander Transfer TDEV

Figure 5

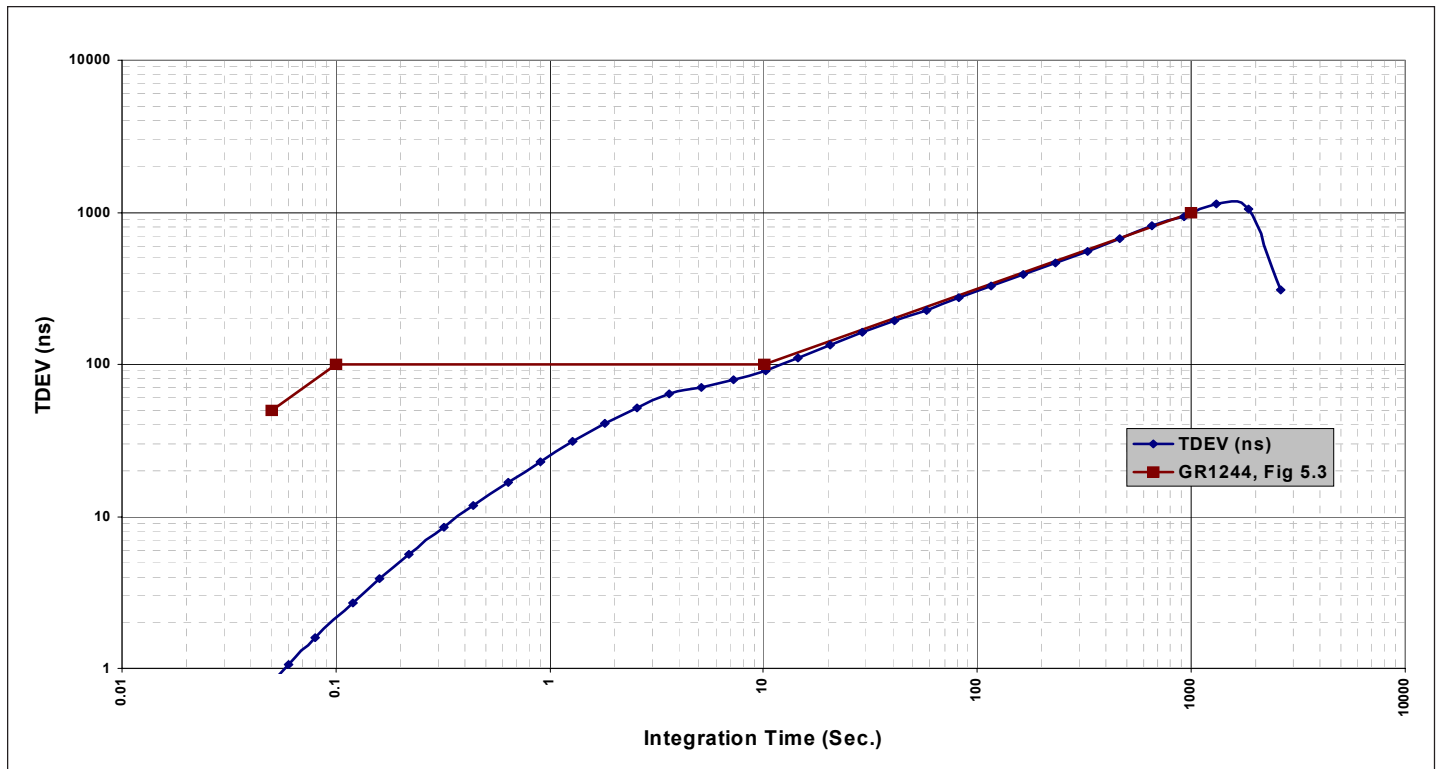

Typical Wander Generation MTIE

Figure 6

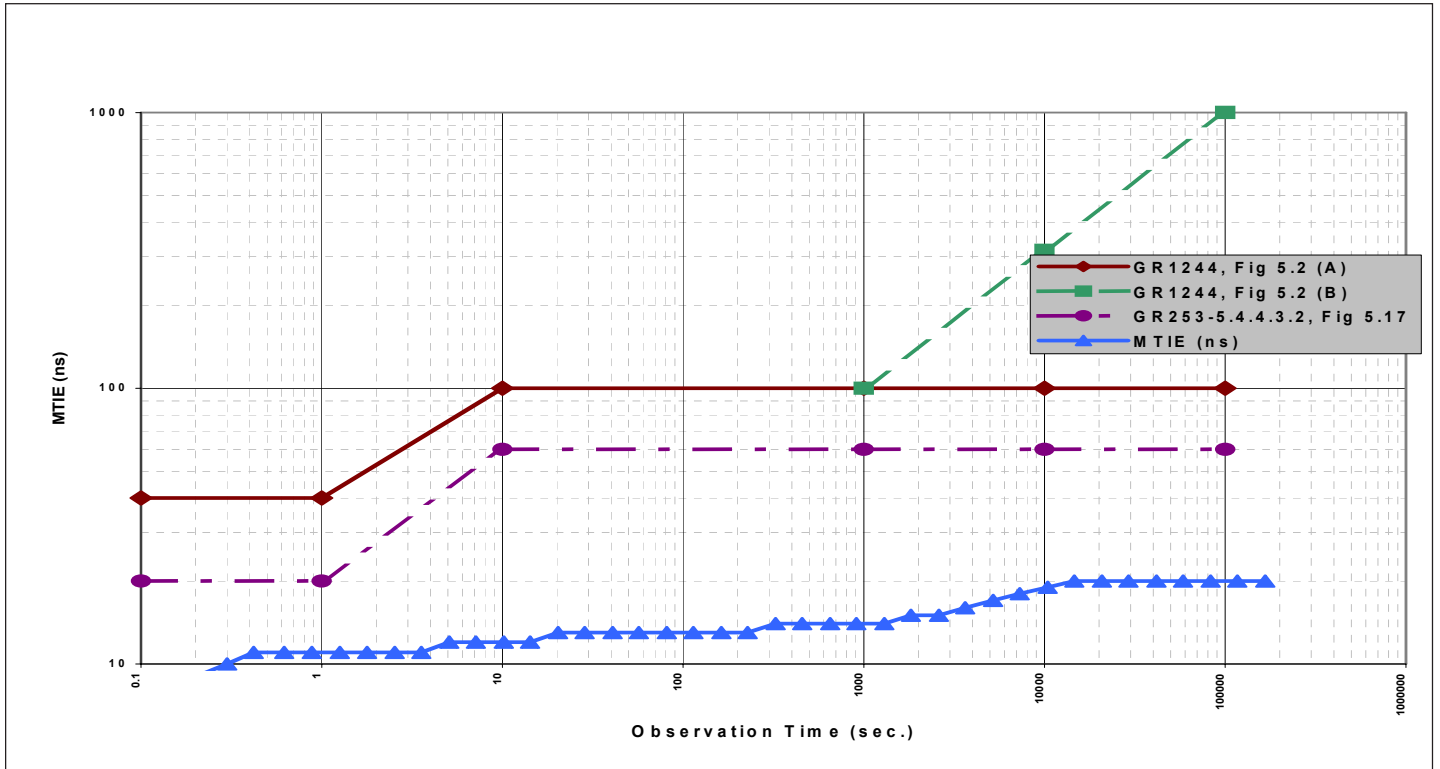

Typical Wander Generation TDEV

Figure 7

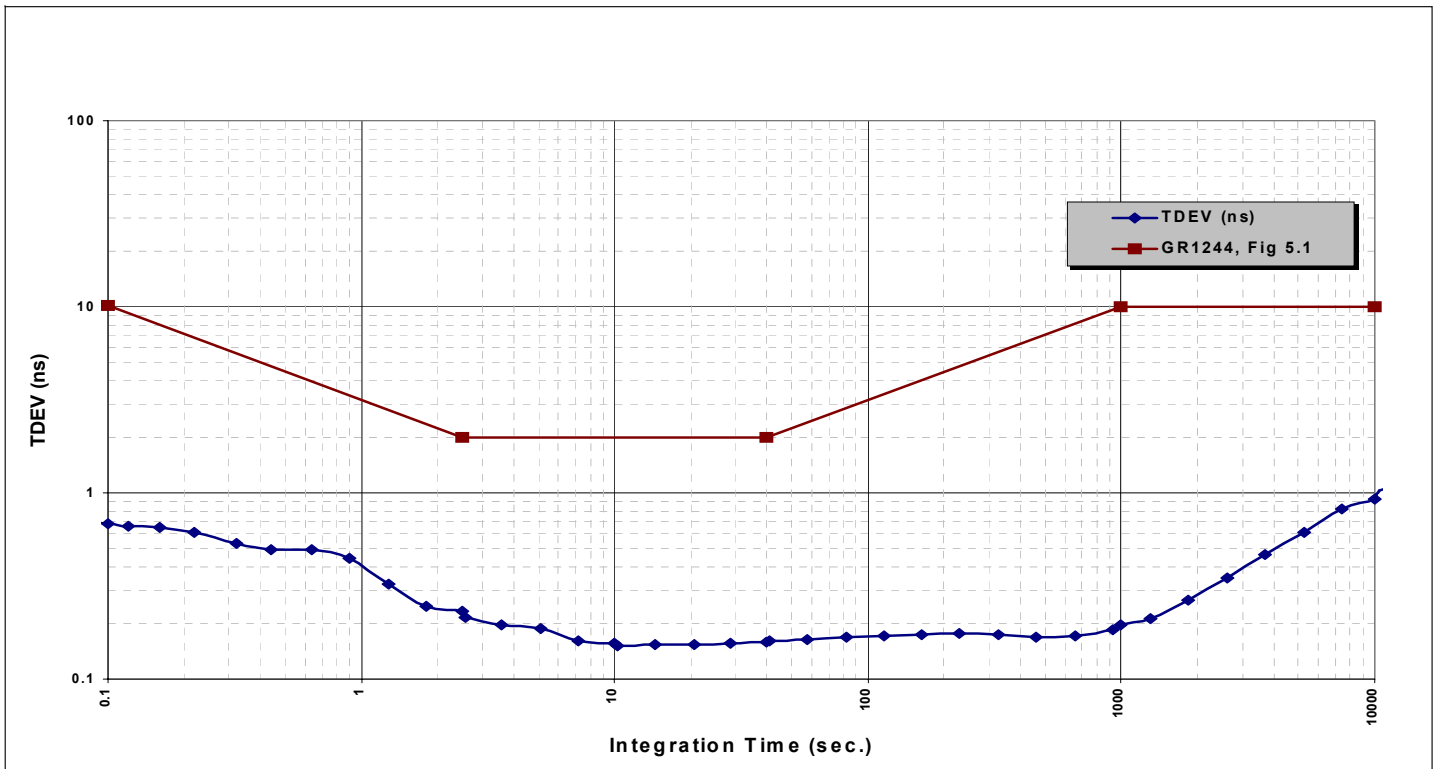

1 μ s Phase Transient TIE

Figure 8

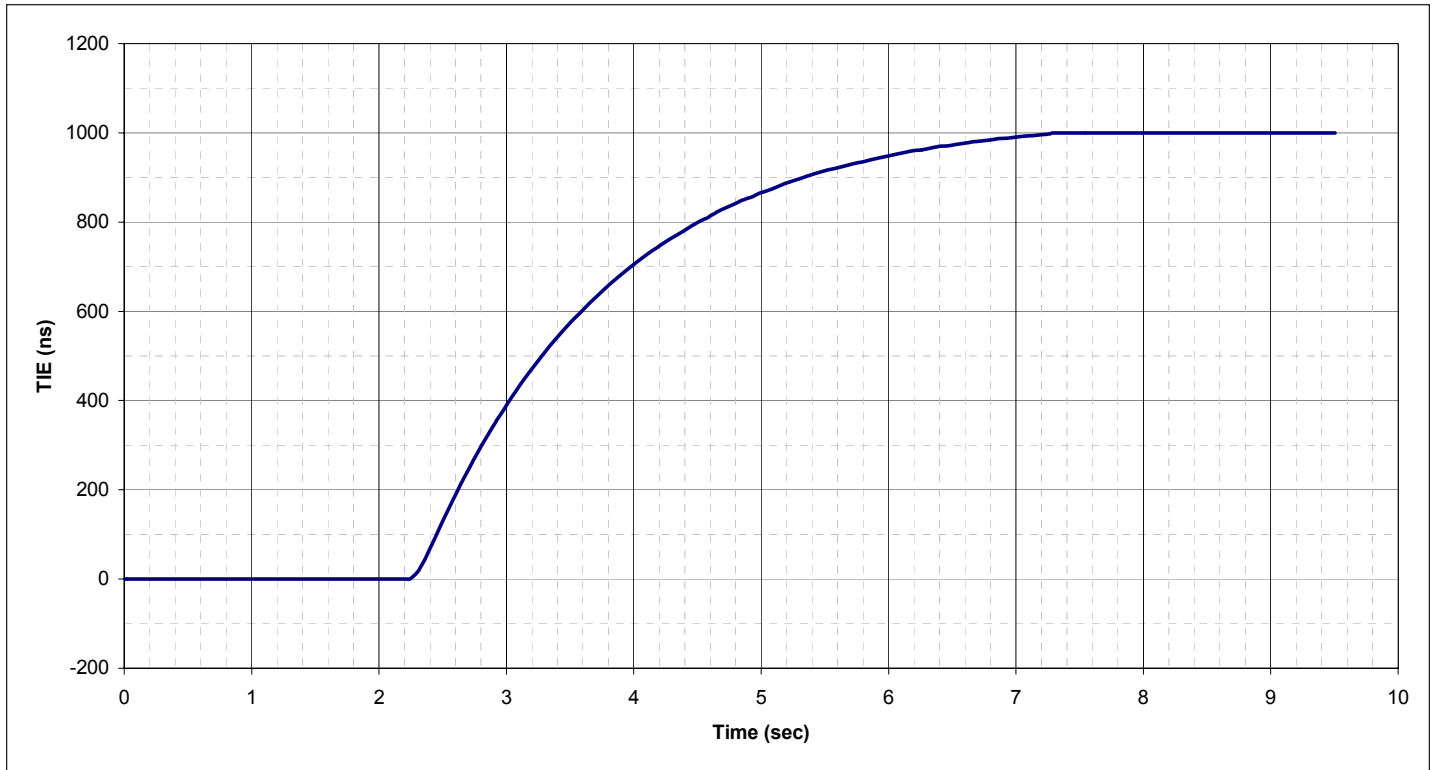

Typical Phase Transient MTIE

Figure 9

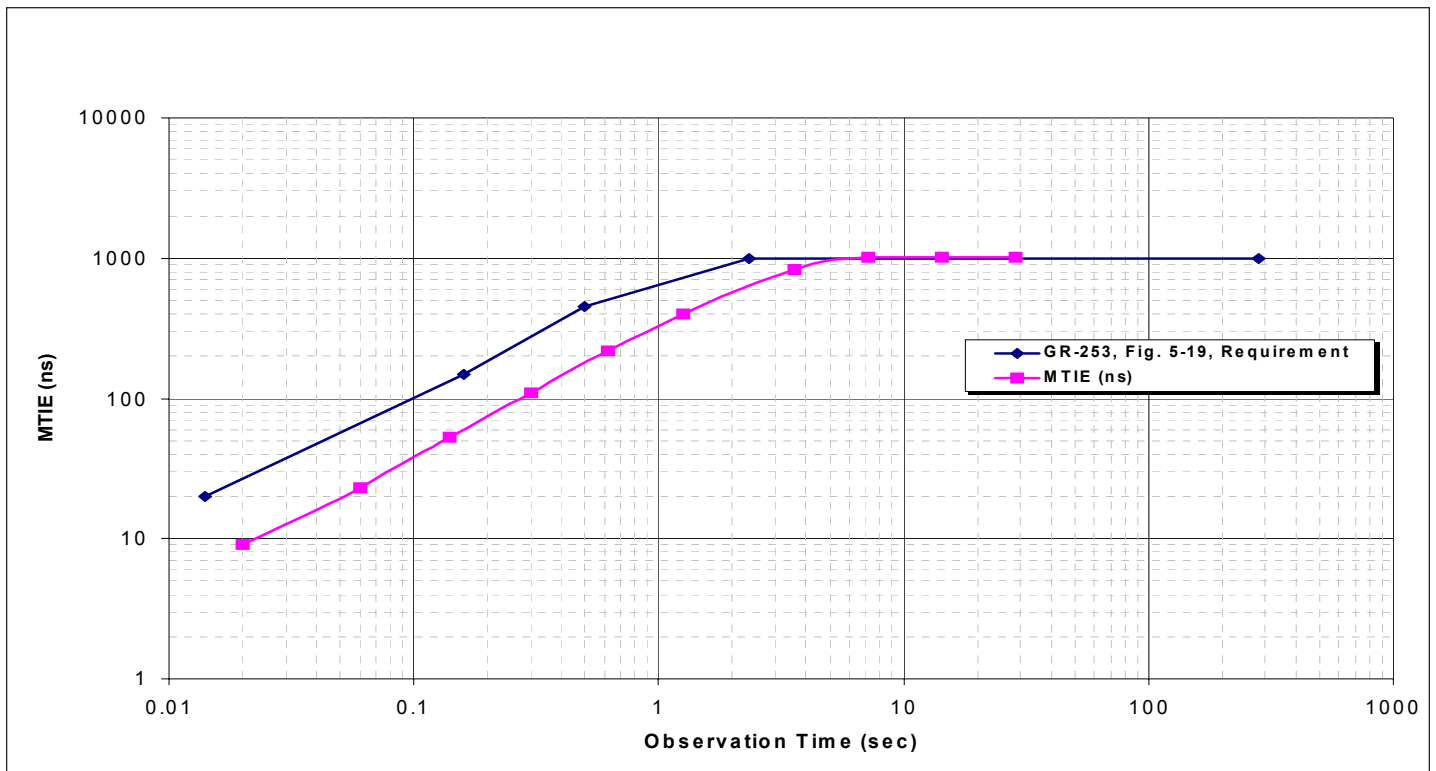

Entry Into Hold Over

Figure 10

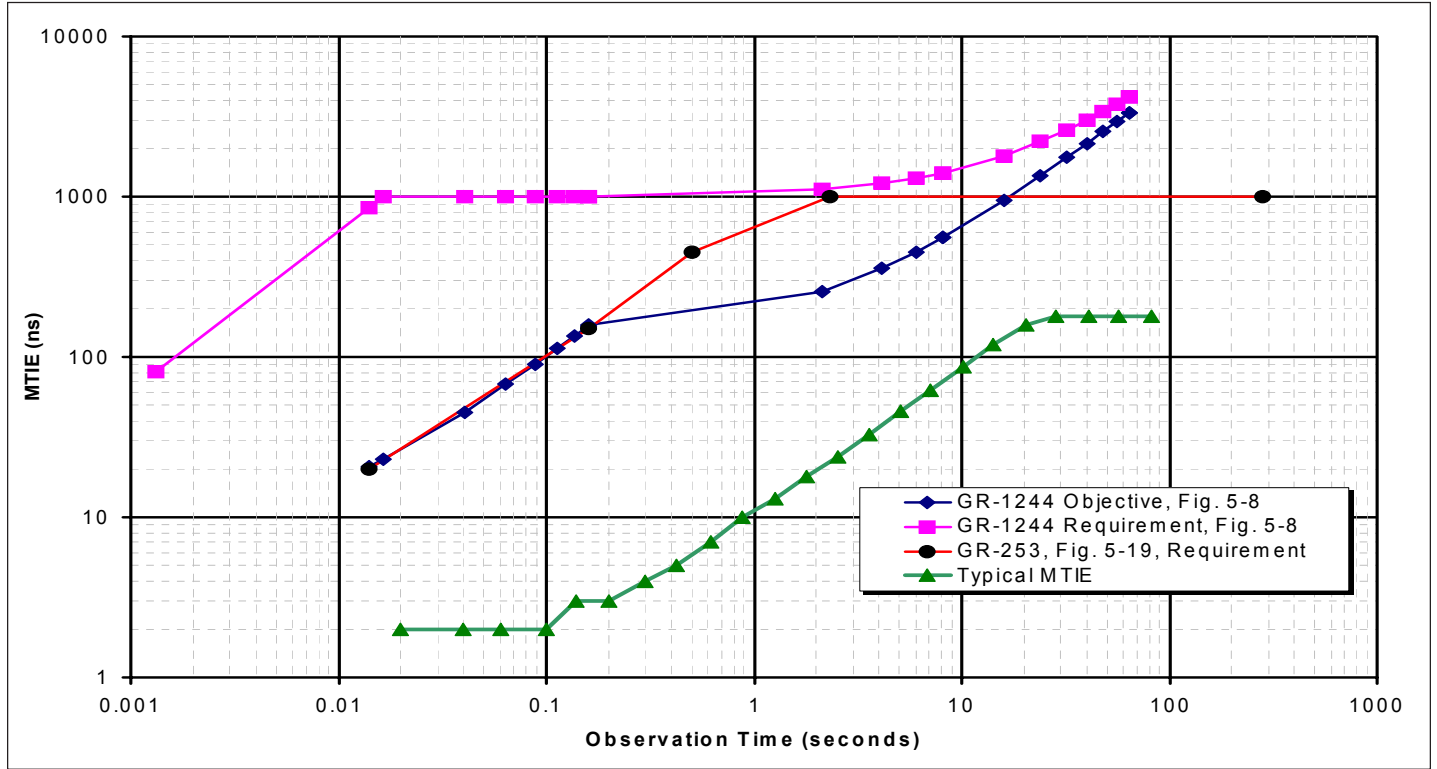

Return from Hold Over

Figure 11

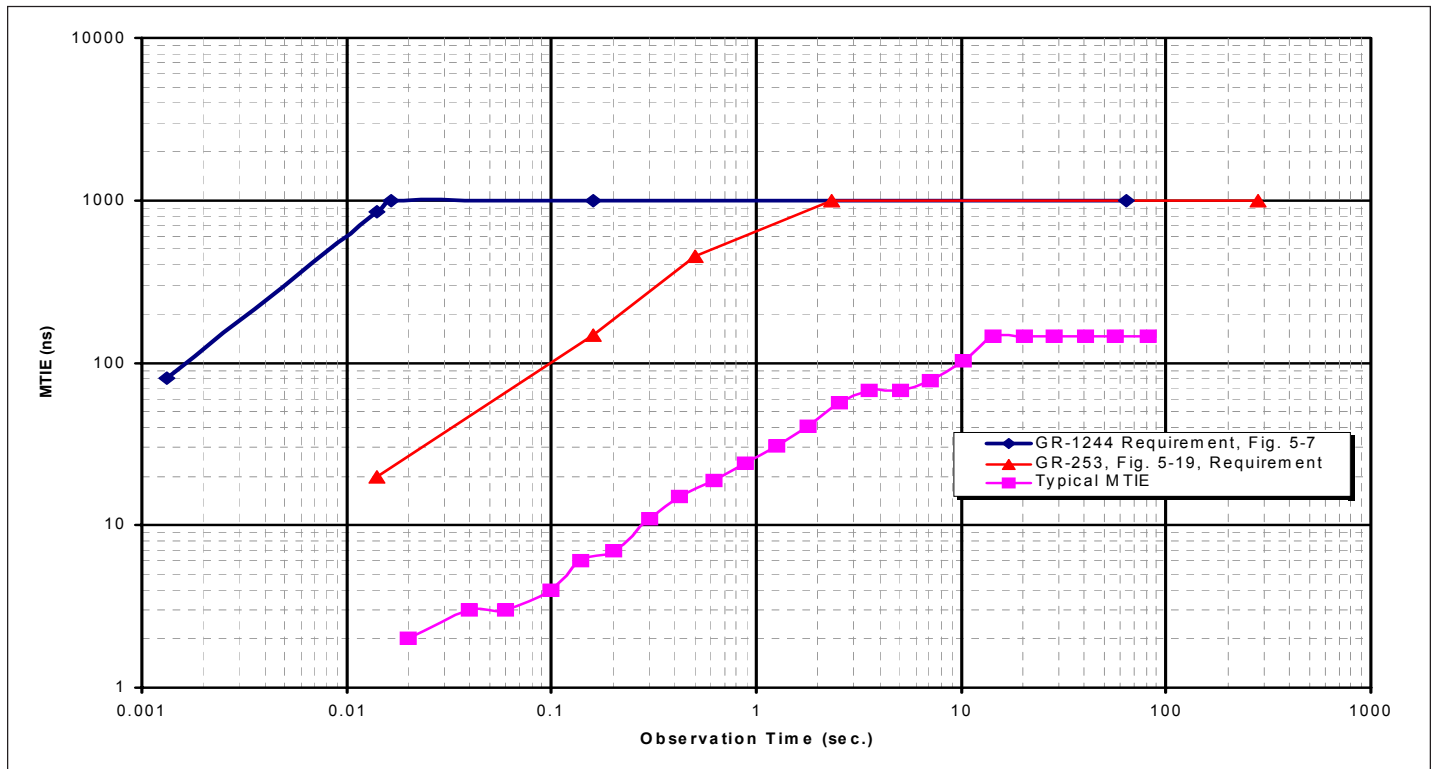

MSTM-S3-TR Mode Indicator Delay

Figure 12

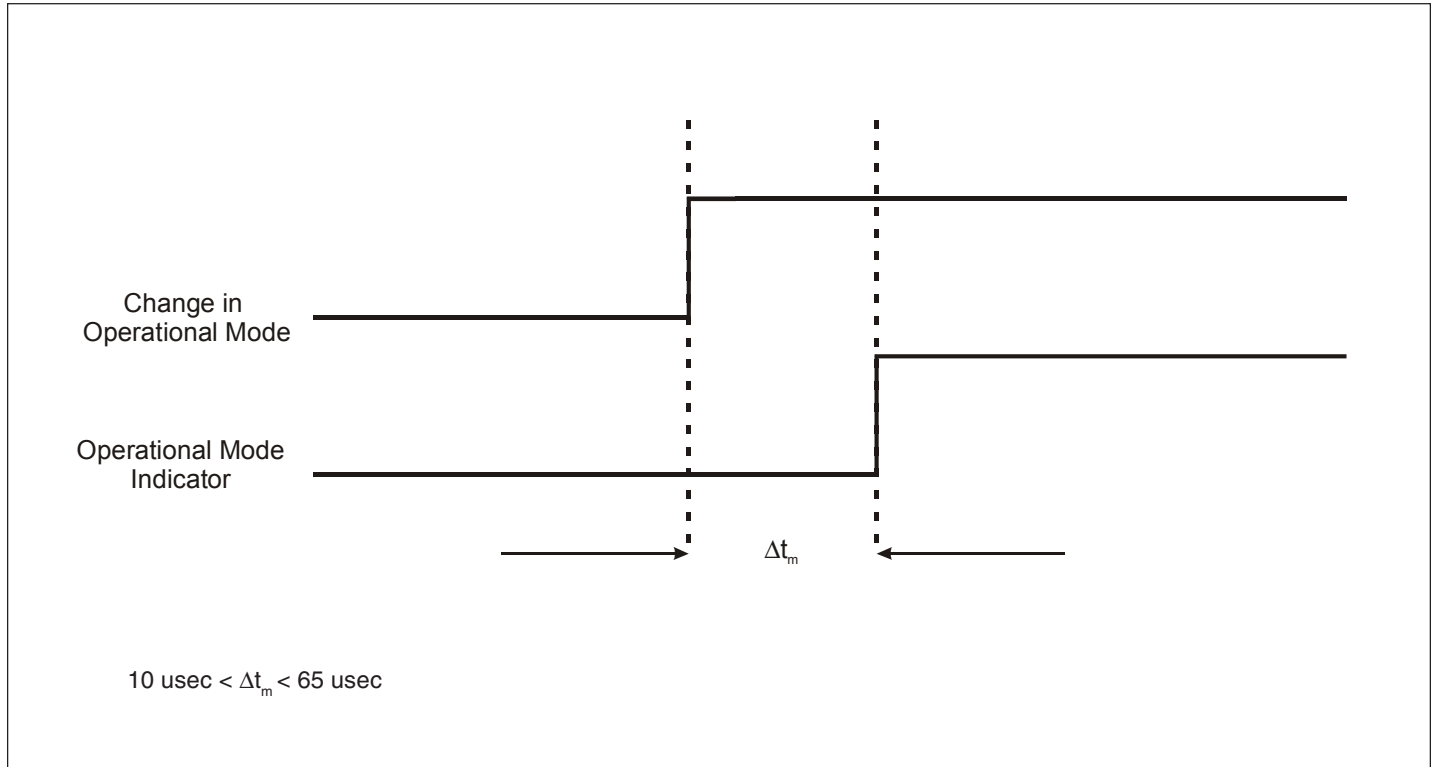

Loss of Reference Timing Diagram

Figure 13

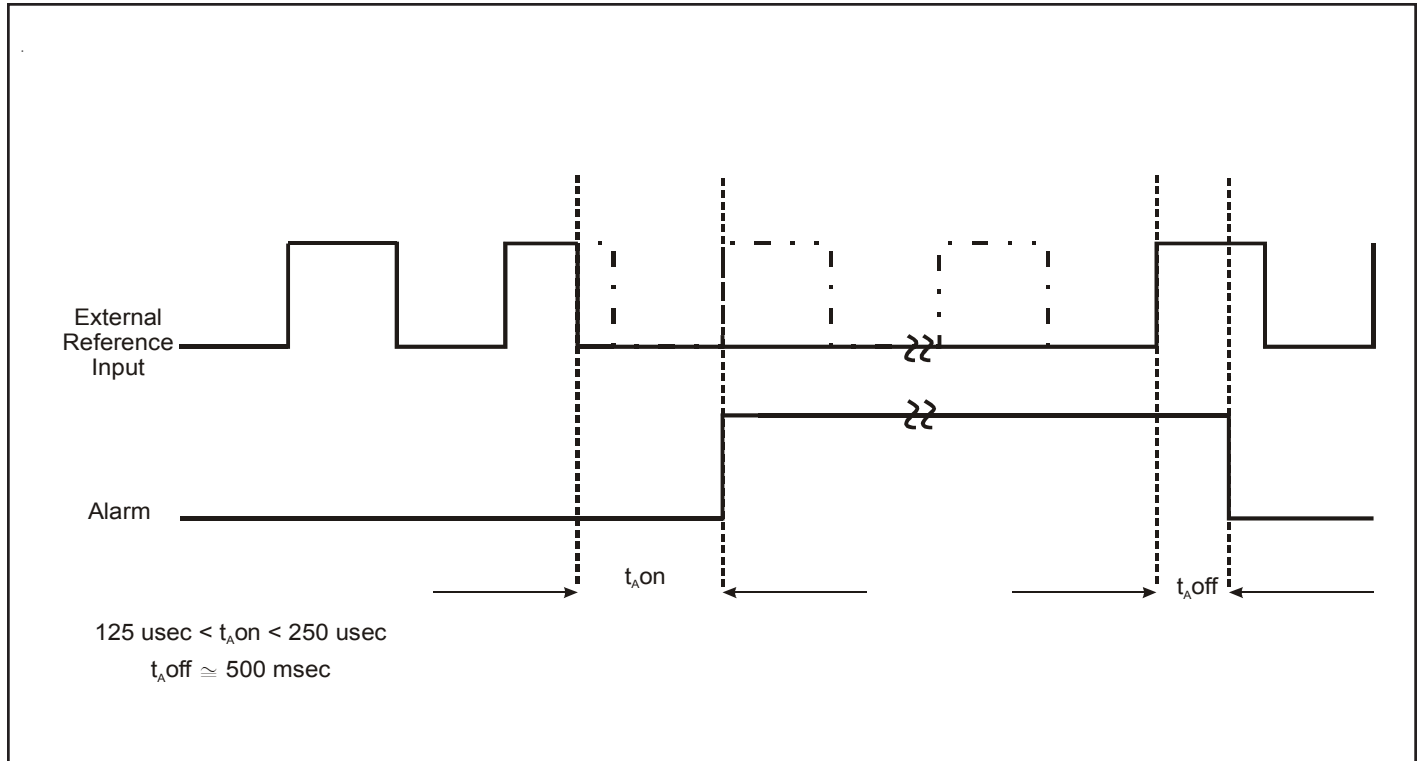

Power on Reset Levels

Figure 14

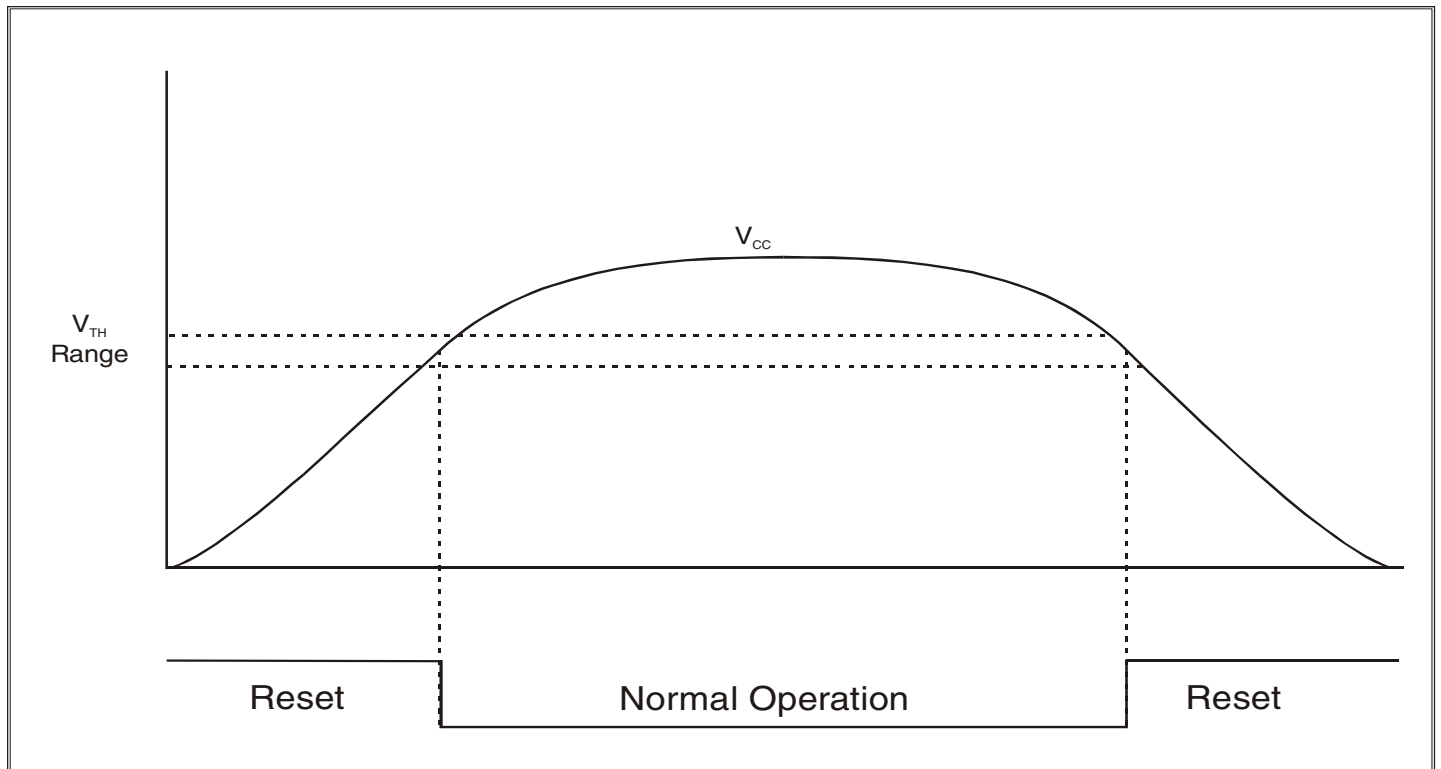

Solder Clearance

Figure 15

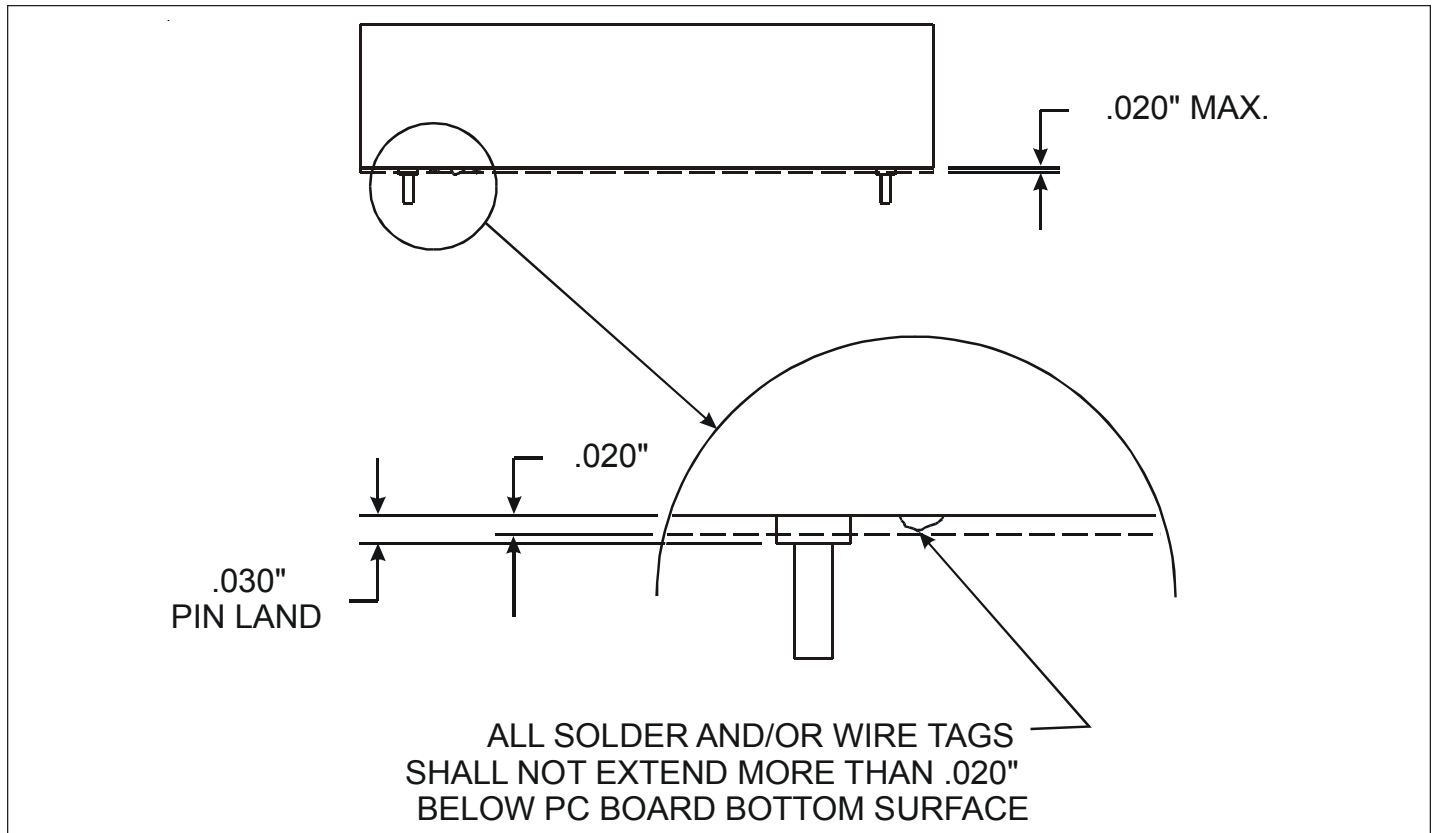

MECHANICAL OUTLINE:

The mechanical outline of the MSTM-S3-TR is shown in Figure 16. The board space required is 2" x 2". The pins are .040" in diameter and are .150" in length. The unit is spaced off the PCB by .030" shoulders on the pins. Due to the height of the device it is recommended to have heat sensitive devices away where the air flow might not be blocked.

PAD ARRAY AND PAD SPACING:

The pins are arranged in a dual-in-line configuration as shown in Figure 17. There is .2" space between the pins in-line and each line is separated by 1.6". See Figures 16 & 17 and Table 6.

PAD CONSTRUCTION:

The recommended pad construction is shown in Figure 17. For the pin diameter of .040" a hole diameter of .055" is suggested for ease of insertion and rework. A pad diameter of .150" is also suggested for support. This leaves a spacing of .050" between the pads which is sufficient for most signal lines to pass through.

SOLDER MASK:

A solder mask is recommended to cover most the top pad to avoid excessive solder underneath the shoulder of the pin to avoid rework damage. See Table 6 and Figure 18.

VIA KEEP OUT AREA:

It is recommended that there be no vias or feed throughs underneath the main body of the module between the pins. It is suggested that the traces in this area be kept to a minimum and protected by a layer of solder mask. See Figure 17.

GROUND AND POWER SUPPLY LINES:

Power specifications will vary depending primarily on the temperature range. At wider temperature ranges starting at 0 to 70 deg. C., an ovenized oscillator, OCXO, will be incorporated. The turn-on current for an OCXO requires a peak current of about .4A for about a minute. The steady state current will vary from 50-150 mA depending on the temperature. It is suggested to plan for the peak current in the power and ground traces pin 18 and pin 5. The other four ground pins 10, 12, 14, and 16 are intended for signal grounds.

POWER SUPPLY REGULATION:

Good power supply regulation is recommended for the MSTM-S3-TR. The internal oscillators are regulated to operate from 4.75 - 5.25 volts. Large jumps within this range may still produce varying degrees of wander. If the host system is subject to large voltage jumps due to hot-swapping and the like, it is suggested that there be some form of external regulation such as a DC/DC converter.

SOLDERING RECOMMENDATIONS:

Due to the sensitive nature of this part, hand soldering or wave soldering of the pins is recommended after reflow processes.

WASHING RECOMMENDATIONS:

The MSTM-S3-TR is not in a hermetic enclosure. It is recommended that the leads be hand cleaned after soldering. Do not completely immerse the module.

MODULE BAKEOUT:

Do not bakeout the MSTM-S3-TR

Package Dimensions

Figure 16

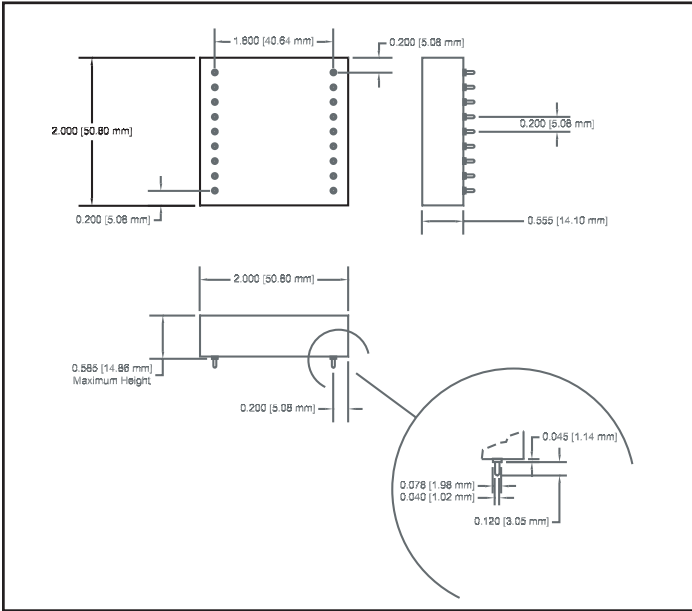

Characteristic Measurements

Table 6

Characteristic Item	Measurement (inches)
Pad to Pad Spacing	0.200
Solder pad top O.D.	0.150
Solder pad top I.D.	0.055
Solder pad bottom O.D.	0.150
Solder pad bottom I.D.	0.055
Solder mask top dia.	0.070
Solder mask bottom dia.	0.155
Pin row to row spacing	1.600

Recommended Footprint Dimensions

Figure 17

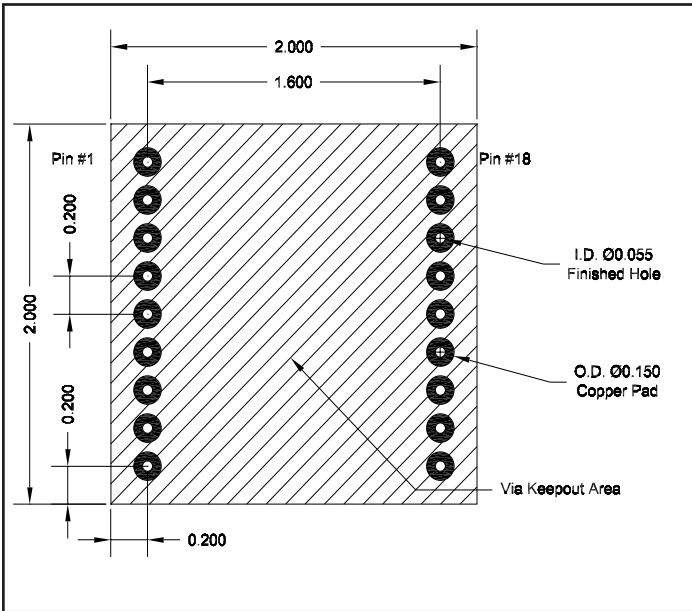

Side Assembly View

Figure 18

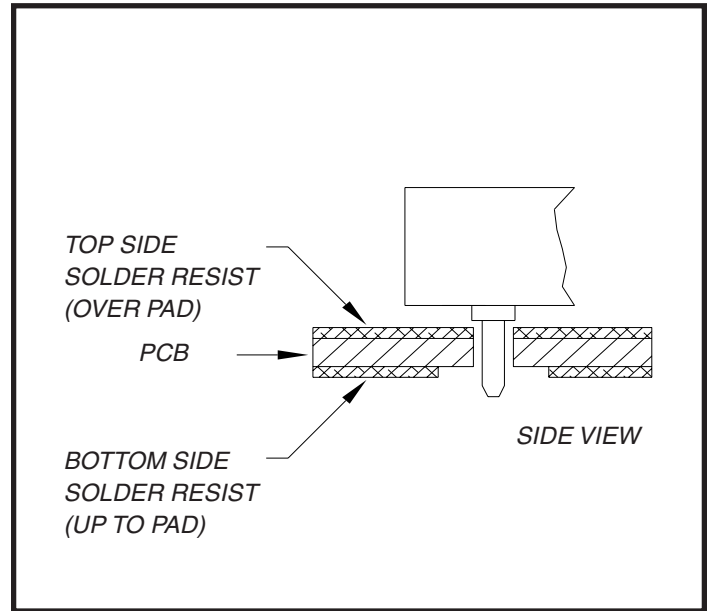

Revision	Revision Date	Note
P00	7/27/01	Preliminary Release
P01	8/01/01	Added POR figure and Tri-state pin
P02	8/14/01	Added new input frequency
P03	4/9/02	Added Opt_Out information
P04	4/9/02	Updated Pin descriptions
P05	12/2/02	Corrected Table 1



2111 Comprehensive Drive
Aurora, Illinois 60505
Phone: 630-851-4722
Fax: 630-851-5040
www.conwin.com