

CHS80

CH S 80 48 05 - □

① ② ③ ④ ⑤ ⑥



RoHS

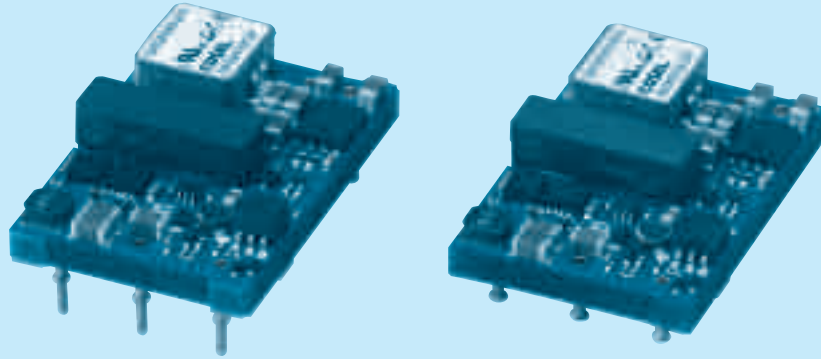

- ① Series name
- ② Single output
- ③ Output power
80:80W
- ④ Input voltage
48:DC36-76V
- ⑤ Output voltage
3R3:3.3V
05:5.0V
12:12V
- ⑥ Optional
R :with Remote ON/OFF
Positive logic control
U :Shut down in protection
circuit working
S :SMD

MODEL	CHS80483R3	CHS804805	CHS804812
MAX OUTPUT WATTAGE[W]	82.5	80.0	90.0
DC OUTPUT	3.3V 25A	5.0V 16A	12V 7.5A

SPECIFICATIONS

	MODEL	CHS80483R3	CHS804805	CHS804812	
INPUT	VOLTAGE[V]	DC36 - 76			
	CURRENT[A]	*1 1.86typ	1.81typ	2.03typ	
	EFFICIENCY[%]	*1 92typ	92typ	92typ	
OUTPUT	VOLTAGE[V]	3.3	5	12	
	CURRENT[A]	25	16	7.5	
	LINE REGULATION[mV]	±10max			
	LOAD REGULATION[mV]	±10max			
	RIPPLE	[mVrms] *2	30max	30max	50max
		[mVp-p] *2	80max	100max	150max
	RIPPLE NOISE[mVp-p] *2	120max	150max	180max	
	TEMPERATURE REGULATION[mV]	66max	100max	240max	
	DRIFT[mV] *3	16max	20max	40max	
	START-UP TIME[ms]	200max (DCIN 48V, Io=100%)			
	OUTPUT VOLTAGE ADJUSTMENT RANGE *4	Fixed (TRM pin open), adjustable by external resistor			
OUTPUT VOLTAGE SETTING	-10% / +15%				
OUTPUT VOLTAGE SETTING	-10% / +20%				
OUTPUT VOLTAGE SETTING	-10% / +10%				
PROTECTION CIRCUIT AND OTHERS	OVERCURRENT PROTECTION	Works over 105% of rating (Auto restart)			
	OVERVOLTAGE PROTECTION	120% - 140% (Auto restart)	125% - 145% (Auto restart)	115% - 135% (Auto restart)	
	REMOTE SENSING	Provided			
	REMOTE ON/OFF	Provided (Negative logic L:ON, H:OFF)			
ISOLATION	INPUT-OUTPUT	DC2,250V or AC1,000V 1minute. Cutoff current = 10mA, DC500V 50M Ω min (20±15°C)			
ENVIRONMENT	OPERATING TEMP.,HUMID.AND ALTITUDE	-40 to +85°C, 20 - 95%RH (Non condensing) (Refer to DERATING CURVE), 3,000m (10,000feet) max			
	STORAGE TEMP.,HUMID.AND ALTITUDE	-40 to +100°C, 20 - 95%RH (Non condensing), 9,000m (30,000feet) max			
	VIBRATION	10 - 55Hz, 49.0m/s ² (5G), 3minutes period, 60minutes each along X, Y and Z axis			
	IMPACT	196.1m/s ² (20G), 11ms, once each along X, Y and Z axis			
SAFETY	AGENCY APPROVALS	UL60950-1, C-UL (CSA60950-1), EN60950-1			
OTHERS	CASE SIZE/WEIGHT	33.0 × 10.5 × 22.76mm [1.3 × 0.41 × 0.9 inches] (W×H×D) / 21g max			
	COOLING METHOD	Convection / Forced air			

*1 At rated input(DC48V) and rated load. Ta=25°C, 2m/s.

*2 Ripple and ripple noise is measured by using measuring board with ceramic capacitor 22 μ F.

*3 Drift is the change in DC output for an eight hour period after a half-hour warm-up at 25°C, with the input voltage held constant at the rated input/output.

*4 Refer to the instruction manual for input voltage derating.

External view

1. DIP

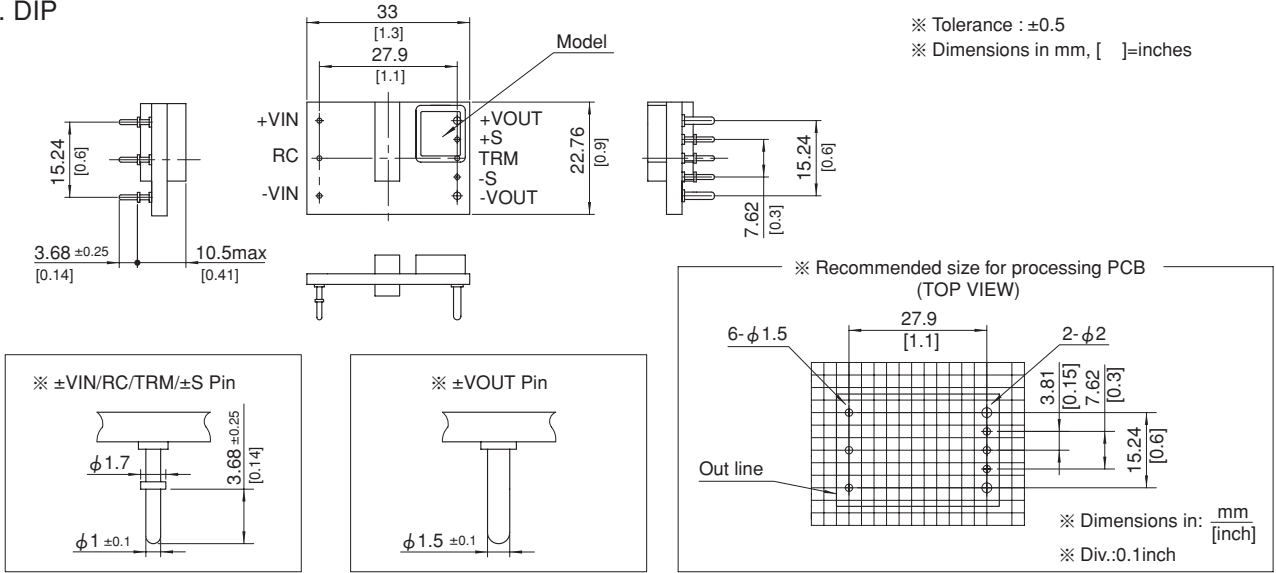

2. SMD (optionS)

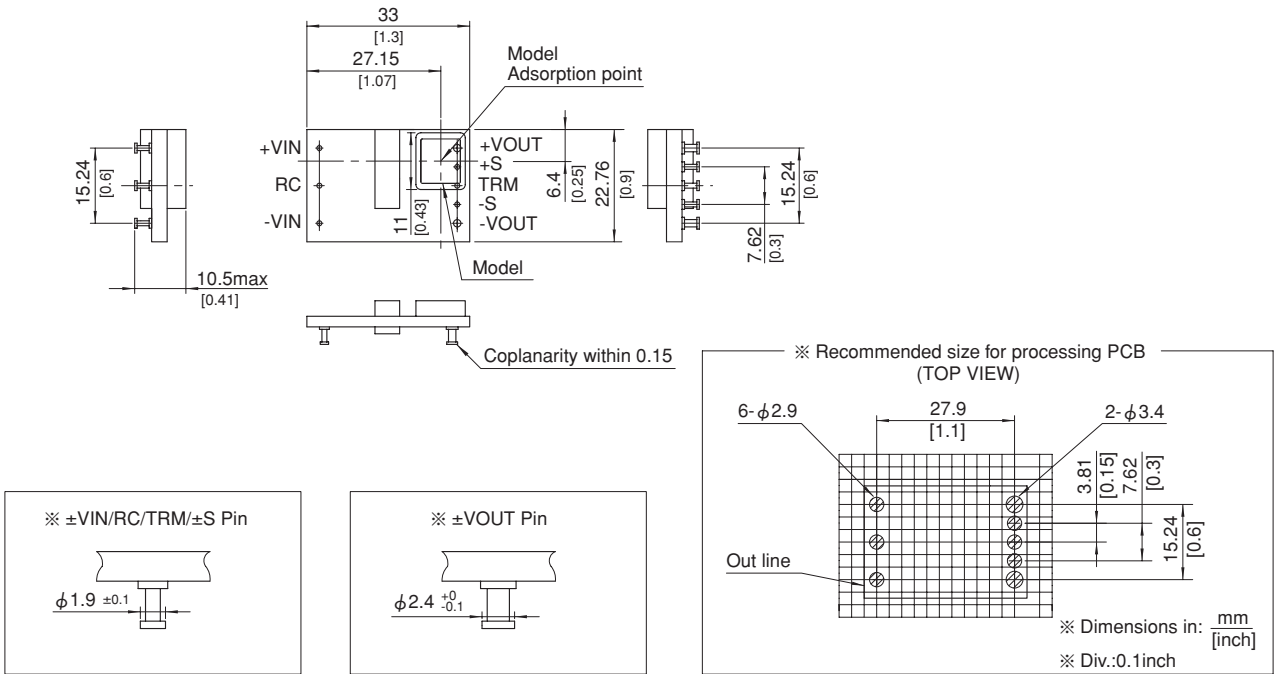

CHS200

CH S 200 48 05 - □

① ② ③ ④ ⑤ ⑥



RoHS

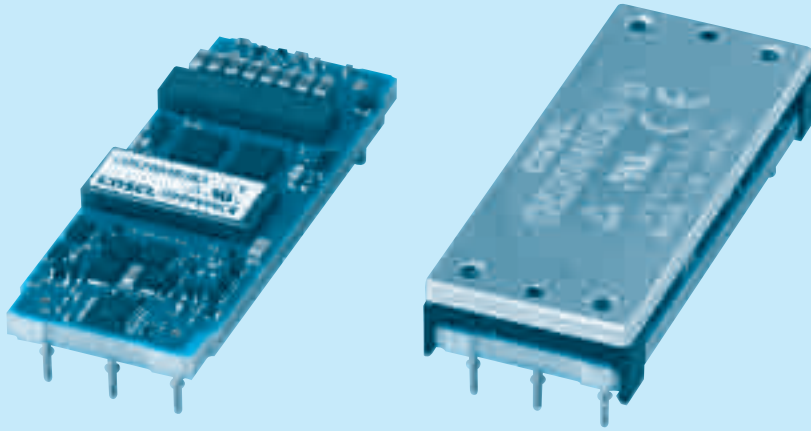

- ① Series name
- ② Single output
- ③ Output power
200:200W
- ④ Input voltage
48:DC36-76V
- ⑤ Output voltage
3R3:3.3V
05:5.0V
12:12V
- ⑥ Optional
R :with Remote ON/OFF
Positive logic control
U :Shut down in protection
circuit working
B :BasePlate option with
Mounting hole M3
L2:Pin length 5.3mm
L5:5pins option
(+S,-S,TRM less)

MODEL	CHS200483R3	CHS2004805	CHS2004812
MAX OUTPUT WATTAGE[W]	165.0	200.0	192.0
DC OUTPUT	3.3V 50A	5.0V 40A	12V 16A

SPECIFICATIONS

	MODEL	CHS200483R3	CHS2004805	CHS2004812	
INPUT	VOLTAGE[V]	DC36 - 76			
	CURRENT[A]	*1 3.70typ	4.43typ	4.26typ	
	EFFICIENCY[%]	*1 93typ	94typ	94typ	
OUTPUT	VOLTAGE[V]	3.3	5	12	
	CURRENT[A]	50	40	16	
	LINE REGULATION[mV]	±10max			
	LOAD REGULATION[mV]	±10max			
	RIPPLE	[mVrms] *2	30max	30max	50max
		[mVp-p] *2	80max	100max	150max
	RIPPLE NOISE[mVp-p]	*2 120max	150max	180max	
	TEMPERATURE REGULATION[mV]	66max	100max	240max	
	DRIFT[mV]	*3 16max	20max	40max	
	START-UP TIME[ms]	200max (DCIN 48V, Io=100%)			
OUTPUT VOLTAGE ADJUSTMENT RANGE	*4 Fixed (TRM pin open), adjustable by external resistor -10% / +15%		-10% / +20%	-10% / +10%	
OUTPUT VOLTAGE SETTING	±1.6%				
PROTECTION CIRCUIT AND OTHERS	OVERCURRENT PROTECTION	Works over 105% of rating (Auto restart)			
	OVERVOLTAGE PROTECTION	120% - 140% (Auto restart)	125% - 145% (Auto restart)	115% - 135% (Auto restart)	
	REMOTE SENSING	Provided			
	REMOTE ON/OFF	Provided (Negative logic L:ON, H:OFF)			
ISOLATION	INPUT-OUTPUT	DC2,250V or AC1,000V 1minute, Cutoff current = 10mA, DC500V 50MΩ min (20±15°C)			
	INPUT-BASEPLATE	*5 DC2,250V or AC1,000V 1minute, Cutoff current = 10mA, DC500V 50MΩ min (20±15°C)			
	OUTPUT-BASEPLATE	*5 AC500V 1minute, Cutoff current = 10mA, DC500V 50MΩ min (20±15°C)			
ENVIRONMENT	OPERATING TEMP.,HUMID.AND ALTITUDE	-40 to +85°C, 20 - 95%RH (Non condensing) (Refer to DERATING CURVE), 3,000m (10,000feet) max			
	STORAGE TEMP.,HUMID.AND ALTITUDE	-40 to +100°C, 20 - 95%RH (Non condensing), 9,000m (30,000feet) max			
	VIBRATION	10 - 55Hz, 49.0m/s ² (5G), 3minutes period, 60minutes each along X, Y and Z axis			
	IMPACT	196.1m/s ² (20G), 11ms, once each along X, Y and Z axis			
SAFETY	AGENCY APPROVALS	UL60950-1, C-UL (CSA60950-1), EN60950-1			
OTHERS	CASE SIZE/WEIGHT	57.9 × 10.5 × 22.76mm [2.28 × 0.41 × 0.9 inches] (W × H × D) / 30g max			
	COOLING METHOD	58.4 × 12.7 × 23.26mm [2.3 × 0.5 × 0.92 inches] (W × H × D) / 45g max *5			
	COOLING METHOD	Convection / Forced air / Conduction			

*1 At rated input(DC48V) and rated load. Ta=25°C, 2m/s.

*2 Ripple and ripple noise is measured by using measuring board with ceramic capacitor 22 μF.

*3 Drift is the change in DC output for an eight hour period after a half-hour warm-up at 25°C, with the input voltage held constant at the rated input/output.

*4 Refer to the instruction manual for input voltage derating.

*5 BasePlate Option.

External view

1. DIP

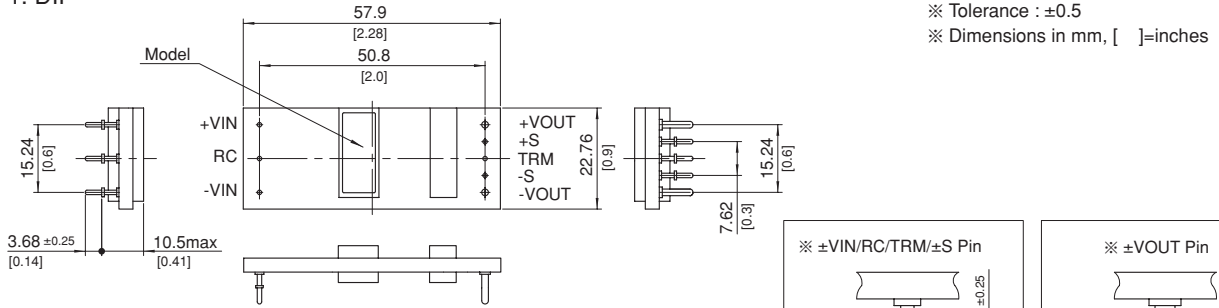

2. BasePlate (optionB)

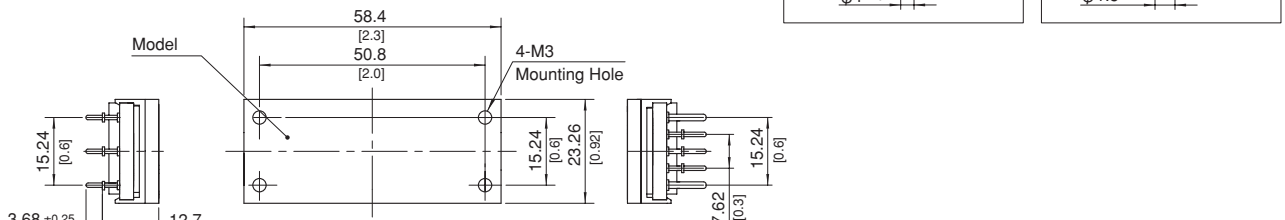

3. 5pins type (option L5)

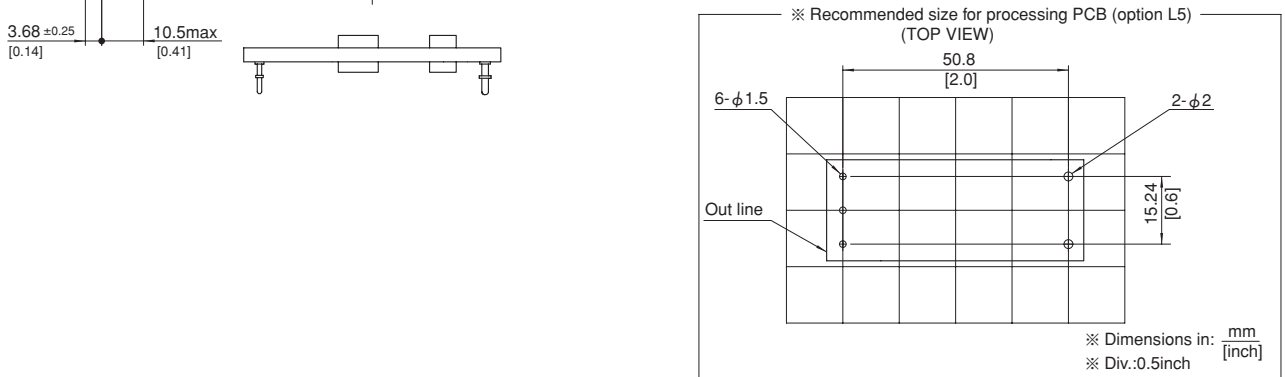
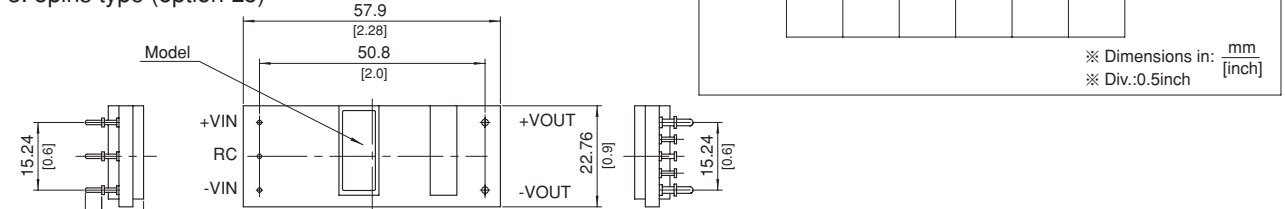

CHS300

CH S 300 48 10 - □

① ② ③ ④ ⑤ ⑥

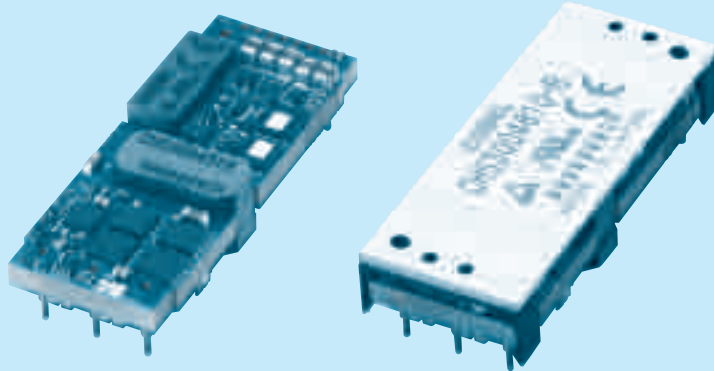
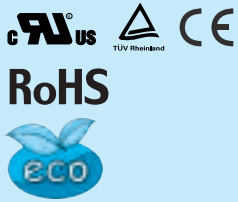

- ① Series name
- ② Single output
- ③ Output power
300:300W
- ④ Input voltage
48:DC36 - 76V
- ⑤ Output voltage
10:10V
12:12V
12H:12V (High efficiency type)
- ⑥ Optional
R :with Remote ON/OFF
Positive logic control
U :Shut down in protection
circuit working
B :BasePlate option with
Mounting hole M3
L2:Pin length 5.3mm
L5:5pins option
(+S,-S,TRM less)

MODEL	CHS3004810	CHS3004812	CHS3004812H
MAX OUTPUT WATTAGE[W]	300.0	300.0	300.0
DC OUTPUT	10V 30A	12V 25A	12V 25A

SPECIFICATIONS

	MODEL	CHS3004810	CHS3004812	CHS3004812H	
INPUT	VOLTAGE[V]	DC36 - 76			
	CURRENT[A] *1	6.61typ	6.61typ	6.55typ	
	EFFICIENCY[%] *1	94.5typ	94.5typ	95.5typ	
OUTPUT	VOLTAGE[V]	10	12	12	
	CURRENT[A]	30	25	25	
	LINE REGULATION[mV] *6	20max	24max	24max	
	LOAD REGULATION[mV] *6	20max	24max	24max	
	RIPPLE	[mVrms] *2	40max	50max	50max
		[mVp-p] *2	120max	150max	150max
	RIPPLE NOISE[mVp-p] *2	150max	180max	180max	
	TEMPERATURE REGULATION[mV]	200max	240max	240max	
	DRIFT[mV] *3	30max	40max	40max	
	START-UP TIME[ms]	50max (DCIN 48V, Io=100%)			
OUTPUT VOLTAGE ADJUSTMENT RANGE *4	Fixed (TRM pin open), adjustable by external resistor -10% / +10%				
OUTPUT VOLTAGE SETTING *1	±1.6%				
PROTECTION CIRCUIT AND OTHERS	OVERCURRENT PROTECTION	Works over 105% of rating (Auto restart)			
	OVERVOLTAGE PROTECTION	115% - 135% (Auto restart)			
	REMOTE SENSING	Provided			
	REMOTE ON/OFF	Provided (Negative Logic L : ON, H :OFF)			
ISOLATION	INPUT-OUTPUT	DC2,250V or AC1,000V 1minute, Cutoff current = 10mA, DC500V 50MΩ min (20±15°C)			
	INPUT-BASEPLATE *5	DC2,250V or AC1,000V 1minute, Cutoff current = 10mA, DC500V 50MΩ min (20±15°C)			
	OUTPUT-BASEPLATE *5	AC500V 1minute, Cutoff current = 100mA, DC500V 50MΩ min (20±15°C)			
ENVIRONMENT	OPERATING TEMP.,HUMID.AND ALTITUDE	-40 to +85°C, 20 - 95%RH (Non condensing) (Refer to DERATING CURVE), 5,000m (16,000 feet) max			
	STORAGE TEMP.,HUMID.AND ALTITUDE	-40 to +100°C, 20 - 95%RH (Non condensing), 9,000m (30,000 feet) max			
	VIBRATION	10 - 55Hz, 49.0m/s ² (5G), 3minutes period, 60minutes each along X, Y and Z axis			
	IMPACT	196.1m/s ² (20G), 11ms, once each along X, Y and Z axis			
SAFETY	AGENCY APPROVALS	UL60950-1, C-UL (CSA60950-1), EN60950-1			
OTHERS	CASE SIZE/WEIGHT	58.4 × 11.0 × 22.86mm [2.3 × 0.43 × 0.9 inches] (W × H × D) / 38g max			
	COOLING METHOD	58.9 × 12.7 × 23.3mm [2.32 × 0.5 × 0.92 inches] (W × H × D) / 50g max *5			
		Convection / Forced air / Conduction			

*1 At rated input (DC48V) and rated load. Ta=25°C, 2m/s.
 *2 Ripple and ripple noise is measured by using measuring board with ceramic capacitor 22 μF.
 *3 Drift is the change in DC output for an eight hour period after a half-hour warm-up at 25°C, with the input voltage held constant at the rated input/output.
 *4 Refer to the instruction manual for input voltage derating.
 *5 BasePlate Option.
 *6 At input voltage DC36 - 76V (CHS3004810, CHS3004812), DC40 - 76V (CHS3004812H).

External view

1. DIP

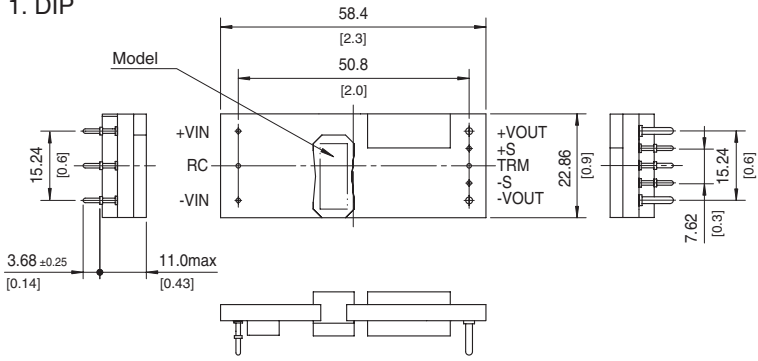

※ Tolerance: ±0.5
※ Dimensions in mm, []=inches

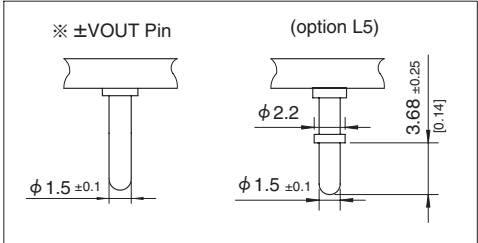

2. BasePlate (optionB)

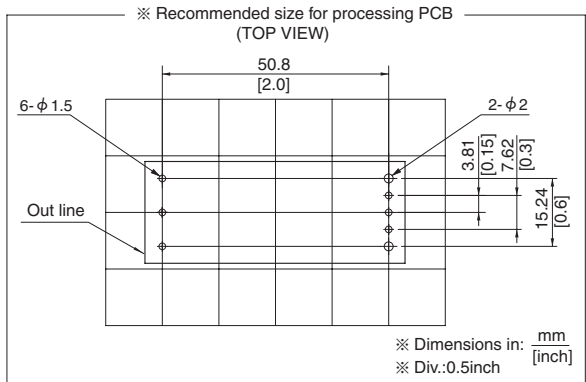
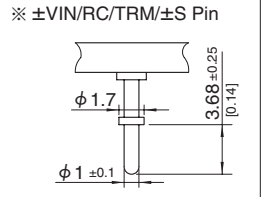
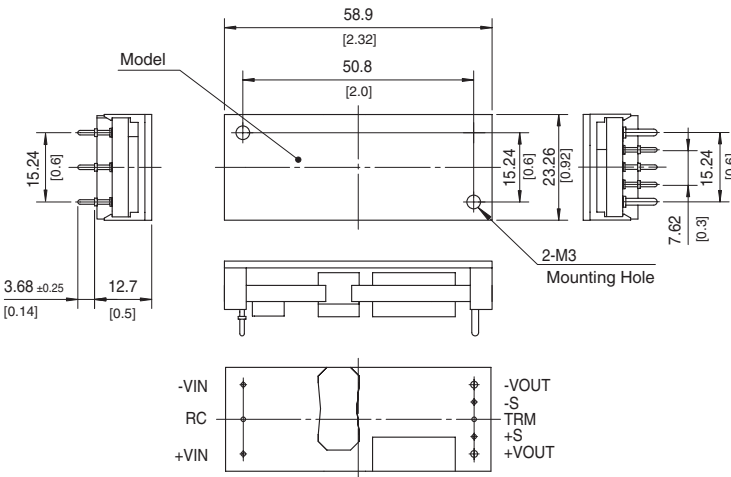

3. 5pins type (option L5)

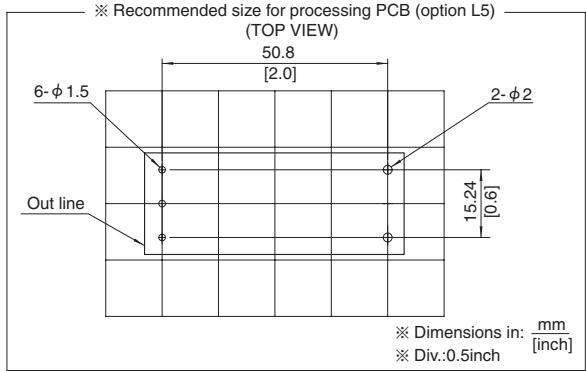
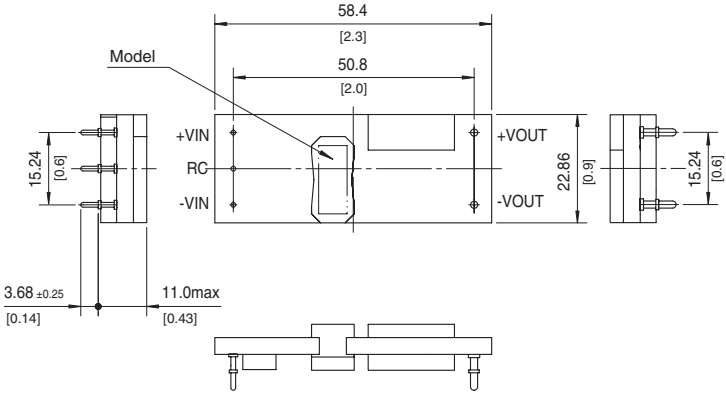

CHS400

CH S 400 48 12 - □

① ② ③ ④ ⑤ ⑥

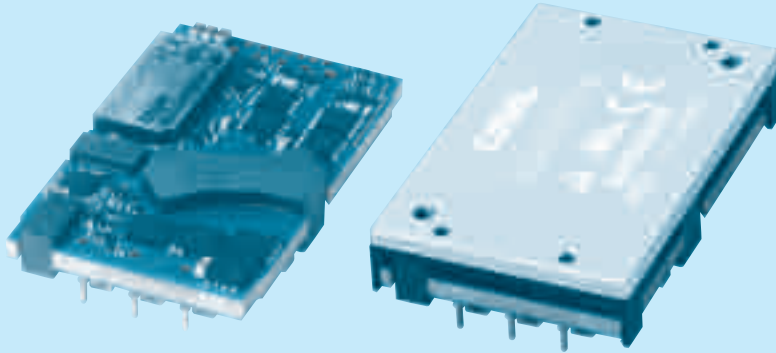
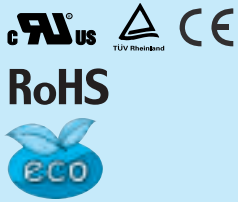

- ① Series name
- ② Single output
- ③ Output power
400:400W
- ④ Input voltage
48:DC36 - 76V
- ⑤ Output voltage
10:10V
12:12V
12H:12V(High efficiency type)
- ⑥ Optional
R :with Remote ON/OFF
Positive logic control
U :Shut down in protection
circuit working
B :BasePlate option with
Mounting hole M3
P :Parallel operation (5Pins
:without +S,-S and TRM)
L2:Pin length 5.3mm
L5:5pins type (+S,-S,TRM
less)

MODEL	CHS4004810	CHS4004812	CHS4004812H
MAX OUTPUT WATTAGE[W]	400.0	396.0	396.0
DC OUTPUT	10V 40A	12V 33A	12V 33A

SPECIFICATIONS

	MODEL	CHS4004810	CHS4004812	CHS4004812H	
INPUT	VOLTAGE[V]	DC36 - 76			
	CURRENT[A] *1	8.82typ	8.68typ	8.64typ	
	EFFICIENCY[%] *1	94.5typ	95typ	95.5typ	
OUTPUT	VOLTAGE[V]	10	12	12	
	CURRENT[A]	40	33	33	
	LINE REGULATION[mV] *7	±10max	±12max	±12max	
	LOAD REGULATION[mV] *6 *7	±10max	±12max	±12max	
	RIPPLE	[mVrms] *2	60max	60max	60max
		[mVp-p] *2	160max	180max	180max
	RIPPLE NOISE[mVp-p] *2	180max	200max	200max	
	TEMPERATURE REGULATION[mV]	200max	240max	240max	
	DRIFT[mV] *3	30max	40max	40max	
	START-UP TIME[ms]	50max (DCIN 48V, Io=100%)			
OUTPUT VOLTAGE ADJUSTMENT RANGE[V] *4	Fixed (TRM pin open), adjustable by external resistor (N/A : parallel operation)				
		-10% / +10%	-10% / +10%	-10% / +10%	
OUTPUT VOLTAGE SETTING[V] *1 *5	±1.6%	±1.6%	±1.6%		
PROTECTION CIRCUIT AND OTHERS	OVERCURRENT PROTECTION	Works over 105% of rating (Auto restart)			
	OVERVOLTAGE PROTECTION	115% - 135% (Auto restart)			
	REMOTE SENSING	Provided (N/A : parallel operation)			
	REMOTE ON/OFF	Provided (Negative Logic L : ON, H :OFF)			
ISOLATION	INPUT-OUTPUT	DC2,250V or AC1,000V 1minute, Cutoff current = 10mA, DC500V 50MΩ min (20±15°C)			
	INPUT-BASEPLATE *5	DC2,250V or AC1,000V 1minute, Cutoff current = 10mA, DC500V 50MΩ min (20±15°C)			
	OUTPUT-BASEPLATE *5	AC500V 1minute, Cutoff current = 10mA, DC500V 50MΩ min (20±15°C)			
ENVIRONMENT	OPERATING TEMP.,HUMID.AND ALTITUDE	-40 to +85°C, 20 - 95%RH (Non condensing) (Refer to DERATING CURVE), 5,000m (16,000 feet) max			
	STORAGE TEMP.,HUMID.AND ALTITUDE	-40 to +100°C, 20 - 95%RH (Non condensing), 9,000m (30,000 feet) max			
	VIBRATION	10 - 55Hz, 49.0m/s ² (5G), 3minutes period, 60minutes each along X, Y and Z axis			
	IMPACT	196.1m/s ² (20G), 11ms, once each along X, Y and Z axis			
SAFETY	AGENCY APPROVALS	UL60950-1, C-UL (CSA60950-1), EN60950			
OTHERS	CASE SIZE/WEIGHT	58.4×9.5×36.8mm [2.3×0.37×1.45 inches] (W×H×D) / 60g max			
	COOLING METHOD	58.9×12.7×37.3mm [2.32×0.5×1.47 inches] (W×H×D) / 90g max *5			
		Convection / Forced air / Conduction			

*1 At rated input (DC48V) and rated load. Ta=25°C, 2m/s.
 *2 Ripple and ripple noise is measured by using measuring board with ceramic capacitor 22 μF.
 *3 Drift is the change in DC output for an eight hour period after a half-hour warm-up at 25°C, with the input voltage held constant at the rated input/output.
 *4 Refer to the instruction manual for input voltage derating.
 *5 BasePlate Option.
 *6 Parallel operation Option is not included.
 *7 At input voltage DC36-76V(CHS4004810, CHS4004812), DC40-76V(CHS4004812H).

External view

1. DIP

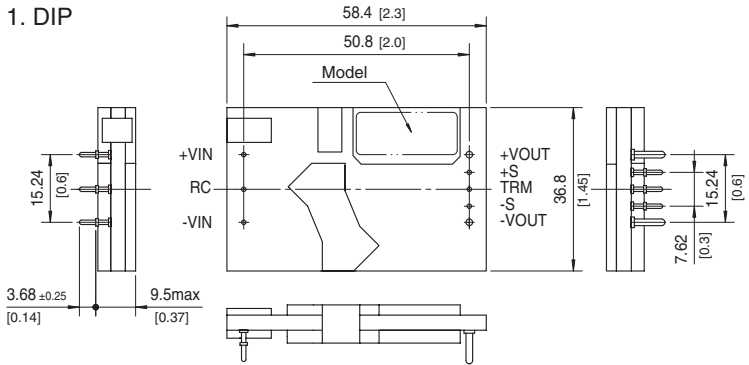

※ Tolerance:±0.5
※ Dimensions in mm, []=inches

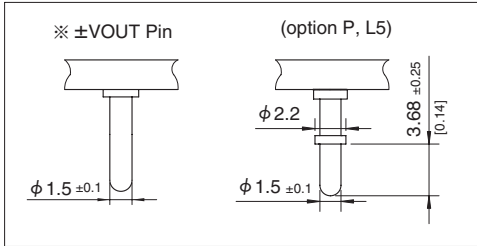

2. BasePlate (optionB)

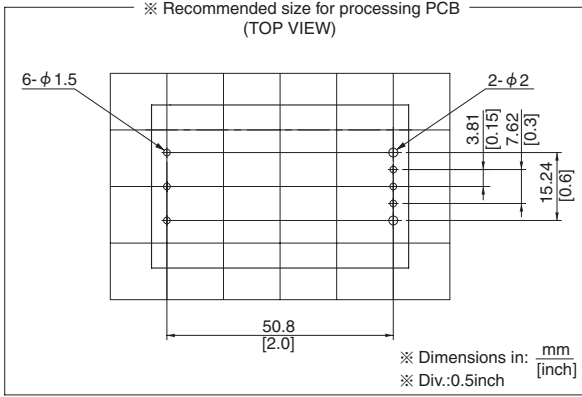
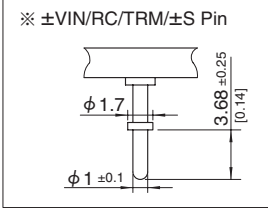
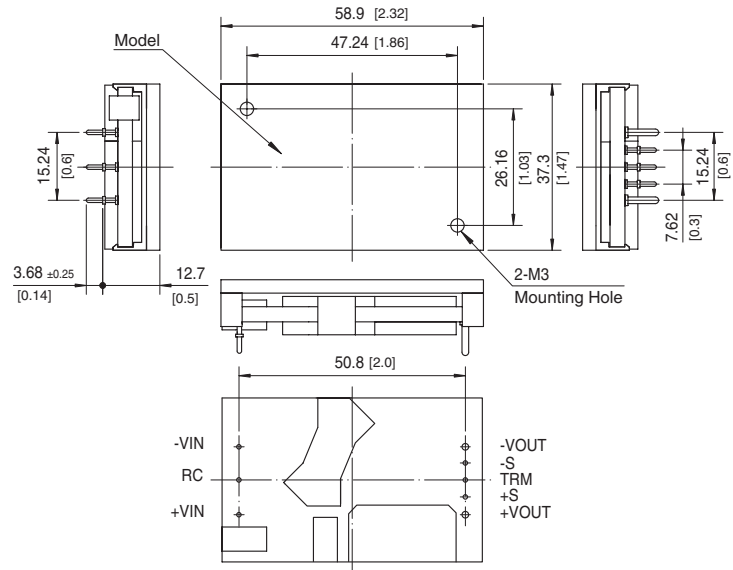

3. Parallel operation (option P)
5pins type (option L5)

