

3108NL (80[□] x 20^L)



EMINEBEA.COM

General Specifications

Motor Protection:

Auto Restart/Polarity Protection

Insulation Resistance: 10M Ω or over with a DC500V Megger

Dielectric Withstand Voltage: AC 700V 1s

Allowable Ambient Temperature Range:

-10°C ~ +70°C (Operating)

-40°C ~ +70°C (Storage)

(non-condensing environment)

Outline

Units: $\frac{\text{inch}}{\text{(mm)}}$

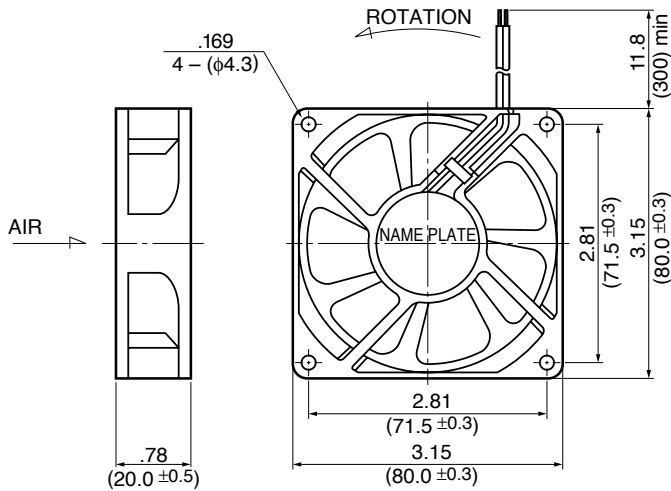

Characteristic Curves

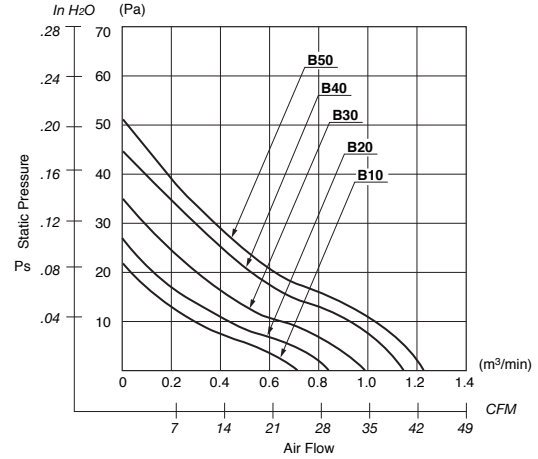

Panel Cut-outs

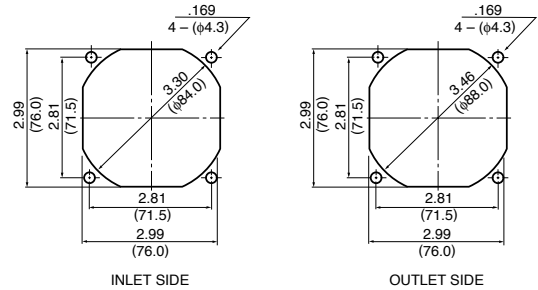

Material

Casing : Plastic (Black) 94V-0

Impeller : Plastic (Black) 94V-0

Bearing : Ball Bearing

Lead Wire: UL1007, AWG24, +Red, -Black

Specifications

MODEL	Product No.	Rated Voltage	Operating Voltage	Current	Input Power	Speed	Max. Air Flow		Max. Static Pressure		Noise	Mass
		(V)	(V)	(A) ^{*1}	(W) ^{*1}	(min ⁻¹) ^{*1}	CFM ^{*1}	(m ³ /min) ^{*1}	in H ₂ O	(Pa) ^{*1}	(dB) ^{*1}	(g)
3108NL-04W-B10-	X00	12	6.0 ~ 13.8	0.09	1.08	2350	26.5	0.75	.08	21.0	26.0	85
3108NL-04W-B20-	X00	12	6.0 ~ 13.8	0.11	1.32	2600	29.6	0.84	.10	26.0	29.0	85
3108NL-04W-B30-	X00	12	6.0 ~ 13.8	0.14	1.68	2950	34.6	0.98	.13	33.5	32.5	85
3108NL-04W-B40-	X00	12	6.0 ~ 13.8	0.20	2.40	3350	40.6	1.15	.17	43.7	38.5	85
3108NL-04W-B50-	X00	12	6.0 ~ 13.8	0.28	3.36	3750	44.0	1.25	.20	50.1	42.0	85
3108NL-05W-B10-	X00	24	15.0 ~ 27.6	0.05	1.30	2350	26.5	0.75	.08	21.0	26.0	85
3108NL-05W-B20-	X00	24	15.0 ~ 27.6	0.06	1.44	2600	29.6	0.84	.10	26.0	29.0	85
3108NL-05W-B30-	X00	24	15.0 ~ 27.6	0.07	1.68	2950	34.6	0.98	.13	33.5	32.5	85
3108NL-05W-B40-	X00	24	15.0 ~ 27.6	0.11	2.64	3350	40.6	1.15	.17	43.7	38.5	85
3108NL-05W-B50-	X00	24	15.0 ~ 27.6	0.15	3.60	3750	44.0	1.25	.20	50.1	42.0	85

Rotation: Counterclockwise

Airflow Outlet: Air Out Over Struts

*1: Average Values in Free Air