

## General Specifications

### Motor Protection:

Auto Restart/Polarity Protection

### Insulation Resistance:

10M Ω or over with a DC500V Megger

### Dielectric Withstand Voltage: AC 700V 1s

### Allowable Ambient Temperature Range:

-10°C ~ +70°C (Operating)

-40°C ~ +70°C (Storage)

(non-condensing environment)

## Expected Life

### Failure Rate: 10%

25°C 100,000 Hours (B00/E00)

## Material

Casing : Plastic (Black) 94V-0

Impeller : Plastic (Black) 94V-0

Bearing : Ball Bearing

Lead Wire : UL3385, AWG26, +Red, -Black

## Panel Cut-Outs

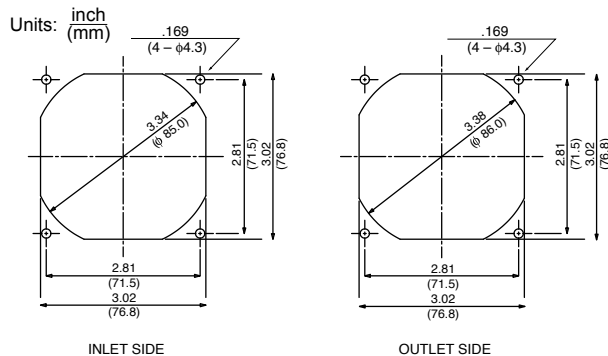

## Characteristic Curves

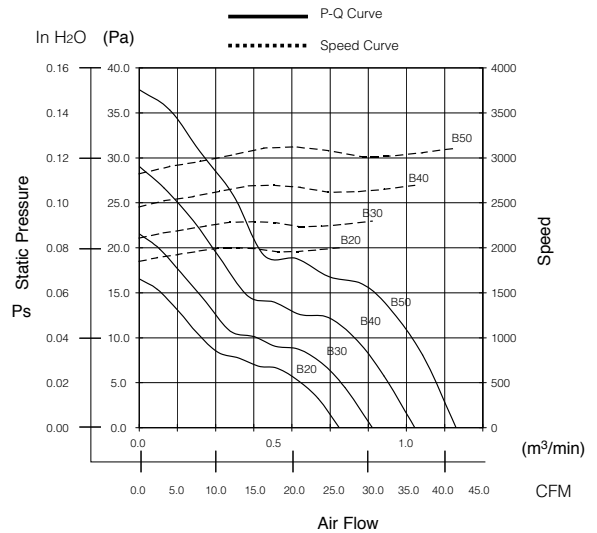

## Outline

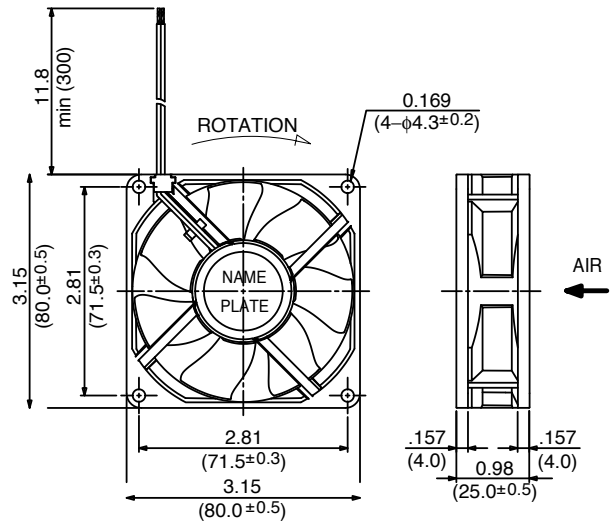

## Specifications

MODEL	Product No.	Rated Voltage	Operating Voltage	Current	Input Power	Speed	Max. Air Flow		Max. Static Pressure		Noise	Mass
		(V)	(V)	(A) <sup>*1</sup>	(W) <sup>*1</sup>	(min <sup>-1</sup> ) <sup>*1</sup>	CFM <sup>*1</sup>	(m <sup>3</sup> /min) <sup>*1</sup>	in H <sub>2</sub> O	(Pa) <sup>*1</sup>	(dB) <sup>*1</sup>	(g)
3110SB-04W-B20	B/EXX	12	6 ~ 13.8	0.05	0.60	2000	26.1	0.74	0.07	16.5	19.0	80
3110SB-04W-B30	B/EXX	12	6 ~ 13.8	0.06	0.72	2300	30.4	0.86	0.09	21.5	22.0	80
3110SB-04W-B40	B/EXX	12	6 ~ 13.8	0.09	1.08	2700	36.0	1.02	0.12	29.0	26.0	80
3110SB-04W-B50	B/EXX	12	6 ~ 13.8	0.14	1.68	3100	41.3	1.17	0.15	37.5	30.0	80
3110SB-05W-B20	B/EXX	24	12.0 ~ 27.6	0.03	0.72	2000	26.1	0.74	0.07	16.5	19.0	80
3110SB-05W-B30	B/EXX	24	12.0 ~ 27.6	0.04	0.96	2300	30.4	0.86	0.09	21.5	22.0	80
3110SB-05W-B40	B/EXX	24	12.0 ~ 27.6	0.06	1.44	2700	36.0	1.02	0.12	29.0	26.0	80
3110SB-05W-B50	B/EXX	24	12.0 ~ 27.6	0.08	1.92	3100	41.3	1.17	0.15	37.5	30.0	80

Rotation: Clockwise

Airflow Outlet: Air Out Over Struts

\*1: Average Values in Free Air