

General Specifications

Motor Protection:

Auto Restart/Polarity Protection

Insulation Resistance:

10M Ω or over with a DC500V Megger

Dielectric Withstand Voltage: AC 700V 1s

Allowable Ambient Temperature Range:

B50, B40 Class: -10°C ~ +45°C (Operating)

B30 Class: -10°C ~ +50°C (Operating)

All Class: -40°C ~ +60°C (Storage)

Expected Life

Failure Rate: 10%

25°C 100,000 Hours (R00)

Characteristic Curves

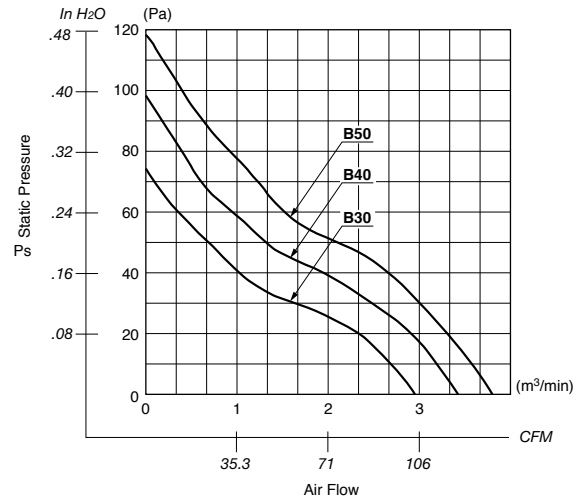

Material

Casing : Plastic (Black) 94V-0

Impeller : Plastic (Black) 94V-0

Bearing : Ball Bearing

Lead Wire : UL1007, AWG26, +Red, -Black

Outline

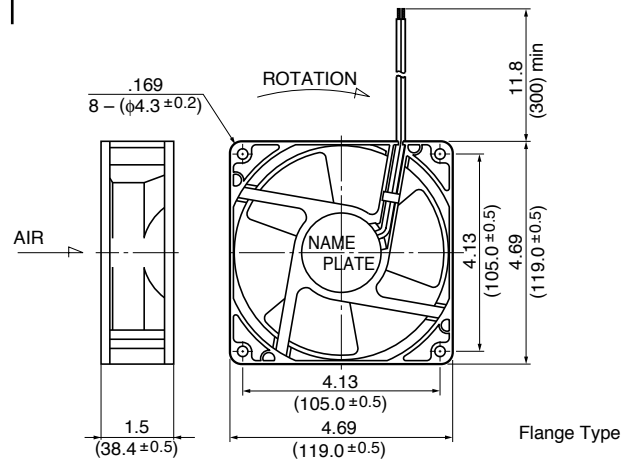

Panel Cut-Outs

Units: inch (mm)

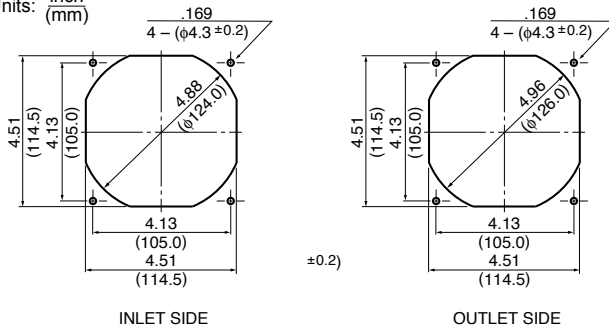

Specifications

MODEL	Product No.	Rated Voltage	Operating Voltage	Current	Input Power	Speed	Max. Air Flow		Max. Static Pressure		Noise	Mass
		(V)	(V)	(A) ^{*1}	(W) ^{*1}	(min ⁻¹) ^{*1}	CFM ^{*1}	(m ³ /min) ^{*1}	in H ₂ O	(Pa) ^{*1}	(dB) ^{*1}	(g)
4715KL-04W-B50-	R00	12	9.5 ~ 12.6	0.85	10.2	3900	132.0	3.73	.45	113.0	54.0	260
4715KL-05W-B50-	R00	24	20.0 ~ 25.0	0.48	11.5	3900	132.0	3.73	.45	113.0	54.0	260
** 4715KL-07W-B30-	R00	48	25.0 ~ 55.2	0.13	6.24	3100	105.0	2.97	.30	74.0	47.0	260
** 4715KL-07W-B40-	R00	48	25.0 ~ 50.4	0.16	7.68	3500	121.0	3.44	.39	97.5	51.0	260
** 4715KL-07W-B50-	R00	48	36.0 ~ 50.0	0.20	9.60	3900	132.0	3.73	.45	113.0	54.0	260

Rotation: Clockwise

Airflow Outlet: Air Out Over Struts

*1: Average Values in Free Air

** Contact NMB for availability