

FBA08A (80[□] x 25.5^L)



EMINEBEA.COM

THIS MODEL IS NO LONGER AVAILABLE FOR NEW DESIGNS
SEE OTHER MODELS AVAILABLE IN THIS FRAME SIZE HERE - 3110SB/3110KL

General Specifications

Allowable Ambient Temperature Range:

- 10°C ~ +70°C (65%RH) (Operating)
- 40°C ~ +75°C (65%RH) (Operating)
- (non-condensing environment)

Expected Life

Failure Rate: 10%
50,000 Hours (40°C, 65%RH)

Outline

Units: $\frac{\text{inch}}{\text{mm}}$

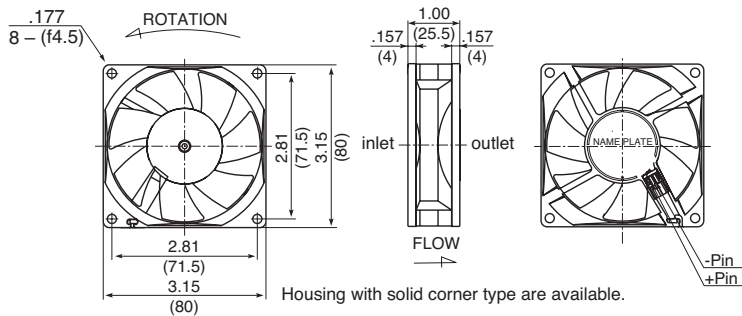

Characteristic Curves

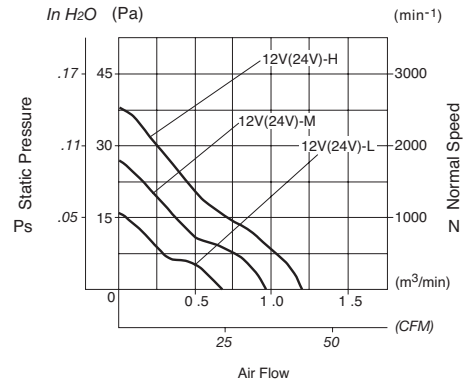

Panel Cut-outs

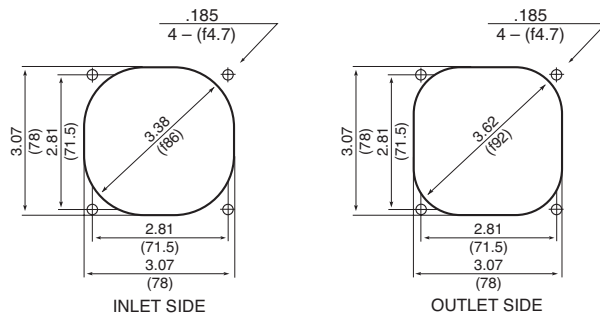

Material

Bearing: Hydro Wave Bearing

Specifications

MODEL	Rated Voltage	Operating Voltage	Current	Input Power	Rated Speed	Max. Air Flow		Max. Static Pressure		Noise	Mass
	(V)	(V)	(A) ^{*1}	(W) ^{*1}	(min ⁻¹) ^{*1}	CFM ^{*1}	(m ³ /min) ^{*1}	in H ₂ O	(Pa) ^{*1}	(dB) ^{*1}	(g)
FBA08A 12L	12	7.0 ~ 13.8	68	0.82	1900	24.0	0.68	.06	15.4	21.0	100
FBA08A12M	12	7.0 ~ 13.8	124	1.49	2450	32.1	0.91	.09	24.6	28.0	100
FBA08A 12H	12	7.0 ~ 13.8	173	2.08	2950	39.6	1.12	.14	37.1	32.0	100
FBA08A 24L	24	14.0 ~ 27.6	54	1.30	1900	24.0	0.68	.06	15.4	21.0	100
FBA08A 24M	24	14.0 ~ 27.6	71	1.70	2450	32.1	0.91	.09	24.6	28.0	100
FBA08A 24H	24	14.0 ~ 27.6	105	2.52	2950	39.6	1.12	.14	37.1	32.0	100

Rotation: Clockwise

Airflow Outlet: Air Out Over Struts

*1: Average Values in Free Air