

General Specifications

Motor Protection:

Auto Restart/Polarity Protection

Insulation Resistance:

10M Ω or over with a DC500V Megger

Dielectric Withstand Voltage: AC 700V 1s

Allowable Ambient Temperature Range:

-10°C ~ +70°C (Operating)

-40°C ~ +70°C (Storage)

(non-condensing environment)

Expected Life

Failure Rate: 10%

25°C 70,000 Hours (00)

Material

Casing : Plastic (Black) 94V-0

Impeller : Plastic (Black) 94V-0

Bearing : Ball Bearing

Lead Wire : UL1007, AWG26, +Red, -Black

Outline

Units: $\frac{\text{inch}}{\text{mm}}$

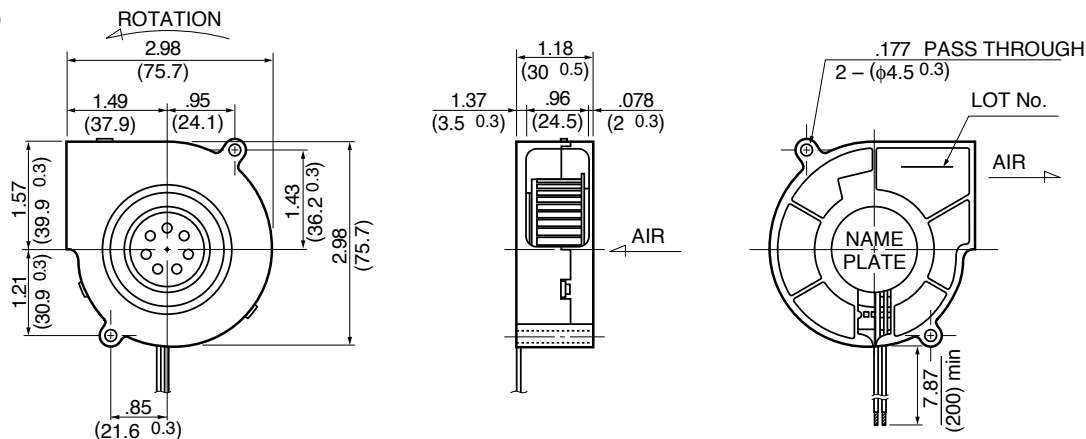

Specifications

MODEL	Product No.	Rated Voltage	Operating Voltage	Current	Input Power	Speed	Max. Air Flow		Max. Static Pressure		Noise	Mass
		(V)	(V)	(A) ^{*1}	(W) ^{*1}	(min ⁻¹) ^{*1}	CFM ^{*1}	(m ³ /min) ^{*1}	in H ₂ O	(Pa) ^{*1}	(dB) ^{*1}	(g)
BG0703-B041-000-	X0	12	6 ~ 13.8	0.10	1.20	2000	6.7	0.19	.16	40	28.0	90
BG0703-B042-000-	X0	12	6 ~ 13.8	0.12	1.44	2200	7.4	0.21	.20	50	29.5	90
BG0703-B043-000-	X0	12	6 ~ 13.8	0.18	2.16	2550	8.8	0.25	.30	75	34.5	90
BG0703-B044-000-	X0	12	6 ~ 13.0	0.29	3.48	3000	10.6	0.30	.44	110	38.5	90
BG0703-B051-000-	X0	24	10 ~ 27.6	0.06	1.44	2000	6.7	0.19	.16	40	28.0	90
BG0703-B052-000-	X0	24	10 ~ 27.6	0.07	1.68	2200	7.4	0.21	.20	50	29.5	90
BG0703-B053-000-	X0	24	10 ~ 27.6	0.09	2.16	2550	8.8	0.25	.30	75	34.5	90
BG0703-B054-000-	X0	24	10 ~ 26.0	0.15	3.60	3000	10.6	0.30	.44	110	38.5	90

Rotation: Counterclockwise

*1: Average Values in Free Air

Characteristic Curves

