

General Specifications

Motor Protection:

Auto Restart/Polarity Protection

Insulation Resistance:

10M Ω or over with a DC500V Megger

Dielectric Withstand Voltage: AC 700V 1s

Allowable Ambient Temperature Range:

-10°C ~ +60°C (Operating)

-40°C ~ +70°C (Storage)

(non-condensing environment)

Expected Life

Failure Rate: 10%

25°C 50,000 Hours (L00)

Material

Casing : Plastic (Black) 94V-0

Impeller : Plastic (Black) 94V-0

Bearing : Ball Bearing

Lead Wire : UL1061, AWG26, +Red, -Black

Outline

Units: $\frac{\text{inch}}{\text{(mm)}}$

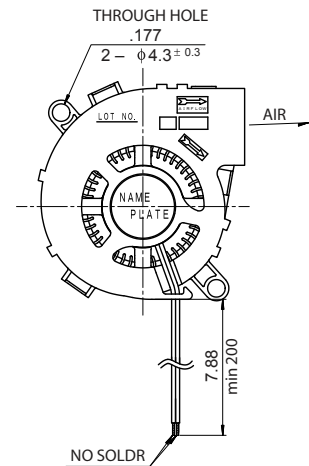
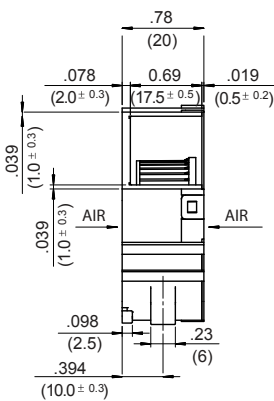
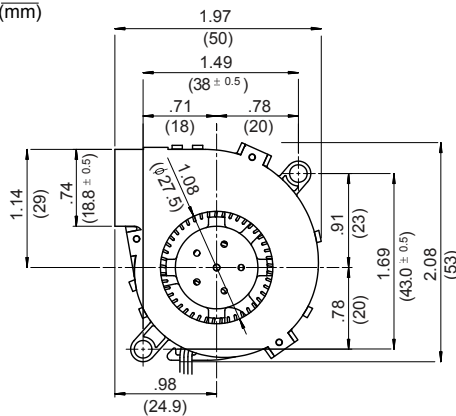

Specifications

MODEL	Product No.	Rated Voltage	Operating Voltage	Current	Input Power	Speed	Max. Air Flow		Max. Static Pressure		Noise	Mass
		(V)	(V)	(A) ^{*1}	(W) ^{*1}	(min ⁻¹) ^{*1}	CFM ^{*1}	(m ³ /min) ^{*1}	in H ₂ O	(Pa) ^{*1}	(dB) ^{*1}	(g)
BM5020-01W-B30-	L00	5	4.5 ~ 5.5	0.34	1.70	4600	4.6	0.13	.50	124	27.0	30
BM5020-04W-B20-	L00	12	4.5 ~ 13.8	0.07	0.84	3600	3.5	0.10	.30	75	20.0	30
BM5020-04W-B30-	L00	24	4.5 ~ 13.8	0.12	1.44	4600	4.6	0.13	.50	124	27.0	30
BM5020-04W-B40-	L00	24	4.5 ~ 13.8	0.18	2.16	5600	5.6	0.16	.74	184	32.0	30
BM5020-05W-B40-	L00	24	12.0 ~ 25.2	0.08	1.92	5600	5.6	0.16	.74	184	32.0	30

Rotation: Counterclockwise

*1: Average Values in Free Air

Characteristic Curves

