



General Specifications

Motor Protection:

Auto Restart/Polarity Protection

Insulation Resistance:

100M Ω or over with a DC500V Megger

Dielectric Withstand Voltage: AC 1800V 3s

Allowable Ambient Temperature Range:

-10°C ~ +70°C (Operating)

-40°C ~ +70°C (Storage)

(non-condensing environment)

Expected Life

Failure Rate: 10%

25°C 100,000 Hours

Outline

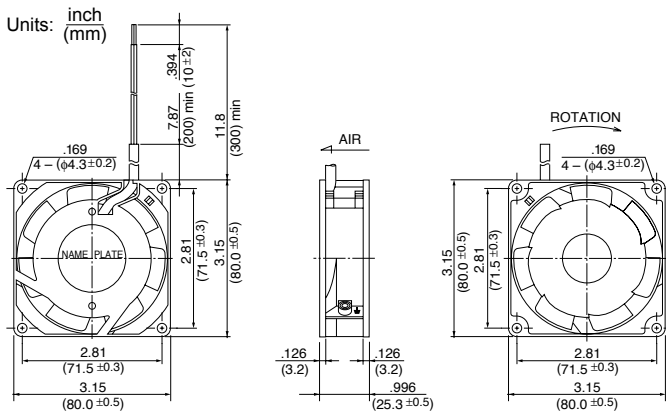

Characteristic Curves

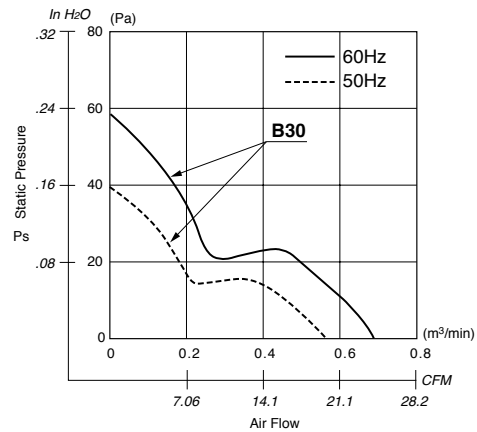

Panel Cut-outs

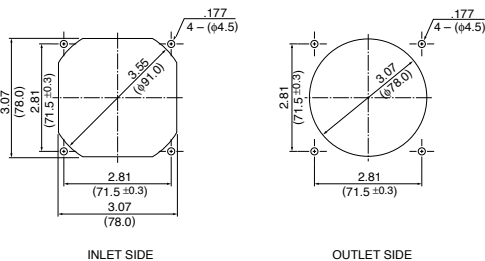

Material

Casing : Aluminum

Impeller : Polycarbonate (Glass Fiber-Containing)

Bearing : Ball Bearings

Lead Wire : UL3266, CSA CL1252, AWG22

Specifications

MODEL	Product No.	Rated Voltage	Frequency	Starting Voltage	Current	Input Power	Speed	Max. Air Flow		Max. Static Pressure		Noise	Mass
		(V)	(V)	(V)	(A) ^{*1}	(W) ^{+10% -20%}	(min ⁻¹) ^{*3}	CFM ^{*2}	(m ³ /min) ^{*2}	in H ₂ O ^{*2}	(Pa) ^{*2}	(dB) ^{*2}	(g)
3110MS-12W-B30-	A00	115	50	75	0.110	8.0	2500	20.1	0.57	0.15	39.0	24	240
3110MS-12W-B30-	A00	115	60	75	0.090	6.5	3000	24.0	0.68	0.22	55.0	31	240
3110MS-23W-B30-	A00	230	50	180	0.050	7.5	2500	20.1	0.57	0.15	39.0	24	240
3110MS-23W-B30-	A00	230	60	180	0.045	6.5	3000	24.0	0.68	0.22	55.0	31	240
** 3110MS-24W-B30-	A00	240	50	180	0.050	7.5	2500	20.1	0.57	0.15	39.0	24	240
** 3110MS-24W-B30-	A00	240	60	180	0.045	6.5	3000	24.0	0.68	0.22	55.0	31	240
** 3110MS-20W-B30-	B00	200	50	130	0.060	7.0	2500	20.1	0.57	0.15	39.0	24	240
** 3110MS-20W-B30-	B00	200	60	130	0.050	6.0	3000	24.0	0.68	0.22	55.0	31	240
** 3110MS-22W-B30-	B00	220	50	165	0.055	7.5	2500	20.1	0.57	0.15	39.0	24	240
** 3110MS-22W-B30-	B00	220	60	165	0.045	6.5	3000	24.0	0.68	0.22	55.0	31	240

Rotation: Counterclockwise

Airflow Outlet: Label Side

*1: Maximum Values in Free Air

*2: Average Values in Free Air

*3: Minimum Values in Free Air

** Not available in the the U.S.