



- ▶ LVDS
- ▶ 7 x 5 mm Footprint
- ▶ Low Jitter
- ▶ Pb Free/RoHS Compliant

ECS-LVDS25/LVDS33 SMD LVDS OSCILLATOR

ECS-LVDS25 (2.5V) and ECS-LVDS33 (3.3V) Low Voltage Differential Signaling SMD LVDS oscillators.

OPERATING CONDITIONS / ELECTRICAL CHARACTERISTICS

PARAMETERS	CONDITIONS	ECS-LVDS25 (+2.5V)			ECS-LVDS33 (+3.3V)			UNITS
		MIN	TYP	MAX	MIN	TYP	MAX	
Frequency Range		80.0		300.0	80.0		300.0	MHz
Operating Temperature	Standard	0		+70	0		+70	°C
	Extended (N Option)	-40		+85	-40		+85	°C
Storage Temperature		-50		+125	-50		+125	°C
Supply Voltage	VDD	+2.375	+2.5	+2.625	+3.135	+3.3	+3.465	VDC
Frequency Stability *	Option A			± 100			± 100	ppm
	Option B			± 50			± 50	ppm
	Option C			± 25			± 25	ppm
Input Current	Pin 1 open or VIH			70			70	mA
Stand-by Current	Pin 1 = VIL			30			30	µA
Output Symmetry	at Crossing point			45/55			45/55	%
Rise and Fall Times	20% VDD to 80% level			1			1	ns
"0" level	VOL		+1.10			+1.10		V
"1" level	VOH		+1.43			+1.43		V
Output Load	100Ω (Out-Outn)							
Differential output voltage			0.33			0.33		V
Offset voltage			1.25			1.25		V
Disable delay time				200			200	ns
Enable/Startup time				10			10	ms
RMS Jitter	12 KHz to 20 MHz band			1			1	ps
Aging (first year)	at +25°C ±3°C			± 5			± 5	ppm

DIMENSIONS (mm)

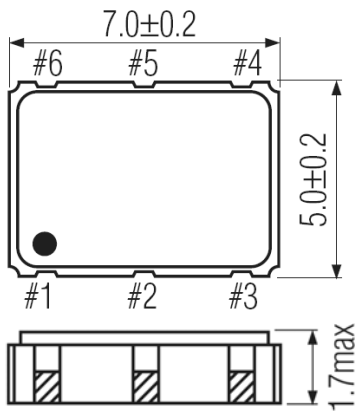

Figure 1) Top, Side and Bottom views

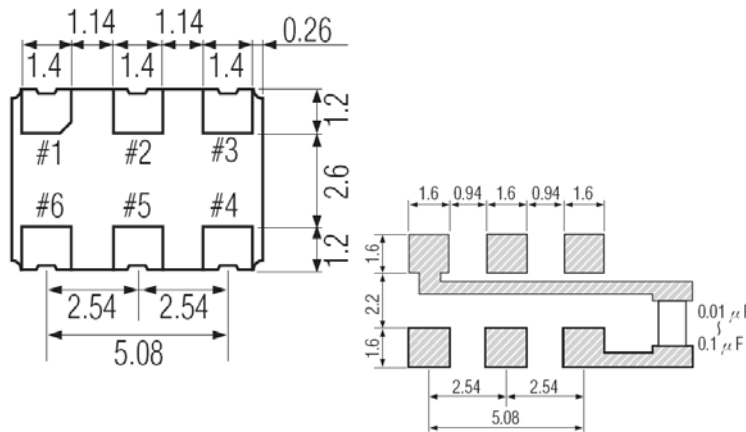

Figure 2) Suggested Land Pattern

Pin Connections	
Pin #1	Tri-State
Pin #2	N.C.
Pin #3	Ground
Pin #4	Output
Pin #5	C-Output
Pin #6	VDD

Tri-State Control Voltage	
Pad 1	Pad 4 & 5
Open	Oscillation
VIH 70% VDD Min	Oscillation
VIL 30% VDD Max	No Oscillation

Note: Internal crystal oscillation to be halted (Pin #1=VIL)

PART NUMBERING GUIDE: Example ECS-LVDS25-1000-A

ECS - Series - Frequency Abbreviation - Stability - Temperature

LVDS25 = +2.5V
LVDS33 = +3.3V

1000 = 100.000 MHz
See Frequency Abbreviations (Pg 2)

A = ± 100 ppm
B = ± 50 ppm
C = ± 25 ppm

Blank = 0 ~ +70°C
M = -20 ~ +70°C
N = -40 ~ +85°C

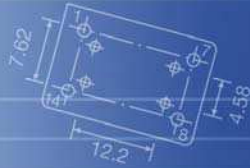

Frequency Abbreviations

FREQUENCY MHz	CODE
100.000	1000
106.250	1062.5
125.000	1250
156.250	1562.5
200.000	2000

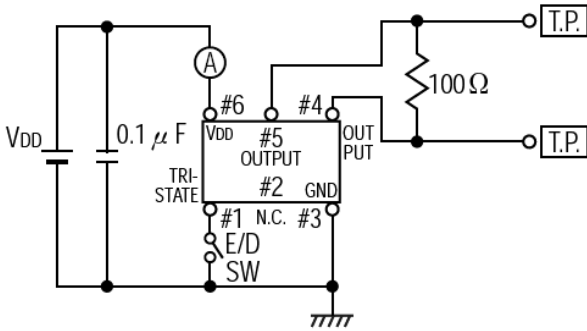

Figure 1) Test Circuit

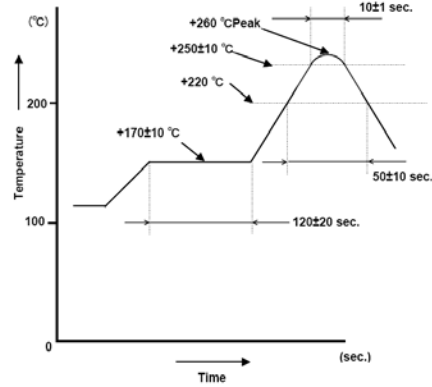

Figure 3) Suggested Reflow Profile

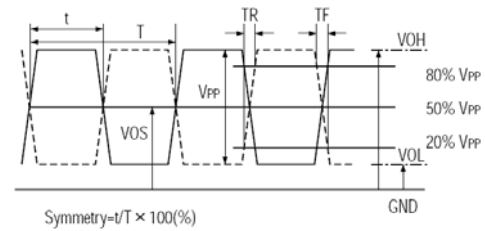
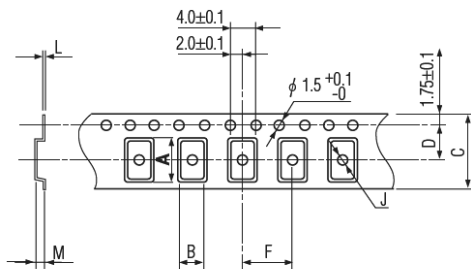

Figure 4) Output Waveform

TAPE DIMENSIONS (mm)



A	B	C	D	F	J	L	M	Reel Dia.	Qty/Reel
7.5	5.5	16.0	7.5	8.0	2.0	0.3	2.2	245	1000pcs

Figure 2) Pocket Tape Dimensions

Package Data	
Item	Description
Lid	Metal
Base	Ceramic
Sealing	Seam
Terminal	Tungsten (metallized)
Plating	Gold/Nickel (Surface)/(Under)
RoHS	Compliant (Pb Free)