

ECS-3951M/3953M SERIES SMD CLOCK OSCILLATOR

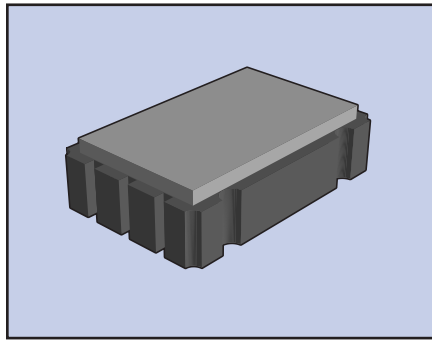

The ECS-3951M (5V) and ECS-3953M (3.3V) Series are miniature, crystal controlled, low current clock oscillators in a ceramic SMD package. Package is seam welded with a metal lid. The low profile package is ideal for today's advanced portable PC and instrumentation designs.

FEATURES

- 3.3 or 5.0V version
- Low power consumption
- Standby function
- Seam welded package
- Tape & Reel (1,000 pcs)
- PbFree/RoHS Compliant



PART NUMBERING GUIDE

PACKAGE TYPE	FREQUENCY (50.0 MHz)	STABILITY TOLERANCE (±50 PPM)
ECS-3951M	- 500	- B

Sample Part Number: ECS-3951M-500-B

OPERATING CONDITIONS/ELECTRICAL CHARACTERISTICS

PARAMETERS	CONDITIONS	ECS-3951M (5V)			ECS-3953M (3.3V)*			UNITS
		MIN	TYP	MAX	MIN	TYP	MAX	
FREQUENCY RANGE		1.800		125.0	1.800		125.00	MHz
TEMPERATURE RANGE	Operating	-10		+70	-10		+70	°C
	Storage	-55		+125	-55		+125	°C
SUPPLY VOLTAGE		+4.5	+5.0	+5.5	+3.0	+3.3	+3.6	V DC
FREQUENCY STABILITY**	Standard	-100	±40	+100	-100	±40	+100	PPM
	Option (B)	-50		+50	-50		+50	PPM
	Option (C)	-25		+25	-25		+25	PPM
INPUT CURRENT	1.8 ~ 36.0 MHz			20			15	mA
	36.0 ~ 70.0 MHz			55			25	mA
	70.0 ~ 100.0 MHz			60			30	mA
	100.0 ~ 125.0 MHz			65			30	mA
OUTPUT SYMMETRY	@ 1/2 Vcc Level	40/60	50 ±4	60/40	40/60	50 ±4	60/40	%
RISE AND FALL TIMES	1.8 ~ 70.0 MHz			15			5	nS
	70.0 ~ 125.0 MHz			5			5	nS
LOGIC "0" LEVEL	Vcc x 0.1V max.							
LOGIC "1" LEVEL	Vcc x 0.9V min.							
LOAD	HCMOS			30			15	pF
START-UP TIME	1.8 ~ 36.0 MHz			5			5	ms
	36.0 ~ 70.0 MHz			10			10	ms
	70.0 ~ 100.0 MHz			15			15	ms
OUTPUT CURRENT (IOL) (IOH)	VOL=0.5V/0.33			4			4	mA
	VOL=4.5V/2.97V			-4			-4	mA
ENABLE/DISABLE TIME				100			100	ns

* ECS-3953M is also compatible with a supply voltage of +3.0V DC ±0.3V

** Inclusive of 25°C tolerance, operating temperature range, input voltage change, load change, aging shock and vibration.

*** An internal pullup resistor from pin 1 to 4 allows active output if pin 1 is left open.

Note: A 0.01 µF bypass capacitor should be placed between VCC (Pin 4) and GND (Pin 2) to minimize power line noise.

PACKAGE DIMENSIONS (mm)

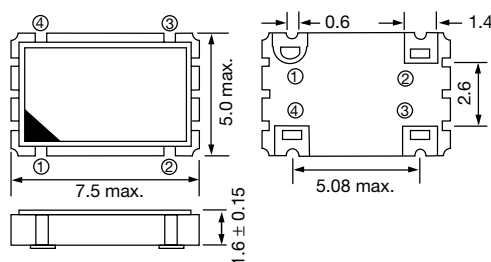

Figure 1) ECS-3951M/3953M Top, Side and Bottom views

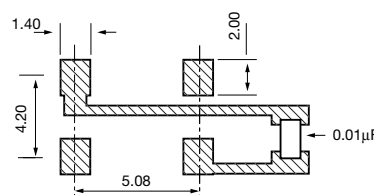

Figure 2) Land Pattern

PIN CONNECTIONS	
#1	TRI-STATE***
#2	GND
#3	OUTPUT
#4	VCC

ECS-3951M/3953M Standby Control Voltage	
PIN #1 = OPEN***	#3 = OSCILLATION
PIN #1 = +2.2V MIN	#3 = OSCILLATION
PIN #1 = 0.8V MAX	#3 = HIGH IMPEDANCE