

Specifications:

Military Unit

| | |
|-------------------------|-----------------------------------|
| Sound level Category | Medium Sound Level |
| Mode of Operation | High Frequency - Continuous |
| Mounting | Panel (see note B) |
| Voltage Rating | 6 to 28 Vac/dc |
| Frequency | 4500 Hz ±500 Hz |
| Loudness (Min. Voltage) | 68 dB(A) min. @ 2 FT and 6 Vac/dc |
| Loudness (Max Voltage) | 80 dB(A) min. @ 2FT and 28 Vac/dc |
| Current Draw | 4 mA Max @ 6 Vac/dc |
| Current Draw | 16 mA Max @ 28 Vac/dc |
| Storage Temperature | -65°C to +85°C |
| Operating Temperature | -40°C to +85°C |
| Weight (Typical) | 2.1 oz (59 g) |
| Housing | 6/6 Nylon, Color Black |
| Options | For other options contact factory |

Dimensions: Inches (mm)

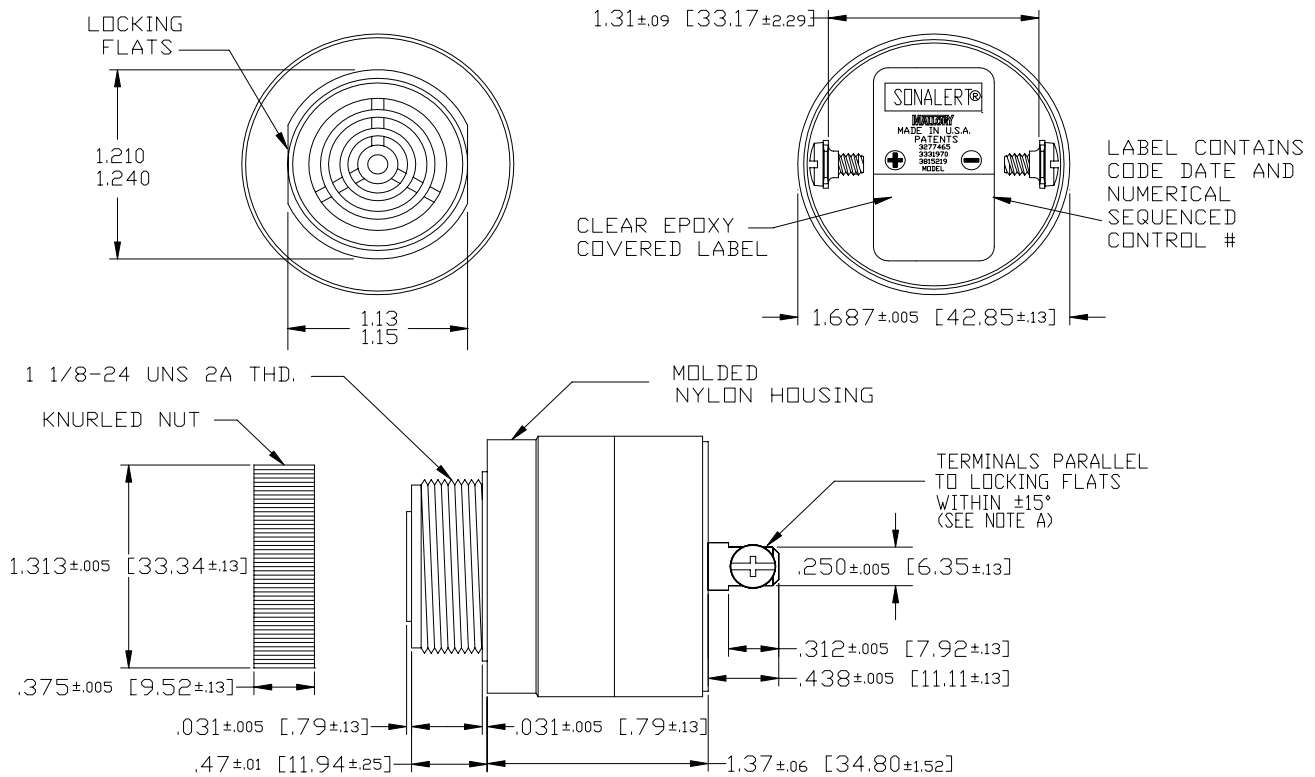

NOTE A: TERMINALS-.032 BRASS TIN PLATED, TAPPED FOR #6-32 SCREW. TWO #6-32 NICKEL PLATED BRASS SCREWS INCLUDED. WILL ACCEPT 1/4" QUICK CONNECT.

NOTE B: MOUNTING- REMOVE KNURLED NUT AND INSERT THREADED FRONT THROUGH 1.25" HOLE PUNCHED IN PANEL, IF ORIENTATION IS NEEDED, NOTE LOCKING FLATS ON DRAWING. SCREW NUT BACK ON. DO NOT OVERTIGHTEN.