

Specifications:

Military Unit

Sound level Category	Medium Sound Level
Mode of Operation	Fast Warble
Mounting	Panel (see note B)
Voltage Rating	6 to 28 Vdc
Frequency	2900 Hz ±500 Hz
Loudness (Min. Voltage)	70 dB(A) min. @ 2 FT and 6 Vdc
Loudness (Max Voltage)	85 dB(A) min. @ 2FT and 28 Vdc
Current Draw	4 mA Max @ 6 Vdc
Current Draw	16 mA Max @ 28 Vdc
Min Pulse Rate (PPS)	2 @ 6 Vdc
Max Pulse Rate (PPS)	10 @ 16 Vdc
Duty Cycle (%)	50 (Approx)
Storage Temperature	-65°C to +85°C
Operating Temperature	-40°C to +85°C
Weight (Typical)	2.3 oz (65 g)
Housing	6/6 Nylon, Color Black
Options	For other options contact factory

Dimensions: Inches (mm)

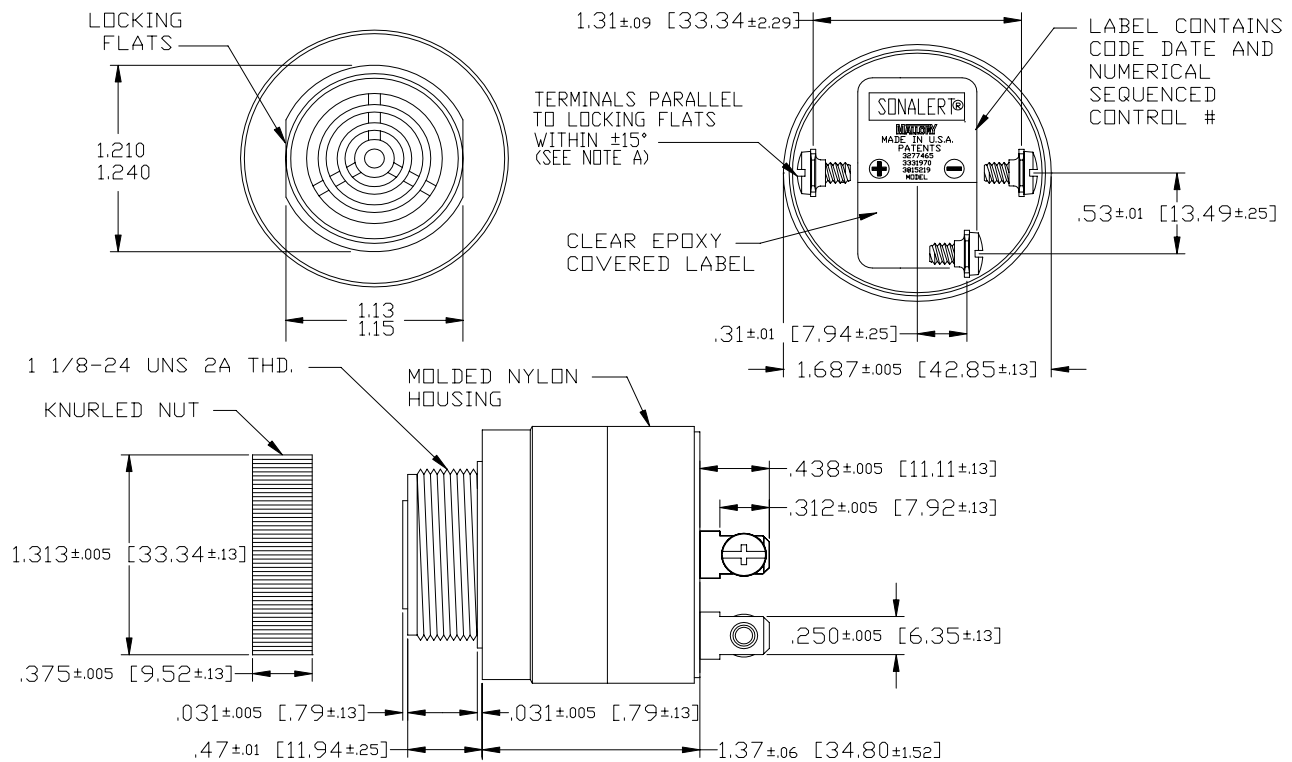

NOTE A: TERMINALS-.032 BRASS TIN PLATED, TAPPED FOR #6-32 SCREW. TWO #6-32 NICKEL PLATED BRASS SCREWS INCLUDED. WILL ACCEPT 1/4" QUICK CONNECT.

NOTE B: MOUNTING- REMOVE KNURLED NUT AND INSERT THREADED FRONT THROUGH 1.25" HOLE PUNCHED IN PANEL, IF ORIENTATION IS NEEDED, NOTE LOCKING FLATS ON DRAWING. SCREW NUT BACK ON. DO NOT OVERTIGHTEN.

PRODUCES TWO TONES ALTERNATELY WHEN USED WITH ADDITIONAL CONTINUOUS UNIT