

PNI CONNECTOR

2.0mm pitch/Crimp style wire-to-wire connectors

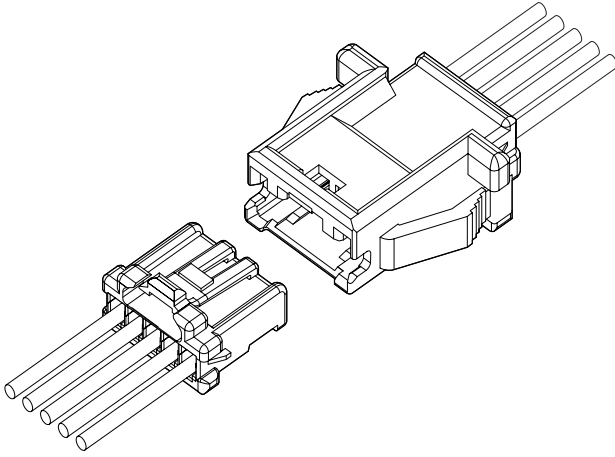

This connector is a 2.0mm pitch wire-to-wire connector, having incomplete mating prevention mechanism.

- Inertial lock structure
- Finger-friendly design
- Secure locking structure
- Mountable on a variety of panels
- Secondary retainer

Specifications

- Current rating: 3A AC, DC (AWG #22)
- Voltage rating: 100V AC, DC
- Temperature range: -25°C to +85°C
(including temperature rise in applying electrical current)
- Contact resistance: Initial value/ 15mΩ max.
After environmental testing/ 25mΩ max.
- Insulation resistance: 1,000MΩ min.
- Withstanding voltage: 800V AC/minute
- Applicable wire: AWG #28 to #22
- Applicable panel thickness: 0.5 to 2.0mm

- * Compliant with RoHS.
- * Refer to "General Instruction and Notice when using Terminals and Connectors" at the end of this catalog.
- * Contact JST for details.

Standards

Recognized E60389

Certified LR20812

Without panel locks



With panel locks

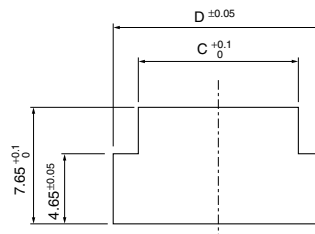
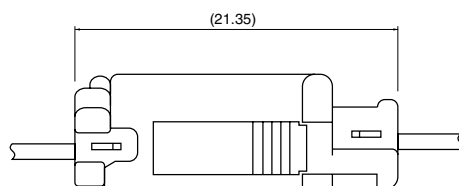

Note: C and D dimensions: Refer to receptacle housing.

Contact

Pin contact

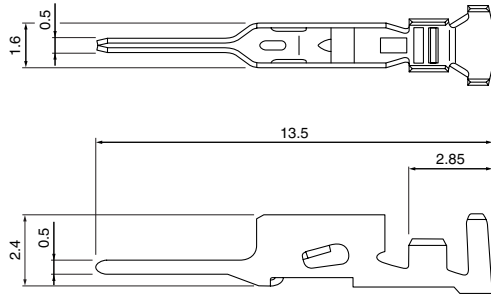

Socket contact

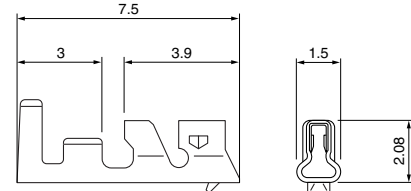

Pin contact

Model No.	Applicable wire		Insulation O.D. (mm)	Q'ty / reel
	mm ²	AWG#		
SPNI-001T-P0.5	0.13~0.33	26~22	1.0~1.5	9,000
SPNI-002T-P0.5	0.08~0.21	28~24	0.9~1.5	9,000

Material and Finish

Copper alloy, tin-plated (reflow treatment)

RoHS compliance

Contact	Crimping machine	Applicator		
		Crimp applicator	Dies	Crimp applicator with dies
SPNI-001T-P0.5	AP-K2N	MKS-L	MK/SPAL-001-05	APLMK SPAL001-05
SPNI-002T-P0.5		MKS-LS·MKS-L	MK/SPAL-002-05	APLMK SPAL002-05

Socket contact

Model No.	Applicable wire		Insulation O.D. (mm)	Q'ty / reel
	mm ²	AWG#		
SPND-001T-C0.5	0.13~0.33	26~22	1.0~1.5	8,000
SPND-002T-C0.5	0.08~0.22	28~24	0.8~1.5	8,000

Material and Finish

Copper alloy, tin-plated (reflow treatment)

RoHS compliance

Contact	Crimping machine	Applicator		
		Crimp applicator	Dies	Crimp applicator with dies
SPND-001T-C0.5	AP-K2N	MKS-L	MK/SPND-001-05	APLMK SPND001-05
SPND-002T-C0.5		MKS-LS·MKS-L	MK/SPAD/ND-002-05	APLMK SPAD/ND002-05

Receptacle housing (for pin contact)

Without panel locks

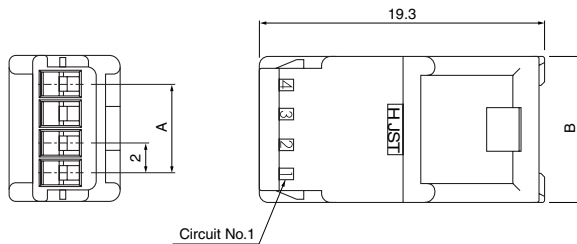

With panel locks

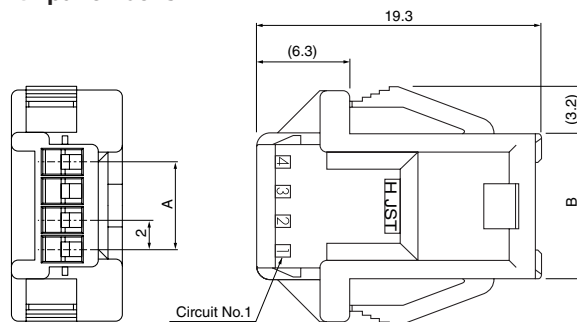

Circuits	Model No.		Dimensions (mm)				Q'ty / bag
	Without panel locks	With panel locks	A	B	C	D	
2	PNIRR-02VF	PNIRR-02V	-	6.0	6.4	9.7	1,000
3	PNIRR-03VF	PNIRR-03V	4.0	8.0	8.4	11.7	1,000
4	PNIRR-04VF	PNIRR-04V	6.0	10.0	10.4	13.7	500
5	PNIRR-05VF	PNIRR-05V	8.0	12.0	12.4	15.7	500
6	PNIRR-06VF	PNIRR-06V	10.0	14.0	14.4	17.7	500
8	PNIRR-08VF	PNIRR-08V	14.0	18.0	18.4	21.7	500
10	PNIRR-10VF	PNIRR-10V	18.0	22.0	22.4	25.7	500

Material

PA 66, UL94V-0, natural (white)

RoHS compliance

Note: C and D dimensions: Panel layout dimensions

PNI CONNECTOR

Socket housing (for socket contact)

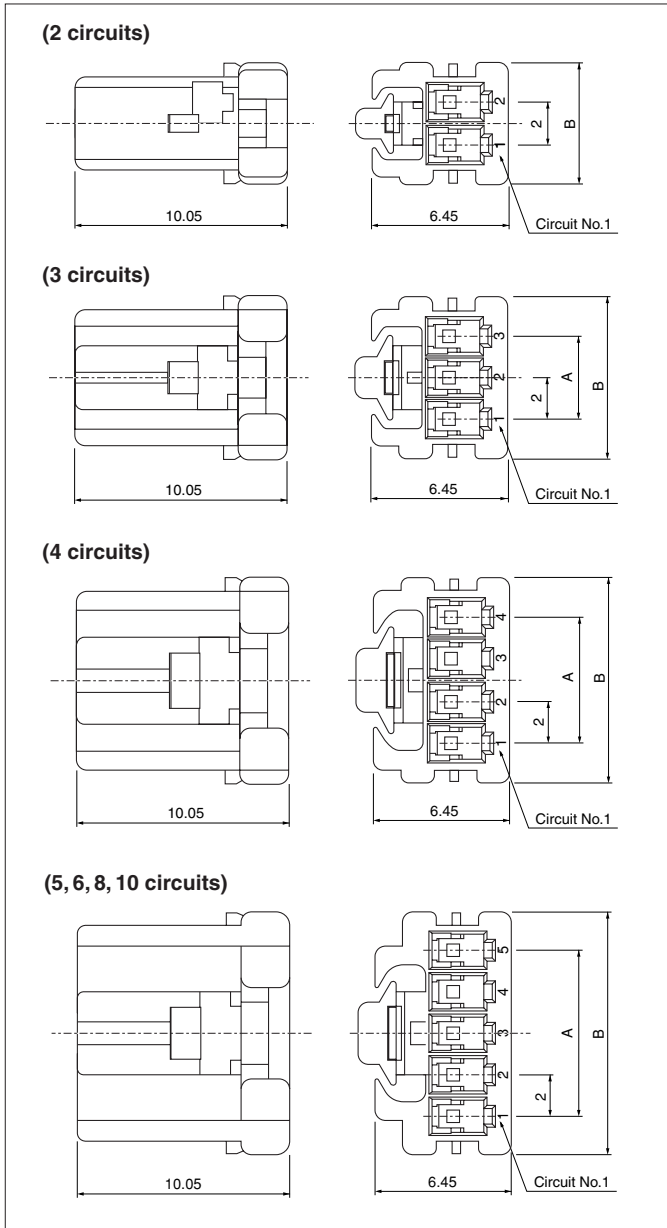

Circuits	Model No.	Dimensions (mm)		Q'ty / bag
		A	B	
2	PNIRP-02V-S	–	5.7	1,000
3	PNIRP-03V-S	4.0	7.7	1,000
4	PNIRP-04V-S	6.0	9.7	1,000
5	PNIRP-05V-S	8.0	11.7	1,000
6	PNIRP-06V-S	10.0	13.7	1,000
8	PNIRP-08V-S	14.0	17.7	1,000
10	PNIRP-10V-S	18.0	21.7	1,000

Material

Glass-filled PBT, UL94V-0, natural (white)

RoHS compliance

Retainer

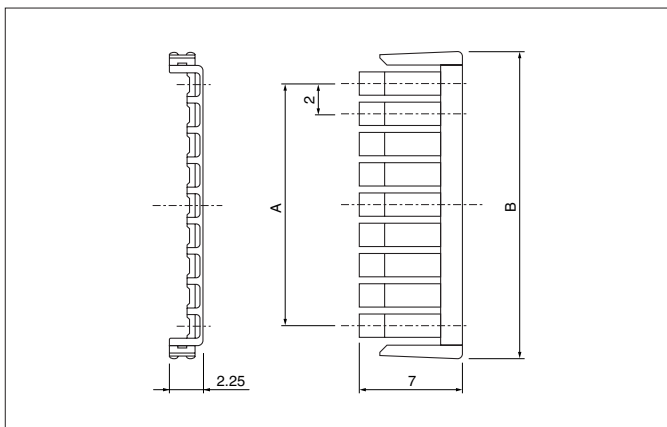

Circuits	Model No.	Dimensions (mm)		Q'ty / bag
		A	B	
2	PNIS-02V	–	6.3	1,000
3	PNIS-03V	4.0	8.3	1,000
4	PNIS-04V	6.0	10.3	1,000
5	PNIS-05V	8.0	12.3	1,000
6	PNIS-06V	10.0	14.3	1,000
8	PNIS-08V	14.0	18.3	1,000
10	PNIS-10V	18.0	22.3	1,000

Material

Glass-filled PA 66, UL94V-0, natural (ivory)

RoHS compliance