

REV.	DESCRIPTION/ECO NO.	DATE
	ENGR. RELEASE TO CAD	7/18/06

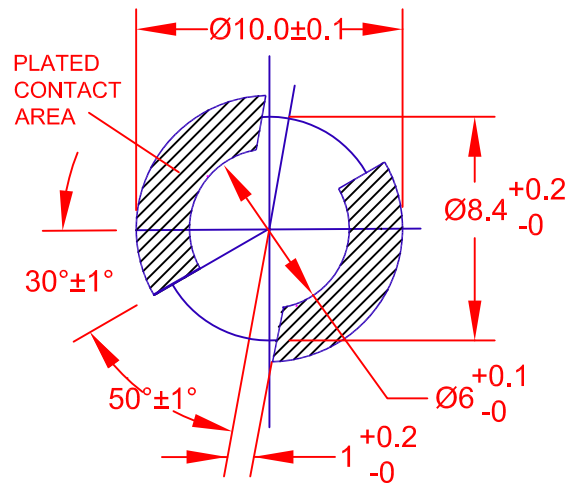

PC BOARD PUNCH PATTERN
(NO TREATMENT, SUCH AS APPLICATION OF FLUX, SHALL BE DONE.)

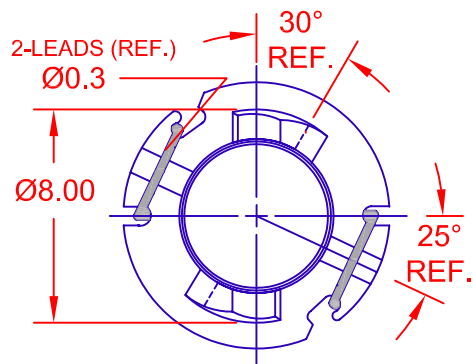
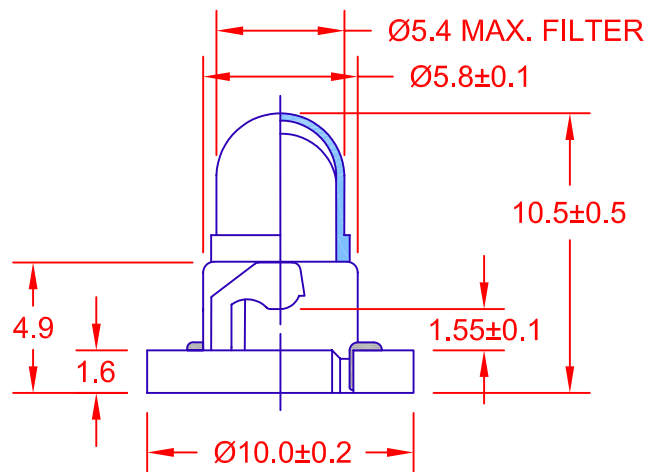

JKL PART NUMBER: DNW1-DW07/WHI11MM/39226B

LAMP NUMBER: DW07/9MM

VOLTS RATED	AMPS ± 10%	*MSCP ± 25%	*LUMENS ± 25%	AVERAGE LIFE HRS.	FILAMENT TYPE
14.0	.080	.300	3.77	15,000	C-2V

* LAMP RATING ONLY WITHOUT BASE AND FILTER.

FILTER NUMBER: 39-22-6B

BASE NUMBER: DNW1/WHI/5MM
BASE COLOR: WHITE

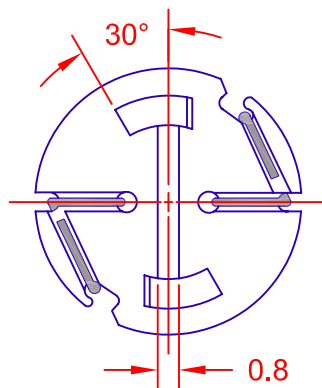

METRIC THIRD ANGLE PROJECTION	DIMENSIONS ARE IN MILLIMETERS TOLERANCE UNLESS OTHERWISE SPECIFIED 1 PL +/- 0.2 2 PL +/- 0.20 ANGLE +/- 0	JKL COMPONENTS CORPORATION			
	TITLE T-1 1/4 NEO-WEDGE BASE WITH DW07 LAMP AND 39-22-6B FILTER				
DRAWN BY L. WENGSTROM	APP'VD BY J.K.	DATE 7/18/06	SIZE A	FSCM NO. 55335	DRAWING NO. DNW1-DW07/WHI11MM/39226B
- CAD DRAWING - MANUAL REVISIONS NOT PERMITTED			SCALE NONE	RELEASED DATE 7/18/06	REVISION DATE REV. NO. SHEET 1 OF 1