

REV.	DESCRIPTION/ECO NO.	DATE
	RELEASED TO CAD	7/7/06

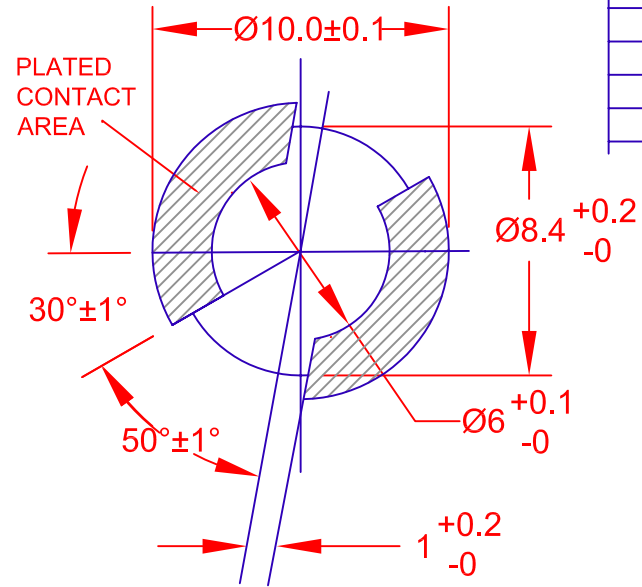

PC BOARD PUNCH PATTERN

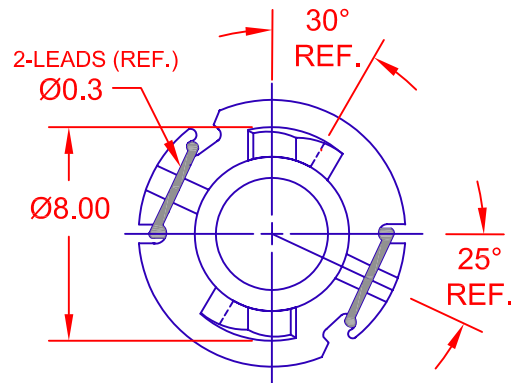
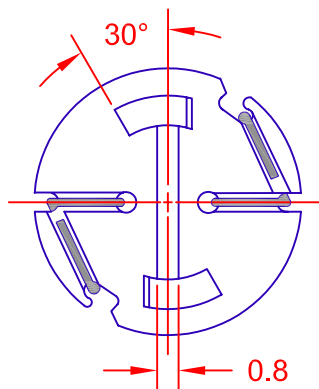
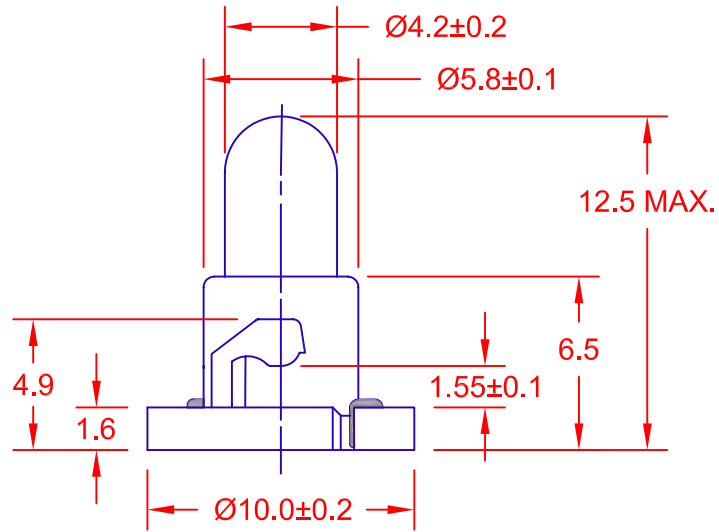

JKL PART NUMBER: DNW1-DW10/12.5MM/BLA

LAMP NUMBER: DW10

VOLTS RATED	AMPS $\pm 10\%$	*MSCP $\pm 25\%$	*LUMENS $\pm 25\%$	AVERAGE LIFE HRS.	FILAMENT TYPE
14.0	.100	.500	6.29	10,000	C-2F

*LAMP RATING ONLY WITHOUT BASE AND FILTER.

BASE COLOR: BLACK

METRIC		DIMENSIONS ARE IN MILLIMETERS		JKL COMPONENTS CORPORATION			
 THIRD ANGLE PROJECTION		TOLERANCE UNLESS OTHERWISE SPECIFIED 1 PL +/- 0.2 2 PL +/- 0 ANGLE +/- 0		TITLE			
				T-1 1/4 NEO-WEDGE BASE WITH DW10 LAMP			
DRAWN BY L. WENGSTROM	APPV'D BY E.D.	DATE 7/7/06	SIZE A	FSCM NO. 55335	DRAWING NO. DNW1-DW10/12.5MM/BLA		
- CAD DRAWING - MANUAL REVISIONS NOT PERMITTED			SCALE NONE	RELEASED DATE 7/7/06	REVISION DATE	REV. NO.	SHEET 1 OF 1