

REV.	DESCRIPTION/ECO NO.	DATE
	RELEASED CONVERTED TO CAD	10/16/00
A	DIM. & LIFE CHNG, ADD PCB NOTE	10/23/01

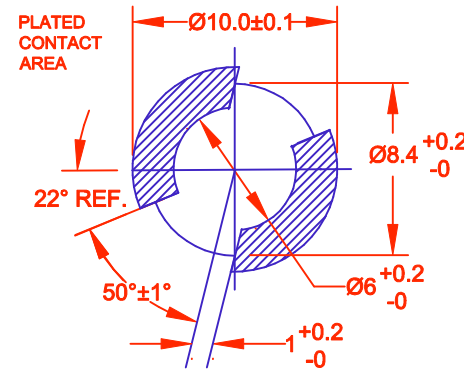

PC-BOARD THICKNESS: 1.6±0.1mm

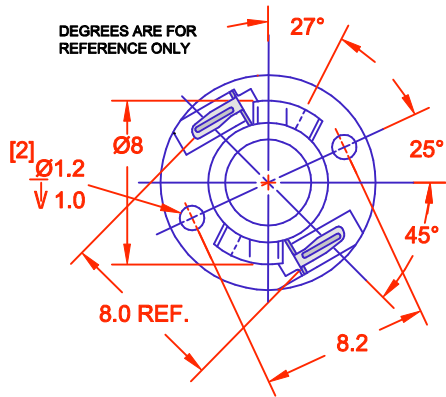
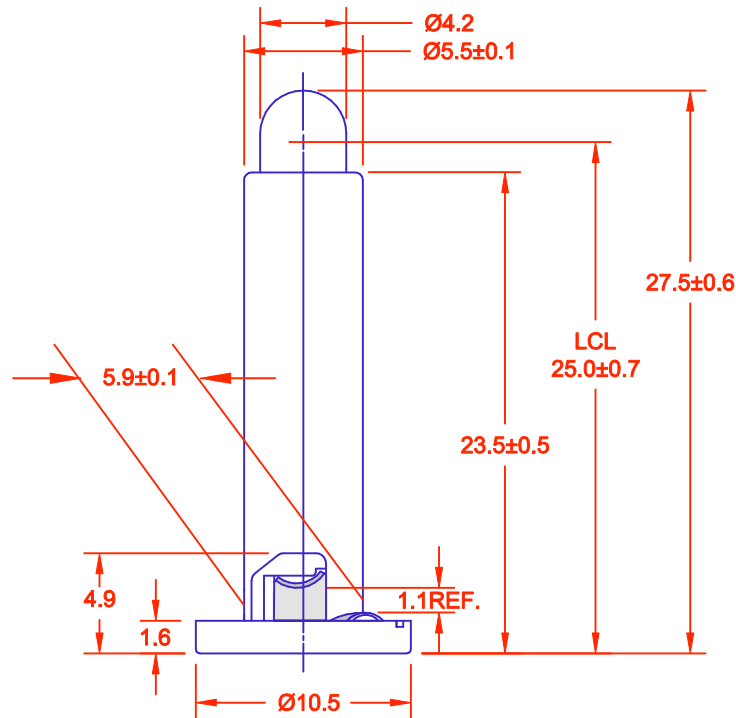

JKL PART NUMBER: DNW21-DW10/GRA/30MM

LAMP NUMBER: DW10/8.5					
VOLTS RATED	AMPS ± 10%	*MSCP ± 25%	*LUMENS ± 25%	AVERAGE LIFE HRS.	FILAMENT TYPE
14.0	.100	.500	6.29	5,000 D.C.	C-2F

*LAMP RATING ONLY WITHOUT BASE AND FILTER

BASE COLOR
GRAY

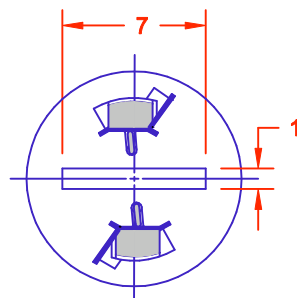

<p>METRIC</p> <p>THIRD ANGLE PROJECTION</p>	<p>DIMENSIONS ARE IN MILLIMETERS</p> <p>TOLERANCE UNLESS OTHERWISE SPECIFIED</p> <p>1 PL +/- 0.2</p> <p>2 PL +/- 0.20</p> <p>ANGLE +/- 0</p>	<p>JKL COMPONENTS CORPORATION</p>					
	<p>TITLE</p> <p>T-1 1/4 DOUBLE CONTACT NEO-WEDGE BASE WITH DW10/8.5 LAMP</p>	<p>SIZE</p> <p>A</p>	<p>FSCM NO.</p> <p>55335</p>	<p>DRAWING NO.</p> <p>DNW21-DW10/GRA/30MM</p>	<p>RELEASED DATE</p> <p>10/16/00</p>	<p>REVISION DATE</p> <p>10/23/01</p>	<p>REV. NO.</p> <p>A</p>
<p>DRAWN BY</p> <p>L. WENGSTROM</p>		<p>APP'VD BY</p> <p>J.K.</p>	<p>DATE</p> <p>10/23/01</p>	<p>- CAD DRAWING -</p> <p>MANUAL REVISIONS NOT PERMITTED</p>			