

8mm X 573.5mm RGB LED LIGHT BAR

FEATURES

VOLTAGE: 12V DC.

CURRENT: 600mA.

LED VIEWING ANGLE (2 θ 1/2): 100°.

PACKAGE: 1 PC/PVC TUBE.

PCB THICKNESS: 1.6mm

FULL COLOR CAPABILITY

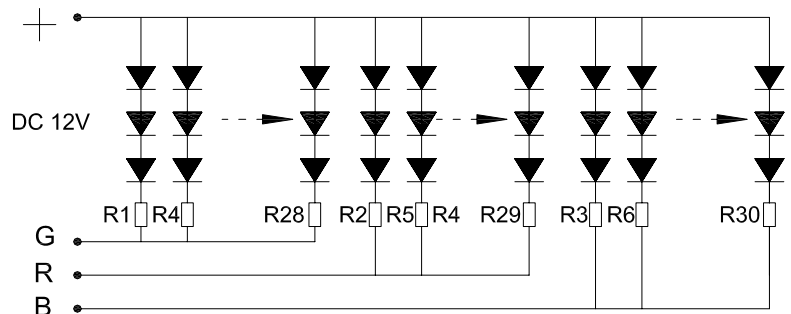
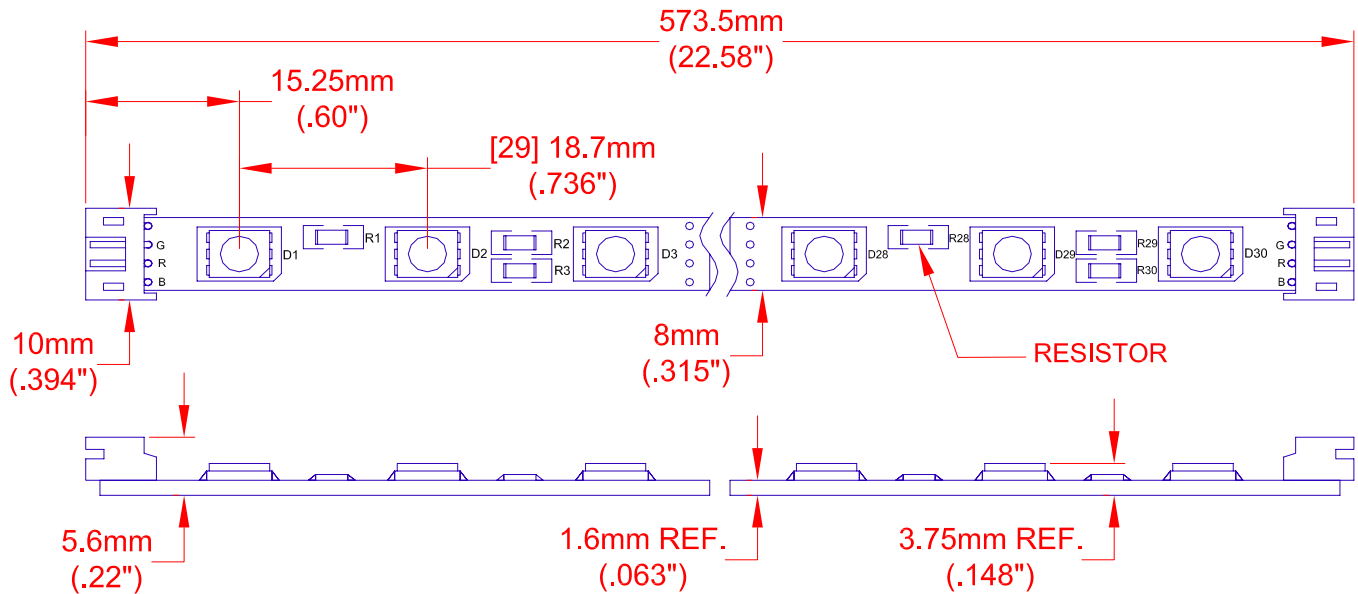
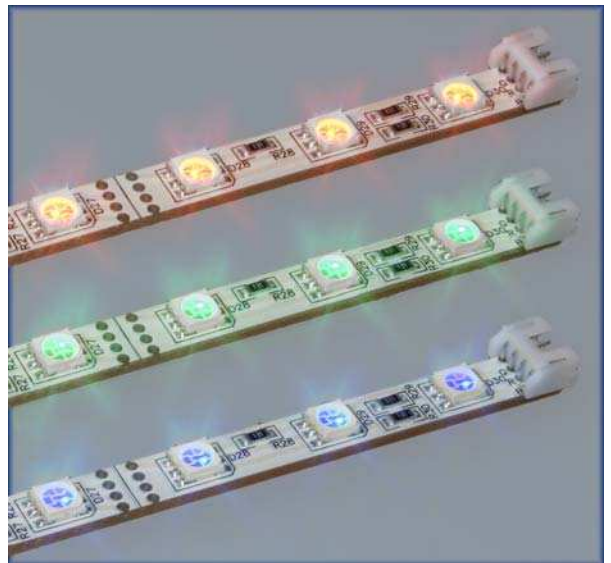

ATTENTION



OBSERVE PRECAUTION FOR HANDLING ELECTROSTATIC DISCHARGE SENSITIVE DEVICES

JKL PART NO.: ZRS-10573-RGB

| | | | | | | | |
|---------------------------------------------|--|--------------------------------------------------------------------------------------------------------------|--|-----------------------------------|---------------------------|-------------------------------------|--|
| METRIC THIRD ANGLE PROJECTION | | DIMENSIONS ARE IN MILLIMETERS TOLERANCE UNLESS OTHERWISE SPECIFIED 1 PL +/- REF. 2 PL +/- ANGLE +/- | | JKL COMPONENTS CORPORATION | | | |
| DRAWN BY L. WENGSTROM | | APPV'D BY S.C. | | SIZE A | FSCM NO. 55335 | DRAWING NO. ZRS-10573-RGB | |
| REV. NO. | | DESCRIPTION/ECO NUMBER | | SCALE NONE | RELEASED DATE 12/11/07 | REVISION DATE 3/12/08 | |
| REV. NO. | | APPV'D DATE | | TITLE RGB LED LIGHT BAR | | REV. NO. B | |
| REV. NO. | | APPV'D DATE | | SHEET 1 OF 2 | | MANUAL REVISIONS NOT PERMITTED | |

| | | |
|---|---------------------------|----------|
| B | ADD DIM'S & FEATURES | 3/12/08 |
| A | ADD ACCESSORIES NOTE PG 2 | 1/31/08 |
| | RELEASED | 12/11/07 |

8mm X 573.5mm RGB LED LIGHT BAR

Absolute Maximum Rating at TA = 25°C

| Parameter | Symbol | Absolute Maximum Rating | Unit |
|-------------------------|--------|-------------------------|------|
| Forward Current | IF | 600 | mA |
| Power Dissipation | PD | 7.2 | W |
| Electrostatic Discharge | ESD | 800 | V |
| Operating Temperature | Topr | -25~+60 | °C |
| Storage Temperature | Tstg | -40~+80 | °C |

Electrical/Optical Characteristics at TA = 25°C

| Parameter | Symbol | Color | Condition | Min | Typ | Max | Unit |
|---------------------------|-------------|-------|------------|-----|-----|-----|------|
| Forward Voltage DC | VF | RGB | IF = 600mA | -- | 12 | -- | V |
| Dominant Wavelength | λD | R | IF = 200mA | -- | 624 | -- | nm |
| | | G | IF = 200mA | -- | 518 | -- | |
| | | B | IF = 200mA | -- | 471 | -- | |
| Luminous Flux | ϕV | R | IF = 200mA | -- | 21 | -- | lm |
| | | G | IF = 200mA | -- | 55 | -- | |
| | | B | IF = 200mA | -- | 21 | -- | |
| Recommend Forward Current | IF | -- | -- | -- | 600 | -- | mA |

JKL ACCESSORIES TO BE ORDERED SEPARATELY:

PCB MOUNTING CLIP: **ZRC-8**

INPUT CONNECTOR HARNESS: **ZCH-110-RGB-I**

JOINER CONNECTOR HARNESS: **ZCH-110-RGB-J**

LIGHTING COLOR REMOTE CONTROLLER: **ZCTR-01-RGB**