



## ± 4g Tri-axis Analog Accelerometer Specifications

PART NUMBER:

KXTC8-1071  
Rev. 1  
May-2012

### Product Description

The KXTC8-1071 is a Tri-axis, silicon micromachined accelerometer with a full-scale output range of +/-4g (39.2 m/s/s). The sense element is fabricated using Kionix's proprietary plasma micromachining process technology. Acceleration sensing is based on the principle of a differential capacitance arising from acceleration-induced motion of the sense element, which further utilizes common mode cancellation to decrease errors from process variation, temperature, and environmental stress. The sense element is hermetically sealed at the wafer level by bonding a second silicon lid wafer to the device using a glass frit. A separate ASIC device packaged with the sense element provides signal conditioning and self-test. The accelerometer is delivered in a 4 x 4 x 1.3mm Land Grid Array (LGA) plastic package operating from a 1.8 – 3.6V DC supply. The KXTC8 features a factory programmable low pass filter, eliminating the need for external filter capacitors on the acceleration outputs.

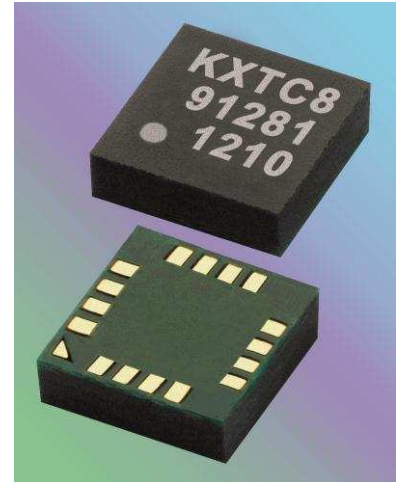

There are 2 factory programmable modes of operation for the KXTC8:

**Mode 00** – The Power Down pin must be **high** for normal operation and **low** for power shutdown.

**Mode 01** – The Power Down pin must be **low** for normal operation and **high** for power shutdown.

The KXTC8-1071 is factory programmed to be in MODE 01.



# ± 4g Tri-axis Analog Accelerometer Specifications

PART NUMBER:

KXTC8-1071

Rev. 1

May-2012

## Functional Diagram

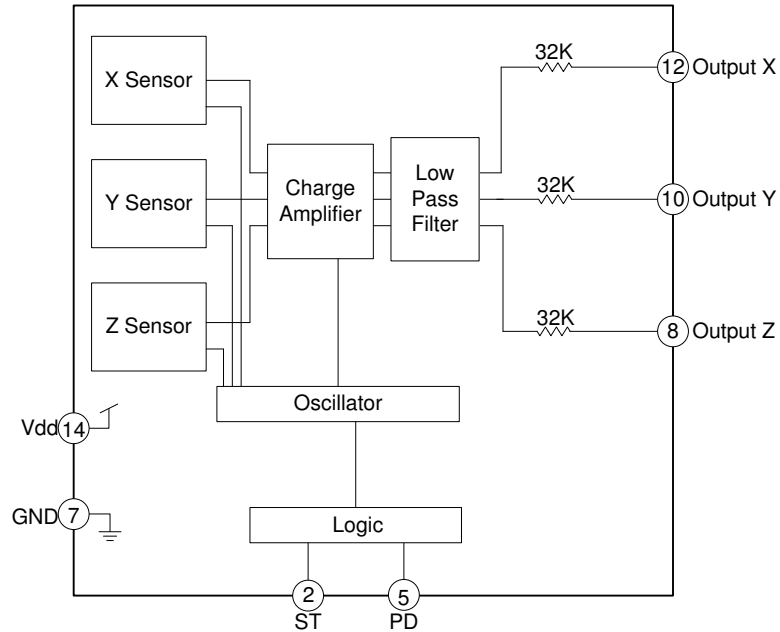



# ± 4g Tri-axis Analog Accelerometer Specifications

**PART NUMBER:**

**KXTC8-1071  
Rev. 1  
May-2012**

## Product Specifications

**Table 1. Mechanical**

(specifications are for operation at 3.3V and T = 25C unless stated otherwise)

Parameters	Units	Min	Typical	Max
Operating Temperature Range	°C	-40	-	85
Zero-g Offset	V	1.6	1.65	1.7
Zero-g Offset Variation from RT over Temp.	mg/°C		0.7	
Sensitivity	mV/g	320	330	340
Sensitivity Variation from RT over Temp.	%/°C		0.01 (xy) 0.03 (z)	
Offset Ratiometric Error ( $V_{dd} = 3.3V \pm 5\%$ )	%		0.2	
Sensitivity Ratiometric Error ( $V_{dd} = 3.3V \pm 5\%$ )	%		0.4 (xy) 0.15 (z)	
Self Test Output change on Activation	g		2.7 (x) 2.6 (y) 1.8 (z)	
Mechanical Resonance (-3dB) <sup>1</sup>	Hz		3500 (xy) 1800 (z)	
Non-Linearity	% of FS		0.2	
Cross Axis Sensitivity	%		2	
Noise Density (on filter pins)	μg / √Hz		130	

Notes:

1. Resonance as defined by the dampened mechanical sensor.



## ± 4g Tri-axis Analog Accelerometer Specifications

PART NUMBER:

KXTC8-1071  
Rev. 1  
May-2012

**Table 2. Electrical**

(specifications are for operation at 3.3V and T = 25C unless stated otherwise)

Parameters		Units	Min	Typical	Max
Supply Voltage (V <sub>dd</sub> )	Operating	V	1.8	3.3	3.6
Current Consumption	Operating (full power)	μA	180	230	280
	Standby	μA		5	
Analog Output Resistance(R <sub>out</sub> )		kΩ	24	32	40
Power Up Time <sup>1</sup>		ms	-	5*R <sub>out</sub> *C	-
Bandwidth (-3dB) <sup>2</sup>		Hz		no low pass	

Notes:

1. Power up time is determined by 5 times the RC time constant of the factory programmed or user defined low pass filter.
2. Factory programmable to have a switched capacitor low pass filter at 2kHz, 1kHz, 500Hz, 100Hz, 50Hz, or no low pass filter. Optionally, the user can define with external capacitors. Maximum defined by the frequency response of the sensors.

	<b>± 4g Tri-axis Analog Accelerometer Specifications</b>	<b>PART NUMBER:</b>  <b>KXTC8-1071</b> <b>Rev. 1</b> <b>May-2012</b>
---	--	--

**Table 3. Environmental**

Parameters		Units	Min	Typical	Max
Supply Voltage (V <sub>dd</sub> )	Absolute Limits	V	-0.3	-	6.0
Operating Temperature Range		°C	-40	-	85
Storage Temperature Range		°C	-55	-	150
Mech. Shock (powered and unpowered)		g	-	-	5000 for 0.5ms 10000 for 0.2ms
ESD	HBM	V	-	-	2000



Caution: ESD Sensitive and Mechanical Shock Sensitive Component, improper handling can cause permanent damage to the device.



This product conforms to Directive 2002/95/EC of the European Parliament and of the Council of the European Union (RoHS). Specifically, this product does not contain lead, mercury, cadmium, hexavalent chromium, polybrominated biphenyls (PBB), or polybrominated diphenyl ethers (PBDE) above the maximum concentration values (MCV) by weight in any of its homogenous materials. Homogenous materials are "of uniform composition throughout."



This product is halogen-free per IEC 61249-2-21. Specifically, the materials used in this product contain a maximum total halogen content of 1500 ppm with less than 900-ppm bromine and less than 900-ppm chlorine.

## Soldering

Soldering recommendations are available upon request or from [www.kionix.com](http://www.kionix.com).



# ± 4g Tri-axis Analog Accelerometer Specifications

**PART NUMBER:**

**KXTC8-1071**  
Rev. 1  
May-2012

## Application Schematic

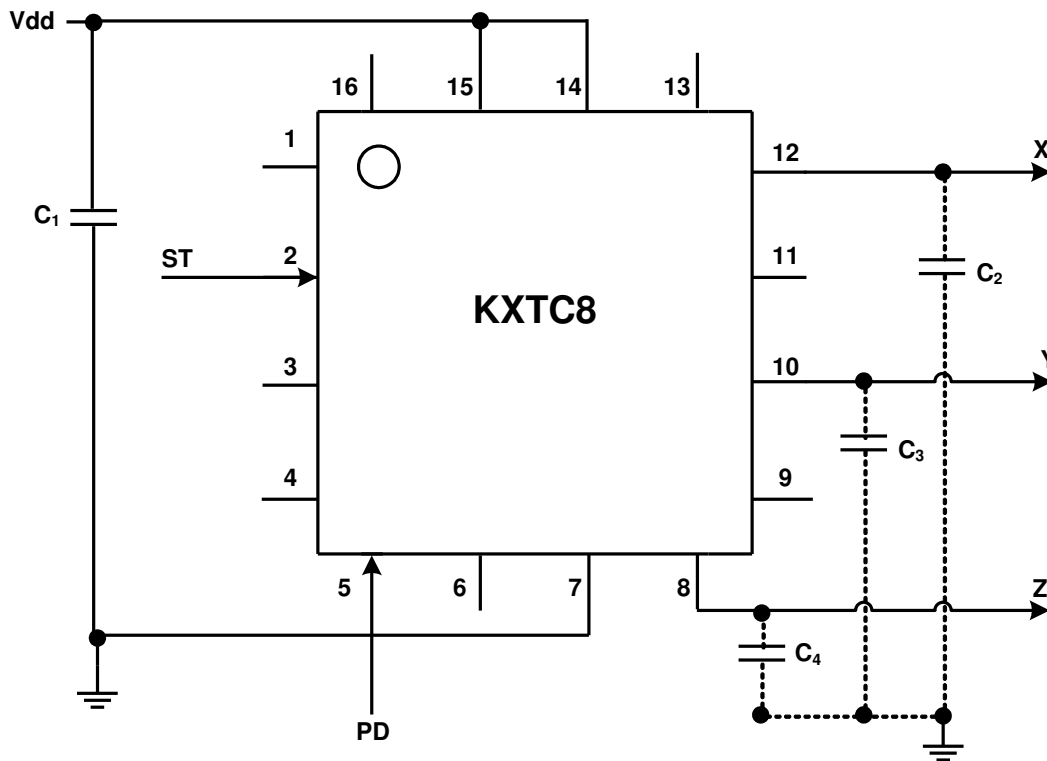

**Table 4. KXTC8 Pin Descriptions**

Pin	Name	Description
1	NC	Not Connected Internally
2	ST	Self Test (0=normal operating mode, 1 = self test mode)
3	NC	Not Connected Internally
4	NC	Not Connected Internally
5	PD	Power Down (0 = Enabled, 1 = Disabled)
6	NC	Not Connected Internally
7	GND	Ground
8	Z Output	Analog output of the z-channel. Optionally, a capacitor ( $C_4$ ) placed between this pin and ground will form a low pass filter.
9	NC	Not Connected Internally
10	Y Output	Analog output of the y-channel. Optionally, a capacitor ( $C_3$ ) placed between this pin and ground will form a low pass filter.
11	NC	Not Connected Internally
12	X Output	Analog output of the x-channel. Optionally, a capacitor ( $C_2$ ) placed between this pin and ground will form a low pass filter.
13	NC	Not Connected Internally
14	Vdd	The power supply input. Decouple this pin to ground with a 0.1uF ceramic capacitor ( $C_1$ ).
15	NC	Connect to Vdd or GND
16	NC	Not Connected Internally



## ± 4g Tri-axis Analog Accelerometer Specifications

PART NUMBER:

KXTC8-1071  
Rev. 1  
May-2012

### Application Design Equations

The bandwidth is determined by a factory programmable switched capacitor filter. The filter can be set at the factory to be 2kHz, 1kHz, 500Hz, 100Hz, 50Hz, or no low pass filter. Alternatively, bandwidth can be reduced by addition of a capacitor on the output pins 8, 10, and 12 according to the equation:

$$C_2 = C_3 = C_4 = \frac{4.97 \times 10^{-6}}{f_{BW}}$$

#### Note:

When the PD pin is connected to Vdd or left floating, the KXTC8 is shutdown and drawing very little power. When the PD pin is tied to GND, the unit is fully functional.

### Test Specifications



#### Special Characteristics:

These characteristics have been identified as being critical to the customer. Every part is tested to verify its conformance to specification prior to shipment.

**Table 5. Test Specifications**

Parameter	Specification	Test Conditions
Zero-g Offset @ RT	1.65 +/- 0.0495 V	25C, Vdd = 3.3 V
Sensitivity @ RT	330 +/- 9.9 mV/g	25C, Vdd = 3.3 V
Current Consumption -- Operating	180 <= Idd <= 280 uA	25C, Vdd = 3.3 V



# ± 4g Tri-axis Analog Accelerometer Specifications

PART NUMBER:

KXTC8-1071  
Rev. 1  
May-2012

## Package Dimensions and Orientation

4 x 4 x 1.3 mm LGA

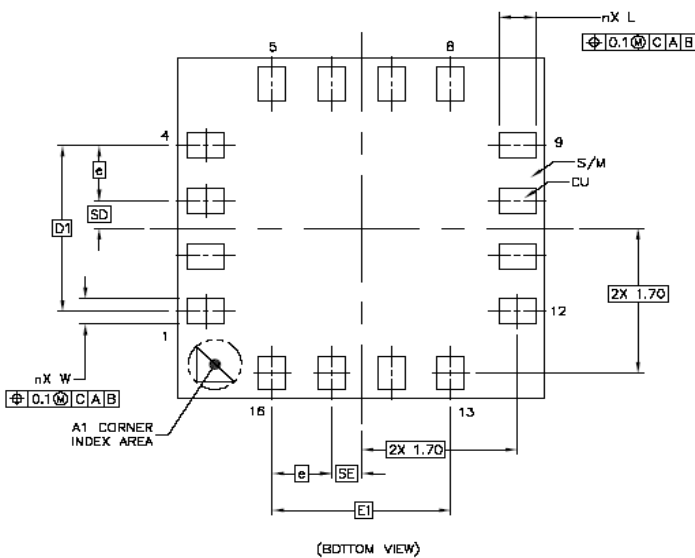
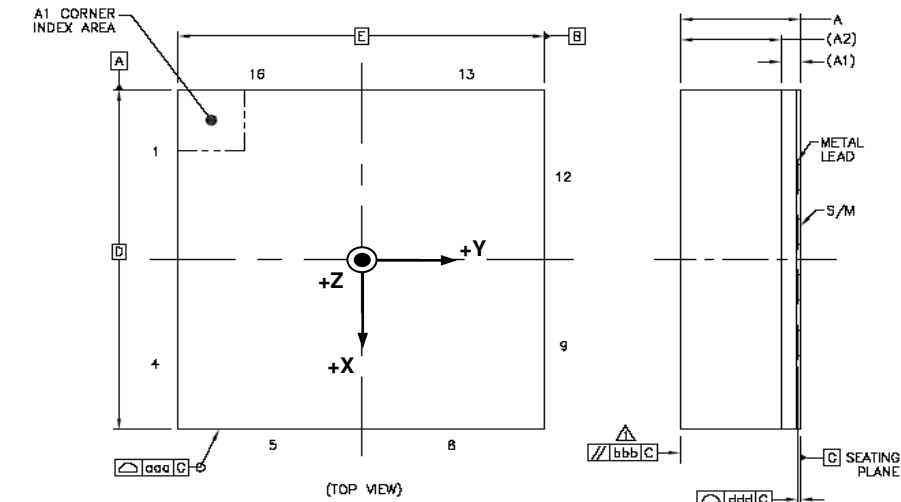

	SYMBOL	COMMON DIMENSIONS		
		MIN.	NDR.	MAX.
TOTAL THICKNESS	A	----	1.31	1.33
SUBSTRATE THICKNESS	A1	0.21	REF	
MOLD THICKNESS	A2	1.1	REF	
BODY SIZE	D	4	BSC	
	E	4	BSC	
LEAD WIDTH	W	0.25	0.3	0.35
LEAD LENGTH	L	0.35	0.4	0.45
LEAD PITCH	e	0.65	BSC	
LEAD COUNT	n	16		
EDGE BALL CENTER TO CENTER	D1	1.95	BSC	
	E1	1.95	BSC	
BODY CENTER TO CONTACT BALL	SD	0.325	BSC	
	SE	0.325	BSC	
BALL WIDTH	b	----	----	----
BALL DIAMETER		----	----	----
BALL OPENING		----	----	----
BALL PITCH	e1	----	----	----
BALL COUNT	n1	----	----	----
PRE-SOLDER		----	----	----
PACKAGE EDGE TOLERANCE	ooo	0.1		
MOLD FLATNESS	bbb	0.2		
COPLANARITY	ddd	0.08		
BALL OFFSET (PACKAGE)	eee	----	----	----
BALL OFFSET (BALL)	fff	----	----	----

NOTES:  
 ▲ PARALLELISM MEASUREMENT SHALL EXCLUDE ANY EFFECT OF MARK ON TOP SURFACE OF PACKAGE.

All dimensions and tolerances conform to ASME Y14.5M-1994

When device is accelerated in +X, +Y or +Z direction, the corresponding output will increase.





## ± 4g Tri-axis Analog Accelerometer Specifications

**PART NUMBER:**

**KXTC8-1071  
Rev. 1  
May-2012**

### Static X/Y/Z Output Response versus Orientation to Earth's surface (1-g):

Position	1	2	3	4	5	6
Diagram						
X	1.32 V	1.65 V	1.98 V	1.65 V	1.65 V	1.65 V
Y	1.65 V	1.98 V	1.65 V	1.32 V	1.65 V	1.65 V
Z	1.65 V	1.65 V	1.65 V	1.65 V	1.98 V	1.32 V
X-Polarity	-	0	+	0	0	0
Y-Polarity	0	+	0	-	0	0
Z-Polarity	0	0	0	0	+	-

↓ (1-g)

Earth's Surface



# ± 4g Tri-axis Analog Accelerometer Specifications

**PART NUMBER:**

**KXTC8-1071  
Rev. 1  
May-2012**

## Revision History

REVISION	DESCRIPTION	DATE
1	Initial Production Release	29-May-2012

"Kionix" is a registered trademark of Kionix, Inc. Products described herein are protected by patents issued or pending. No license is granted by implication or otherwise under any patent or other rights of Kionix. The information contained herein is believed to be accurate and reliable but is not guaranteed. Kionix does not assume responsibility for its use or distribution. Kionix also reserves the right to change product specifications or discontinue this product at any time without prior notice. This publication supersedes and replaces all information previously supplied.