

# Integrated Transceiver Modules for ZigBee / 802.15.4 (2.4 GHz) ZigBee Light Link (ZLL) Module

## FEATURES

- 100mW output power
- Long range: 4000 feet
- Miniature footprint: 0.9" x 1.63"
- Integrated PCB F antenna or U.FL connector for external antenna
- FCC and IC certified
- Integrated 8051 microcontroller with 256k FLASH and 8k RAM
- 4MBit Serial FLASH
- Supports ZigBee Light Link (ZLL)
- Low power operation
- RoHS compliant
- Streamlined development with LSR design services.
- License options available to purchase design or integrate design.

## APPLICATIONS

- Lighting Control
- Smart Energy

## DESCRIPTION

The ProFLEX01-SOC module is a high performance 2.4 GHz ZigBee / IEEE 802.15.4 System-On-Chip (CC2530) radio/microcontroller and power amplifier (CC2591) in a cost effective, pre-certified footprint.



The module comes preloaded with the TI Z-Stack with the ZigBee Light Link protocol.

Full debug and programming capabilities are included to develop custom applications.

Need to get to market quickly? Not an expert in 802.15.4 or ZigBee? Need a custom antenna? Would you like to own the design? Would you like a custom design? Not quite sure what you need? Do you need help with your host board? LS Research Design Services will be happy to develop custom hardware or software, integrate the design, or license the design so you can manufacture yourself. Contact us at sales@lsr.com or call us at 262-375-4400.



## ORDERING INFORMATION

Order Number	Description
450-0035	ProFLEX01-SOC Module with PCB F antenna
450-0044	ProFLEX01-SOC Module with U.FL connector for external antenna
450-0051	ProFLEX01-SOC Development Kit

**Table 1 Orderable ProFLEX01-SOC Model Numbers**

The information in this document is subject to change without notice.

**MODULE ACCESSORIES**

	Order Number	Description
	<b>001-0001</b>	2.4 GHz Dipole Antenna with Reverse Polarity SMA Connector
	<b>080-0001</b>	U.FL to Reverse Polarity SMA Bulkhead Cable 105mm

**BLOCK DIAGRAM**

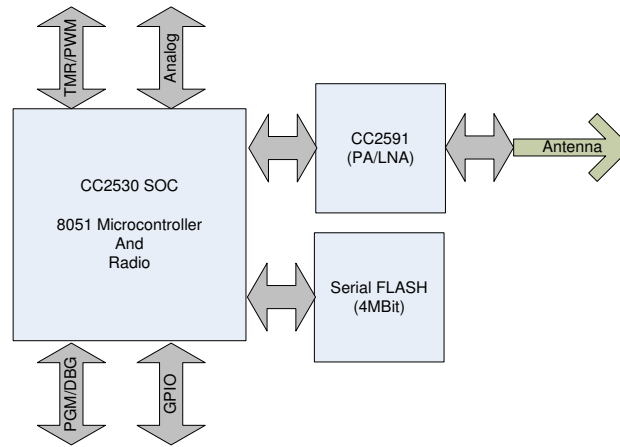

**Figure 1 ProFLEX01-SOC Module Block Diagram – High-Level**

---

**TABLE OF CONTENTS**

---

<b>FEATURES .....</b>	<b>1</b>
<b>APPLICATIONS.....</b>	<b>1</b>
<b>DESCRIPTION .....</b>	<b>1</b>
<b>ORDERING INFORMATION .....</b>	<b>1</b>
<b>MODULE ACCESSORIES.....</b>	<b>2</b>
<b>BLOCK DIAGRAM.....</b>	<b>3</b>
<b>MODULE PINOUT AND PIN DESCRIPTIONS .....</b>	<b>6</b>
<b>MODULE OVERVIEW.....</b>	<b>10</b>
<b>SOC Microcontroller.....</b>	<b>10</b>
<b>SOC Radio .....</b>	<b>10</b>
<b>PA/LNA.....</b>	<b>12</b>
<b>Antenna Options.....</b>	<b>12</b>
<b>Serial FLASH Memory .....</b>	<b>13</b>
<b>DEVELOPMENT TOOLS.....</b>	<b>14</b>
<b>TI CC-DEBUGGER .....</b>	<b>14</b>
<b>IAR Embedded Workbench for 8051.....</b>	<b>14</b>
<b>ELECTRICAL SPECIFICATIONS.....</b>	<b>15</b>
<b>Absolute Maximum Ratings.....</b>	<b>15</b>
<b>Recommended Operating Conditions .....</b>	<b>15</b>
<b>General Characteristics.....</b>	<b>16</b>
<b>RF Characteristics.....</b>	<b>17</b>
<b>SOLDERING RECOMMENDATIONS.....</b>	<b>21</b>
<b>Recommended Reflow Profile for Lead Free Solder.....</b>	<b>21</b>
<b>CLEANING.....</b>	<b>22</b>
<b>OPTICAL INSPECTION .....</b>	<b>22</b>
<b>REWORK .....</b>	<b>22</b>
<b>SHIPPING, HANDLING, AND STORAGE .....</b>	<b>22</b>
<b>Shipping.....</b>	<b>22</b>

---

The information in this document is subject to change without notice.

---

Handling.....	22
Moisture Sensitivity Level (MSL) .....	22
Storage.....	22
Repeating Reflow Soldering .....	23
<b>AGENCY STATEMENTS .....</b>	<b>24</b>
Agency Certifications.....	24
<b>MECHANICAL DATA.....</b>	<b>29</b>
PCB Footprint .....	29
General Module Dimensions.....	30
<b>COMPATIBILITY .....</b>	<b>31</b>
<b>MODULE REVISION HISTORY .....</b>	<b>32</b>
Rev 1 .....	32
<b>CONTACTING LS RESEARCH .....</b>	<b>33</b>

**MODULE PINOUT AND PIN DESCRIPTIONS**

MCU#	GND	1	Texas Instruments CC2530																	69	GND	MCU#
-	GND	2																		68	GND	-
-	GND	3																		67	GND	-
-	NC	4																		66	NC	-
-	NC	5																		65	NC	-
-	NC	6																		64	NC	-
-	NC	7																		63	NC	-
-	NC	8																		62	NC	-
-	NC	9																		61	P0.3/W LED	16
35	Debug Data	10																		60	P0.2	17
34	Debug Clock	11																		59	P0.5/G LED	14
-	NC	12																		58	P0.4/B LED	15
-	NC	13																		57	NC	-
20	nRESET	14																		56	NC	-
-	NC	15																		55	NC	-
-	NC	16																		54	NC	-
-	NC	17																		53	NC	-
-	NC	18																		52	NC	-
-	NC	19																		51	NC	-
19	P0.0/Mode	20																		50	NC	-
-	NC	21																		49	NC	-
12	P0.7/Button	22																		48	NC	-
-	NC	23																		47	NC	-
-	NC	24																		46	NC	-
-	NC	25																		45	NC	-
-	VCC - 3V3DC	26																		44	GND	-
		27	28	29	30	31	32	33	34	35	36	37	38	39	40	41	42	43				
		P2.0	P1.0	P1.2/Light Sel	NC	P0.7/Button	NC	NC	NC	P1.6	P1.7/R LED	NC	NC	NC	NC	NC	NC	NC				
MCU#		36	11	8	-	12	-	-	-	38	37	-	-	-	-	-	-	-	MCU#			

**Figure 2 Module Pinout**

Module Pin	Name	MCU Pin	Type	Description
1	GND	N/A	GND	Ground
2	GND	N/A	GND	Ground
3	GND	N/A	GND	Ground
4	NC	N/A	NC	No Connect
5	NC	N/A	NC	No Connect
6	NC	N/A	NC	No Connect
7	NC	N/A	NC	No Connect
8	NC	N/A	NC	No Connect
9	NC	N/A	NC	No Connect
10	Debug Data	35	I/O	Debug Data signal for programming/debugging.
11	Debug Clock	34	Input	Debug Clock signal for programming/debugging.
12	NC	N/A	NC	No Connect
13	NC	N/A	NC	No Connect
14	nRESET	20	Input	RESET
15	NC	N/A	NC	No Connect
16	NC	N/A	NC	No Connect
17	NC	N/A	NC	No Connect
18	NC	N/A	NC	No Connect
19	NC	N/A	NC	No Connect
20	P0.0	19	I/O	General-purpose digital I/O or Mode select. With the ZLL firmware this pin will select test mode or normal mode. Logic low will select test mode For peripheral functionality see CC2530 User's Guide.
21	NC	N/A	NC	No Connect
22	P0.7	12	I/O	General-purpose digital I/O or button input. With the ZLL firmware this pin can be used as a multi-function button. For peripheral functionality see CC2530 User's Guide.
23	NC	N/A	NC	No Connect
24	NC	N/A	NC	No Connect
25	NC	N/A	NC	No Connect
26	VCC - 3V3DC	VCC	VCC	Supply Voltage
27	P2.0	36	I/O	General-purpose digital I/O or analog input. For peripheral functionality see CC2530 User's Guide.
28	P1.0	11	I/O	General-purpose digital I/O or analog input. For peripheral functionality see CC2530 User's Guide.

The information in this document is subject to change without notice.

Module Pin	Name	MCU Pin	Type	Description
29	P1.2	8	I/O	General-purpose digital I/O or light select. With the ZLL firmware this pin will be used to select whether the light is a white fixture or and RGB light. Logic low will select RGB light. For peripheral functionality see CC2530 User's Guide.
30	NC	N/A	NC	No Connect
31	P0.7	12	I/O	General-purpose digital I/O or button input. With the ZLL firmware this pin can be used as a multi-function button. For peripheral functionality see CC2530 User's Guide.
32	NC	N/A	NC	No Connect
33	NC	N/A	NC	No Connect
34	NC	N/A	NC	No Connect
35	P1.6	38	I/O	General-purpose digital I/O UART transmit data output in test mode. For peripheral functionality see CC2530 User's Guide.
36	P1.7/Red LED PWM	37	I/O	General-purpose digital I/O UART receive data input in test mode. Red LED PWM in normal mode. For peripheral functionality see CC2530 User's Guide.
37	NC	N/A	NC	No Connect
38	NC	N/A	NC	No Connect
39	NC	N/A	NC	No Connect
40	NC	N/A	NC	No Connect
41	NC	N/A	NC	No Connect
42	NC	N/A	NC	No Connect
43	NC	N/A	NC	No Connect
44	GND	N/A	GND	Ground
45	NC	N/A	NC	No Connect
46	NC	N/A	NC	No Connect
47	NC	N/A	NC	No Connect
48	NC	N/A	NC	No Connect
49	NC	N/A	NC	No Connect
50	NC	N/A	NC	No Connect
51	NC	N/A	NC	No Connect
52	NC	N/A	NC	No Connect
53	NC	N/A	NC	No Connect
54	NC	N/A	NC	No Connect
55	NC	N/A	NC	No Connect

The information in this document is subject to change without notice.



Module Pin	Name	MCU Pin	Type	Description
56	NC	N/A	NC	No Connect
57	NC	N/A	NC	No Connect
58	P0.4/Blue LED PWM	15	I/O	General-purpose digital I/O or blue LED PWM. For peripheral functionality see CC2530 User's Guide.
59	P0.5/Green LED PWM	14	I/O	General-purpose digital I/O or green LED PWM. For peripheral functionality see CC2530 User's Guide.
60	P0.2	17	I/O	General-purpose digital I/O or analog input. For peripheral functionality see CC2530 User's Guide.
61	P0.3/White LED PWM	16	I/O	General-purpose digital I/O or white LED PWM. For peripheral functionality see CC2530 User's Guide.
62	NC	N/A	NC	No Connect
63	NC	N/A	NC	No Connect
64	NC	N/A	NC	No Connect
65	NC	N/A	NC	No Connect
66	NC	N/A	NC	No Connect
67	GND	N/A	GND	Ground
68	GND	N/A	GND	Ground
69	GND	N/A	GND	Ground

**Table 2 ProFLEX01-SOC Module Pin Descriptions**

## MODULE OVERVIEW

Figure 3 below shows the internal interconnects of the ICs on the ProFLEX01-SOC module. Consult the respective IC datasheets for details, or contact LSR sales to purchase the ProFLEX01-SOC module schematics as part of LSR’s ModFLEX™ design program. For a high-level block diagram of the ProFLEX01-SOC module, see Figure 1.

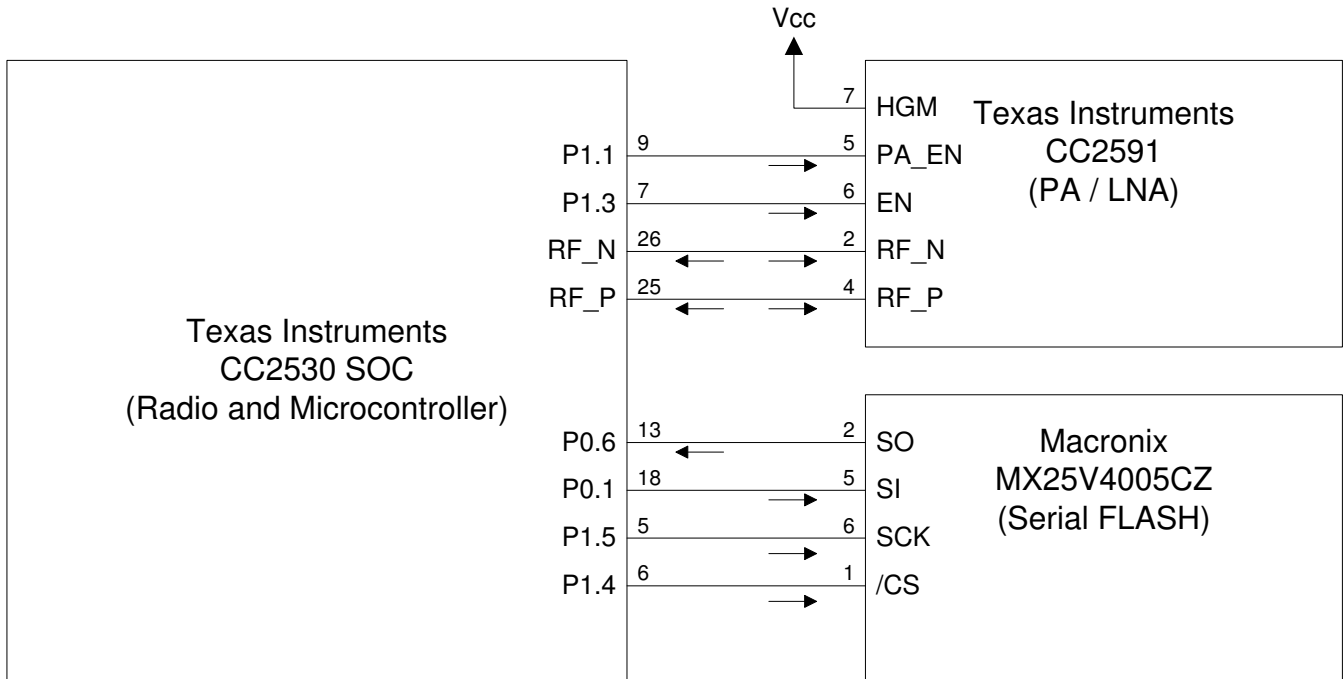

**Figure 3 ProFLEX01-SOC Module Block Diagram – Internal Interconnects**

## SOC Microcontroller

The 8051 CPU core used in the CC2530 SOC is a single-cycle 8051-compatible core. It has three different memory access buses (SFR, DATA and CODE/XDATA) with single-cycle access to SFR, DATA, and the main SRAM. It also includes a debug interface and an 18-input extended interrupt unit. The interrupt controller services a total of 18 interrupt sources, divided into six interrupt groups, each of which is associated with one of four interrupt priorities. Any interrupt service request is serviced also when the device is in idle mode by going back to active mode. Some interrupts can also wake up the device from sleep mode (power modes 1–3). Figure 4 shows a block diagram of the CC2530.

## SOC Radio

The CC2530 device family provides an IEEE 802.15.4-compliant radio transceiver for the 2.4 GHz unlicensed ISM band. The RF core controls the analog radio modules. The radio provides extensive hardware support for frame handling, data buffering, burst transmissions, clear channel assessment, link quality indication and frame timing information. In addition, it provides an interface between the MCU and the radio which makes it possible to issue commands, read status, and automate and sequence radio events. The radio also includes a packet-filtering and address-recognition module.

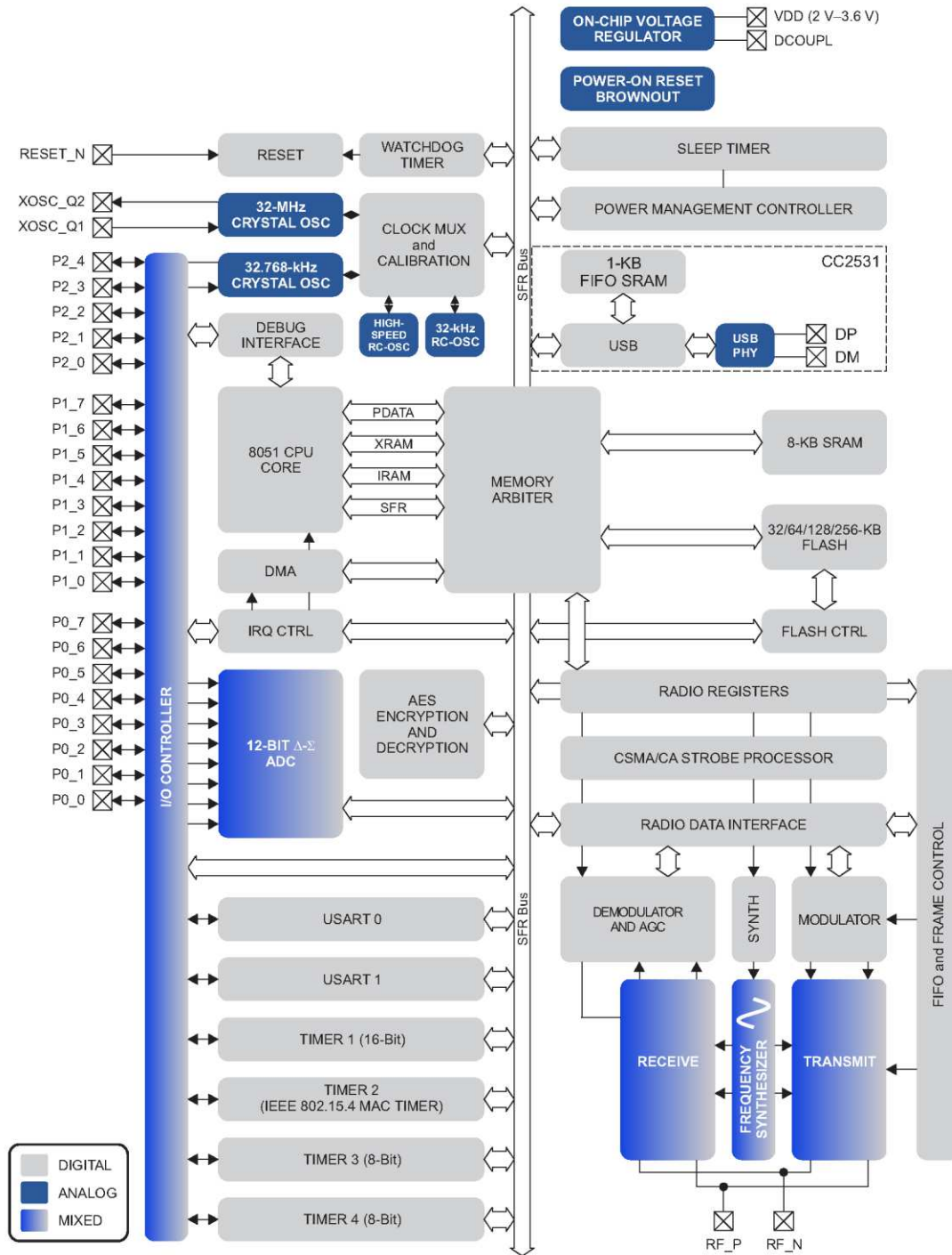
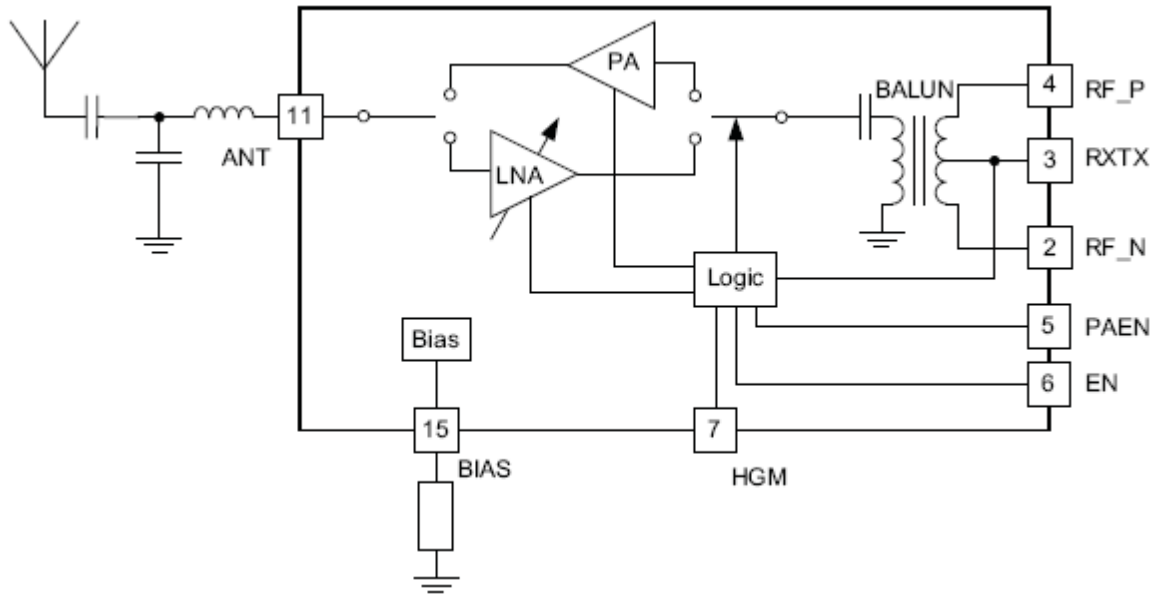

**Figure 4 CC2530 SOC Block Diagram**

The information in this document is subject to change without notice.

## PA/LNA

The CC2591 is a cost-effective and high performance RF Front End for low-power and low-voltage 2.4 GHz wireless applications. It is a range extender for all existing and future 2.4 GHz low-power RF transceivers, transmitters and System-on-Chip products from Texas Instruments. It increases the link budget by providing a power amplifier for increased output power, and a LNA with low noise figure for improved receiver sensitivity. It provides a small size, high output power RF design with its 4x4-mm QFN-16 package. It contains PA, LNA, switches, RF-matching, and balun for simple design of high performance wireless applications. Figure 5 shows a block diagram of the CC2591.



**Figure 5 CC2591 Block Diagram**

## Antenna Options

The ProFLEX01-SOC module includes an integrated PCB F-antenna. An optional configuration with a u.fl connector is also available. The module regulatory certification has been completed with the following antennas:

- PCB trace antenna
- LS Research 001-0001 2.4 GHz Dipole Antenna with Reverse Polarity SMA Connector and LS Research 080-0001 u.fl to Reverse Polarity SMA Bulkhead Cable (105mm in length)

An adequate ground plane is necessary to provide good efficiency. The ground plane of the host board on which the module is mounted increases the effective antenna ground plane size and improves the antenna performance.

The environment the module is placed in will dictate the range performance. The non-ideal characteristics of the environment will result in the transmitted signal being reflected, diffracted, and scattered. All of these factors randomly combine to create extremely complex scenarios that will affect the link range in various ways.

It is also best to keep some clearance between the antenna and nearby objects. This includes how the module is mounted in the product enclosure. Unless the items on the following list of recommendations are met, the radiation pattern can be heavily distorted.

Whichever antennas are used, it is best to keep a few things in mind when determining their location.

- Never place ground plane or copper trace routing underneath the antenna.
- LSR recommends keeping metal objects as far away from the antenna as possible. At a very minimum keep the antennas at least 16mm from any metallic objects, components, or wiring. The farther the antenna is placed from these interferers, the less the radiation pattern and gain will be perturbed
- Do not embed the antenna in a metallic or metalized plastic enclosure.
- Try to keep any plastic enclosure greater than 1 cm from the antenna in any orientation.

### Serial FLASH Memory

The ProFLEX01-SOC module includes a 4MBit (512k Byte) serial FLASH memory chip. The primary intention of the serial FLASH is to support applications that require Over-The-Air (OTA) firmware downloading. For these applications the new firmware image can get sent to the module and stored in the serial FLASH. Once the complete firmware image is in the serial FLASH and has been verified as good, a bootloader can be invoked to copy the new firmware image from the serial FLASH into the CC2530 FLASH memory. In addition the serial FLASH could be used for data storage depending on the application requirements.

## DEVELOPMENT TOOLS

### TI CC-DEBUGGER

Custom firmware development can be done on the ProFLEX01-SOC module using development tools available through TI. Shown in Figure 6 is a USB CC-DEBUGGER, which can be used both for debugging or programming. It plugs directly into the ProFLEX01-SOC Development Board (see **Error! eference source not found.**), and can easily be adapted to other hardware. See the Texas Instruments website for more information.



**Figure 6 CC-DEBUGGER**

### IAR Embedded Workbench for 8051

Also required is Embedded Workbench for 8051 from IAR Systems. IAR Embedded Workbench for 8051 is an Integrated Development Environment (IDE) for building and debugging embedded applications. Visit the IAR Systems website for additional information.

## ELECTRICAL SPECIFICATIONS

The majority of these characteristics are based on the use of the TI 802.15.4 MAC loaded with the generic application firmware written by LSR. Custom firmware may require these values to be re-characterized by the customer.

### Absolute Maximum Ratings

Parameter	Min	Max	Unit
Power supply voltage ( $V_{CC}$ )	-0.2	+3.6	V
Voltage on any GPIO	-0.2	$V_{CC} + 0.2$	V
RF input power, antenna port		+10	dBm
RF input power, transmit port		+8	dBm
Operating temperature	-40	+85	°C
Storage temperature	-40	+105	°C

**Table 3 Absolute Maximum Ratings<sup>1</sup>**

### Recommended Operating Conditions

Parameter	Min	Typ	Max	Unit
Power supply voltage ( $V_{CC}$ )	2.4	3.3	3.5	Vdc
Input frequency	2405		2480	MHz
Ambient temperature range	-40	25	85	°C

**Table 4 Recommended Operating Conditions**

**Module will NOT transmit, if  $V_{CC} > 3.55V$ .**

<sup>1</sup> Under no circumstances should exceeding the ratings specified in the Absolute Maximum Ratings section be allowed. Stressing the module beyond these limits may result permanent damage to the module that is not covered by the warranty.

### General Characteristics

Parameter	Min	Typ	Max	Unit
RF frequency range	2405		2480	MHz
RF data rate		250		kbps
Host data rate	1.2	19.2	921.6	kbps
Flash memory		256		kBytes
RAM		8		kBytes

**Table 5 General Characteristics**

### Power Consumption

Parameter	Test Conditions	Min	Typ	Max	Unit
Transmit mode	2440 MHz, 3.3V, +25°C, +20 dBm output, 50 Ω	130	160	195	mA
Receive mode	2440 MHz, 3.3V, +25°C, -50 dBm input	29	32	35	mA
Sleep mode			3	8	uA

**Table 6 Power Consumption**

### DC Characteristics – General Purpose I/O

Parameter	Test Conditions	Min	Typ	Max	Unit
Logic input low	V <sub>CC</sub> = 3.0V, +25°C			.5	V
Logic input high	V <sub>CC</sub> = 3.0V, +25°C	2.5			V
I/O-pin pullup and pulldown resistors	V <sub>CC</sub> = 3.0V, +25°C		20		kΩ
Logic output low (P1.0)	V <sub>CC</sub> = 3.0V, +25°C, I <sub>OUT</sub> = 20mA			.5	V
Logic output low (ALL I/O except P1.0)	V <sub>CC</sub> = 3.0V, +25°C, I <sub>OUT</sub> = 4mA			.5	V
Logic output high (P1.0)	V <sub>CC</sub> = 3.0V, +25°C, I <sub>OUT</sub> = -20mA	2.4			V
Logic output high (ALL I/O except P1.0)	V <sub>CC</sub> = 3.0V, +25°C, I <sub>OUT</sub> = -4mA	2.4			V

**Table 7 DC Characteristics General Purpose I/O**



## RF Characteristics

### Nominal Transmitter Characteristics ( $T_A = 25^\circ\text{C}$ , $V_{CC} = 3.3\text{V}$ , $f_c = 2440\text{ MHz}$ , $50\Omega$ )

Parameter	Test Conditions	Min	Typ	Max	Unit
Minimum output power	Min 802.15.4 MAC API Setting	7	9	11	dBm
Maximum output power	Max 802.15.4 MAC API Setting	18	20	22	dBm
Programmable output power range		9.5		20	dBm
Transmit current – min output	Min 802.15.4 MAC API Setting	75	78	85	mA
Transmit current – max output	Max 802.15.4 MAC API Setting	130	160	195	mA
Error vector magnitude			12	35	%

**Table 8 Nominal Transmitter RF Characteristics**

### Minimum Transmitter Characteristics ( $T_A = +85^\circ\text{C}$ , $V_{CC} = 2.4\text{V}$ , $f_c = 2440\text{ MHz}$ , $50\Omega$ )

Parameter	Test Conditions	Min	Typ	Max	Unit
Minimum output power	Min 802.15.4 MAC API Setting	2	4	6	dBm
Maximum output power	Max 802.15.4 MAC API Setting	16	17	19	dBm
Programmable output power range		4		17	dBm
Transmit current – min output	Min 802.15.4 MAC API Setting	70	73	76	mA
Transmit current – max output	Max 802.15.4 MAC API Setting	120	129	145	mA

**Table 9 Minimum Transmitter RF Characteristics**

The information in this document is subject to change without notice.

**Maximum Transmitter Characteristics**  
 (T<sub>A</sub> = -40 °C, V<sub>CC</sub> = 3.6V, f<sub>C</sub> = 2440 MHz, 50Ω)

Parameter	Test Conditions	Min	Typ	Max	Unit
Minimum output power	Min 802.15.4 MAC API Setting	13	14	15	dBm
Maximum output power	Max 802.15.4 MAC API Setting	21	23	24	dBm
Programmable output power range		14		23	dBm
Transmit current – min output	Min 802.15.4 MAC API Setting	80	87	95	mA
Transmit current – max output	Max 802.15.4 MAC API Setting	219	276	355	mA

**Table 10 Maximum Transmitter RF Characteristics**

**RF Power Settings**  
 (T<sub>A</sub> = 25 °C, V<sub>CC</sub> = 3.3V, f<sub>C</sub> = 2440 MHz, 50Ω)

Radio TXPOWER Register Value	RF Output Power	Typical Current Consumption
0x65	8.8 dBm	77mA
0x75	10.4 dBm	81mA
0x85	11.8 dBm	86mA
0x95	13.0 dBm	90mA
0xA5	14.9 dBm	101mA
0xB5	16.5 dBm	112mA
0xD5	18.6 dBm	133mA
0xF5	21.1 dBm	179mA

**Table 11 RF Power Settings with LSR Host Software**

Tables 10-12 below list the RF Power Limits per channel that must be maintained to assure compliance with FCC or ETSI.

RF Channel	Radio TXPOWER Register Value	RF Output Power
11		
12		
13		
14		
15		
16		
17		
18		
19		
20		
21		
22		
23		
24		
25		
26	Not used	Not used

**Table 12 RF Transmit Output Power Limits for FCC Compliance (Internal or External Antenna)**

RF Channel	Radio TXPOWER Register Value	RF Output Power
11		
12		
13		
14		
15		
16		
17		
18		
19		
20		
21		
22		
23		
24		
25		
26		

**Table 13 RF Transmit Output Power Limits for ETSI Compliance (Internal Antenna)**

RF Channel	Radio TXPOWER Register Value	RF Output Power
11		
12		
13		
14		
15		
16		
17		
18		
19		
20		
21		
22		
23		
24		
25		
26		

**Table 14 RF Transmit Output Power Limits for ETSI Compliance (External Antenna)**

**Receiver Characteristics**  
 (T<sub>A</sub> = 25°C, V<sub>CC</sub> = 3.3V, f<sub>C</sub> = 2440 MHz)

Parameter	Test Conditions		Min	Typ	Max	Unit
Receiver sensitivity (1% PER)	HGM		-92	-97	-99	dBm
Saturation (maximum input level) (1% PER)	HGM			-13		dBm
Interference rejection	Desired signal at -82 dBm, 802.15.4 interferer	±5 MHz		47		dB
		±10 MHz		54		dB
		±20 MHz		57		dB

**Table 15 Receiver RF Characteristics**

For additional details regarding the electrical specifications, see the CC2530 and CC2591 datasheets on the TI website.

## SOLDERING RECOMMENDATIONS

### Recommended Reflow Profile for Lead Free Solder

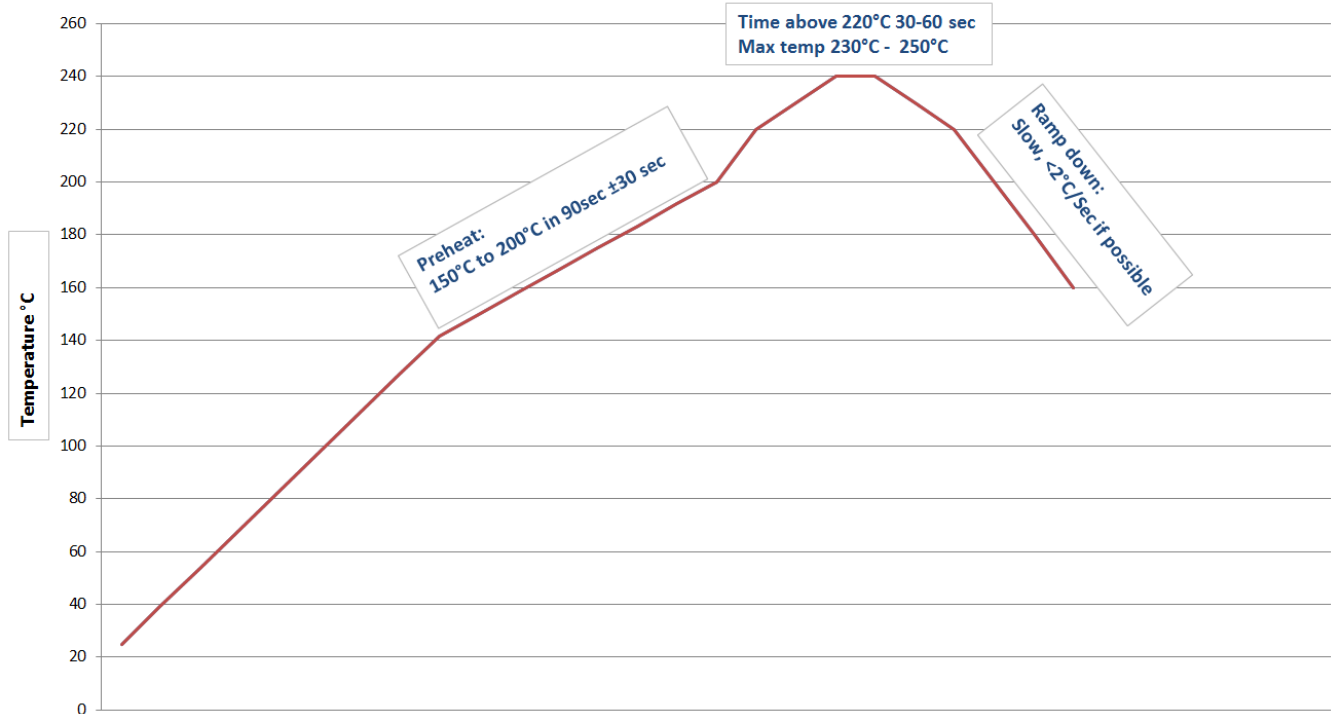

**Note: The quality of solder joints on the castellations ('half vias') where they contact the host board should meet the appropriate IPC Specification. See IPC-A-610-D Acceptability of Electronic Assemblies, section 8.2.4 Castellated Terminations."**

## CLEANING

In general, cleaning the populated modules is strongly discouraged. Residuals under the module cannot be easily removed with any cleaning process.

- Cleaning with water can lead to capillary effects where water is absorbed into the gap between the host board and the module. The combination of soldering flux residuals and encapsulated water could lead to short circuits between neighboring pads. Water could also damage any stickers or labels.
- Cleaning with alcohol or a similar organic solvent will likely flood soldering flux residuals into the RF shield, which is not accessible for post-washing inspection. The solvent could also damage any stickers or labels.
- Ultrasonic cleaning could damage the module permanently.

## OPTICAL INSPECTION

After soldering the Module to the host board, consider optical inspection to check the following:

- Proper alignment and centering of the module over the pads.
- Proper solder joints on all pads.
- Excessive solder or contacts to neighboring pads, or vias.

## REWORK

The module can be unsoldered from the host board if the Moisture Sensitivity Level (MSL) requirements are met as described in this datasheet.

**Never attempt a rework on the module itself, e.g. replacing individual components. Such actions will terminate warranty coverage.**

## SHIPPING, HANDLING, AND STORAGE

### Shipping

Bulk orders of the ProFLEX01-SOC modules are delivered in trays of 25.

### Handling

The ProFLEX01-SOC modules contain a highly sensitive electronic circuitry. Handling without proper ESD protection may destroy or damage the module permanently.

### Moisture Sensitivity Level (MSL)

Per J-STD-020, devices rated as MSL 4 and not stored in a sealed bag with desiccant pack should be baked prior to use.

After opening packaging, devices that will be subjected to reflow must be mounted within 72 hours of factory conditions (<30 °C and 60% RH) or stored at <10% RH.

Bake devices for 48 hours at 125 °C.

### Storage

Please use this product within 6 months after receipt. Any product used after 6 months of receipt needs to have solderability confirmed before use.

The product shall be stored without opening the packing under the ambient temperature from 5 to 35deg.C and humidity from 20 to 70%RH. (Packing materials, in particular, may be deformed at the temperatures above this range.)

Do not store in salty air or in an environment with a high concentration of corrosive gas, such as Cl<sub>2</sub>, H<sub>2</sub>S, NH<sub>3</sub>, SO<sub>2</sub>, or NO<sub>x</sub>.

Do not store in direct sunlight.

The product should not be subject to excessive mechanical shock.

## Repeating Reflow Soldering

Only a single reflow soldering process is encouraged for host boards.

## AGENCY STATEMENTS

### Agency Certifications

FCC ID: TFB-PROFLEX1SOC

IC ID: 5969A-PROFLEX1SOC

ETSI:

### Federal Communication Commission Interference Statement

This equipment has been tested and found to comply with the limits for a Class B digital device, pursuant to Part 15 of the FCC Rules. These limits are designed to provide reasonable protection against harmful interference in a residential installation. This equipment generates uses and can radiate radio frequency energy and, if not installed and used in accordance with the instructions, may cause harmful interference to radio communications. However, there is no guarantee that interference will not occur in a particular installation. If this equipment does cause harmful interference to radio or television reception, which can be determined by turning the equipment off and on, the user is encouraged to try to correct the interference by one of the following measures:

- Reorient or relocate the receiving antenna.
- Increase the separation between the equipment and receiver.
- Connect the equipment into an outlet on a circuit different from that to which the receiver is connected.
- Consult the dealer or an experienced radio/TV technician for help.

This device complies with Part 15 of the FCC Rules. Operation is subject to the following two conditions: (1) This device may not cause harmful interference, and (2) this device must accept any interference received, including interference that may cause undesired operation.

**FCC CAUTION: Any changes or modifications not expressly approved by the party responsible for compliance could void the user's authority to operate this equipment.**



## Industry Canada Statements

Operation is subject to the following two conditions: (1) this device may not cause interference, and (2) this device must accept any interference, including interference that may cause undesired operation of the device.

To reduce potential radio interference to other users, the antenna type and its gain should be so chosen that the equivalent isotropically radiated power (e.i.r.p.) is not more than that permitted for successful communication.

This device has been designed to operate with the antennas listed below, and having a maximum gain of 2.0 dB. Antennas not included in this list or having a gain greater than 2.0 dB are strictly prohibited for use with this device. The required antenna impedance is 50 ohms.

*LS Research 001-0001 2.4 GHz Dipole Antenna with Reverse Polarity SMA Connector and LS Research 080-0001 U.FL to Reverse Polarity SMA Bulkhead Cable (105mm in length)*

In addition to the antennas listed above, the ProFLEX01-SOC module has also been certified with an integrated PCB F-antenna.

Son fonctionnement est soumis aux deux conditions suivantes: (1) cet appareil ne peut pas provoquer d'interférences et (2) cet appareil doit accepter toute interférence, y compris les interférences qui peuvent causer un mauvais fonctionnement du dispositif.

Pour réduire le risque d'interférence aux autres utilisateurs, le type d'antenne et son gain doivent être choisis de façon que la puissance isotrope rayonnée équivalente (e.i.r.p) ne dépasse pas celle admise pour une communication réussie.

Cet appareil a été conçu pour fonctionner avec les antennes énumérées ci-dessous, et ayant un gain maximum de 2,0 dB. Antennes pas inclus dans cette liste ou ayant un gain supérieur à 2,0 dB sont strictement interdites pour une utilisation avec cet appareil. L'impédance d'antenne requise est de 50 ohms.

*LS Research 001-0001 2.4 GHz Antenne dipôle avec inversion de polarité Connecteur SMA et LS Research 080-0001 U.FL à inversion de polarité SMA traversée de câble (105 mm de longueur)*

En plus des antennes énumérées ci-dessus, le module ProFLEX01-SOC a également été certifié par un PCB integer F-antenne.

## OEM Responsibilities to comply with FCC and Industry Canada Regulations

The ProFLEX01-SOC Module has been certified for integration into products only by OEM integrators under the following conditions:

This device is granted for use in Mobile only configurations in which the antennas used for this transmitter must be installed to provide a separation distance of at least 20cm from all person and not be co-located with any other transmitters except in accordance with FCC and Industry Canada multi-transmitter product procedures.

As long as the two conditions above are met, further transmitter testing will not be required. However, the OEM integrator is still responsible for testing their end-product for any additional compliance requirements required with this module installed (for example, digital device emissions, PC peripheral requirements, etc.).

**IMPORTANT NOTE: In the event that these conditions cannot be met (for certain configurations or co-location with another transmitter), then the FCC and Industry Canada authorizations are no longer considered valid and the FCC ID and IC Certification Number cannot be used on the final product. In these circumstances, the OEM integrator will be responsible for re-evaluating the end product (including the transmitter) and obtaining a separate FCC and Industry Canada authorization.**

Le module ProFLEX01-SOC a été certifiée pour l'intégration dans les produits que par les intégrateurs OEM dans les conditions suivantes:

Ce dispositif est accordé pour une utilisation dans des configurations mobiles seule dans laquelle les antennes utilisées pour cet émetteur doit être installé pour fournir une distance de séparation d'au moins 20cm de toute personne et ne pas être co-localisés avec les autres émetteurs, sauf en conformité avec FCC et Industrie Canada, multi-émetteur procédures produit.

Tant que les deux conditions précitées sont réunies, les tests de transmetteurs supplémentaires ne seront pas tenus. Toutefois, l'intégrateur OEM est toujours responsable de tester leur produit final pour toutes les exigences de conformité supplémentaires requis avec ce module installé (par exemple, les émissions appareil numérique, les exigences de périphériques PC, etc.)

**NOTE IMPORTANTE: Dans le cas où ces conditions ne peuvent être satisfaites (pour certaines configurations ou de co-implantation avec un autre émetteur), puis la FCC et Industrie autorisations Canada ne sont plus considérés comme valides et l'ID de la FCC et IC numéro de certification ne peut pas être utilisé sur la produit final. Dans ces circonstances, l'intégrateur OEM sera chargé de réévaluer le produit final (y compris l'émetteur) et l'obtention d'un distincte de la FCC et Industrie Canada l'autorisation.**

## End Product Labelling

The ProFLEX01-SOC Module is labeled with its own FCC ID and IC Certification Number. If the FCC ID and IC Certification Number are not visible when the module is installed inside another device, then the outside of the device into which the module is installed must also display a label referring to the enclosed module. In that case, the final end product must be labeled in a visible area with the following:

**“Contains Transmitter Module FCC ID: TFB-PROFLEX1SOC”**

**“Contains Transmitter Module IC: 5969A-PROFLEX1SOC”**

or

**“Contains FCC ID: TFB-PROFLEX1SOC”**

**“Contains IC: 5969A-PROFLEX1SOC”**

The OEM of the ProFLEX01-SOC Module must only use the approved antenna(s) listed above, which have been certified with this module.

The OEM integrator has to be aware not to provide information to the end user regarding how to install or remove this RF module or change RF related parameters in the user manual of the end product.

**The user manual for the end product must include the following information in a prominent location:**

This device is granted for use in Mobile only configurations in which the antennas used for this transmitter must be installed to provide a separation distance of at least 20cm from all person and not be co-located with any other transmitters except in accordance with FCC and Industry Canada multi-transmitter product procedures.

Le ProFLEX01-SOC Module est étiqueté avec sa propre ID de la FCC et IC numéro de certification. Si l'ID de la FCC et IC numéro de certification ne sont pas visibles lorsque le module est installé à l'intérieur d'un autre appareil, puis l'extérieur de l'appareil dans lequel le module est installé doit également afficher une étiquette mentionnant le module ci-joint. Dans ce cas, le produit final doivent être étiquetés dans un endroit visible de ce qui suit:

**Module émetteur Contient FCC ID: TFB-PROFLEX1SOC**

**Module émetteur Contient IC: 5969A-PROFLEX1SOC**

ou

**Contient FCC ID: TFB-PROFLEX1SOC**

**Contient IC: 5969A-PROFLEX1SOC**

Le constructeur d'équipements de l'ProFLEX01-SOC module ne doit utiliser l'antenne approuvée (s) ci-dessus, qui ont été certifiés avec ce module.

L'intégrateur OEM doit être conscient de ne pas fournir des informations à l'utilisateur final quant à la façon d'installer ou de supprimer ce module RF ou RF changer les paramètres liés au mode d'emploi du produit final.

**Le manuel d'utilisation pour le produit final doit comporter les informations suivantes dans un endroit bien en vue:**

Ce dispositif est accordé pour une utilisation dans des configurations mobiles seule dans laquelle les antennes utilisées pour cet émetteur doit être installé pour fournir une distance de séparation d'au moins 20cm de toute personne et ne pas être co-localisés avec les autres émetteurs, sauf en conformité avec FCC et Industrie Canada, multi-émetteur procédures produit.

**MECHANICAL DATA**

**PCB Footprint**

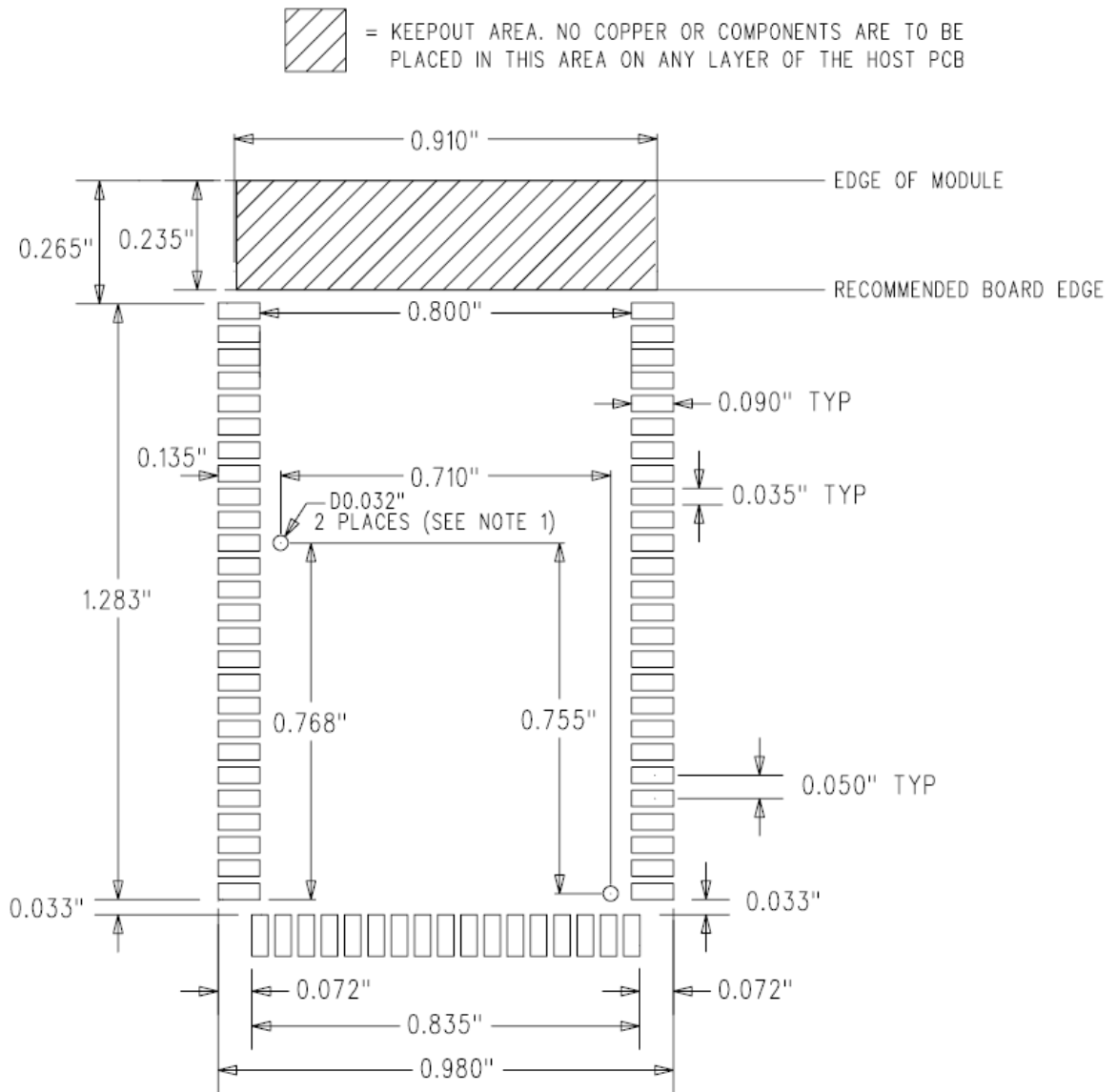

Notes:

- 1) Optional alignment holes are for use with fixture placement and hand soldering operations.
- 2) See <http://wiki.lsr.com> for additional information.

**Figure 7 PCB footprint**

**General Module Dimensions**

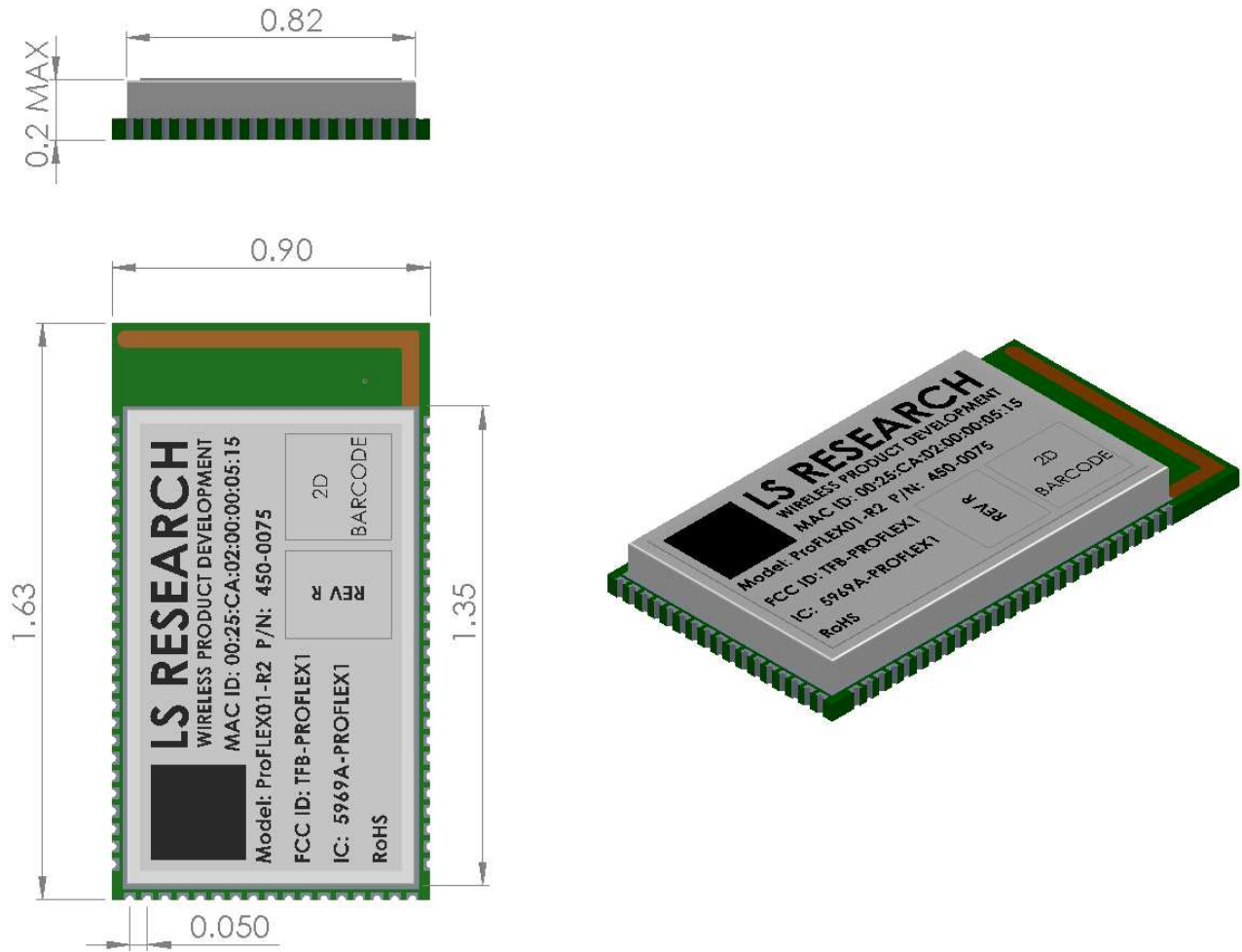

**Figure 8 Basic dimensions**

**COMPATIBILITY**

To maintain compatibility with other ModFLEX™ family transceiver modules it is important to use the module pins in your application as they are designated in Figure 9. Since the available GPIO and peripherals vary per micro, not all pins may be populated.

All attempts are made to lay out modules starting with the lowest number in the peripheral (ADC, TMR/PWM, GPIO) series. For example if there are only two ADC's available they will be brought out to ADC1 and ADC2 (module pins 20 and 21).

ModFLEX™ Generic Module Footprint																												
GND	1																									69	GND	
GND	2																										68	GND
GND	3																										67	GND
NC	4																										66	NC
NC	5																										65	NC
NC	6																										64	NC
NC	7																										63	NC
NC	8																										62	NC
JTAG - TMS	9																										61	SPI - MOSI
JTAG - TDI	10																										60	SPI - MISO
JTAG - TCK	11																										59	SPI - SCK
JTAG - TDO	12																										58	SPI - SS
JTAG/PDI/JRST	13																										57	IIC - SDA
nReset	14																										56	IIC - SCL
Analog REF	15																										55	GPIO 16
Analog REF	16																										54	GPIO 15
CMP+	17																										53	GPIO 14
CMP-	18																										52	GPIO 13
CMPOUT	19																										51	GPIO 12
ADC1	20																										50	GPIO 11
ADC2	21																										49	GPIO 10
ADC3	22																										48	GPIO 9
ADC4	23																										47	GPIO 8
ADC5	24																										46	GPIO 7
ADC6	25																										45	GPIO 6
VCC - 3V3DC	26																										44	GND
		27	28	29	30	31	32	33	34	35	36	37	38	39	40	41	42	43										
		TMR/PWM 1	TMR/PWM 2	TMR/PWM 3	TMR/PWM 4	TMR/PWM 5	TMR/PWM 6	TMR/PWM 7	TMR/PWM 8	UART - TX	UART - RX	UART - CTS	UART - RTS	GPIO 1	GPIO 2	GPIO 3	GPIO 4	GPIO 5										

**Figure 9 ModFLEX™ Generic Module Footprint**

**MODULE REVISION HISTORY**

**Rev 1**

- Initial production release.

Part Number: 450-0035  
F Antenna Module



00:25:CA:07:XX:XX:XX = MAC ID  
2D Barcode Format is Data Matrix Standard  
XX:XX:XX:XX = unique portion of MAC ID that changes for each module

Part Number: 450-0044  
U.FL Module



00:25:CA:07:XX:XX:XX = MAC ID  
2D Barcode Format is Data Matrix Standard  
XX:XX:XX:XX = unique portion of MAC ID that changes for each module



## CONTACTING LS RESEARCH

<b>Headquarters</b>	LS Research, LLC W66 N220 Commerce Court Cedarburg, WI 53012-2636 USA Tel: 1(262) 375-4400 Fax: 1(262) 375-4248
<b>Website</b>	<a href="http://www.lsr.com">www.lsr.com</a>
<b>Wiki</b>	<a href="http://wiki.lsr.com">wiki.lsr.com</a>
<b>Technical Support</b>	<a href="http://forum.lsr.com">forum.lsr.com</a>
<b>Sales Contact</b>	<a href="mailto:sales@lsr.com">sales@lsr.com</a>

The information in this document is provided in connection with LS Research (hereafter referred to as “LSR”) products. No license, express or implied, by estoppel or otherwise, to any intellectual property right is granted by this document or in connection with the sale of LSR products. EXCEPT AS SET FORTH IN LSR’S TERMS AND CONDITIONS OF SALE LOCATED ON LSR’S WEB SITE, LSR ASSUMES NO LIABILITY WHATSOEVER AND DISCLAIMS ANY EXPRESS, IMPLIED OR STATUTORY WARRANTY RELATING TO ITS PRODUCTS INCLUDING, BUT NOT LIMITED TO, THE IMPLIED WARRANTY OF MERCHANTABILITY, FITNESS FOR A PARTICULAR PURPOSE, OR NON-INFRINGEMENT. IN NO EVENT SHALL LSR BE LIABLE FOR ANY DIRECT, INDIRECT, CONSEQUENTIAL, PUNITIVE, SPECIAL OR INCIDENTAL DAMAGES (INCLUDING, WITHOUT LIMITATION, DAMAGES FOR LOSS OF PROFITS, BUSINESS INTERRUPTION, OR LOSS OF INFORMATION) ARISING OUT OF THE USE OR INABILITY TO USE THIS DOCUMENT, EVEN IF LSR HAS BEEN ADVISED OF THE POSSIBILITY OF SUCH DAMAGES. LSR makes no representations or warranties with respect to the accuracy or completeness of the contents of this document and reserves the right to make changes to specifications and product descriptions at any time without notice. LSR does not make any commitment to update the information contained herein. Unless specifically provided otherwise, LSR products are not suitable for, and shall not be used in, automotive applications. LSR’s products are not intended, authorized, or warranted for use as components in applications intended to support or sustain life.

---

The information in this document is subject to change without notice.